

TRATTORI AGRICOLI



AGRIFULL®

TOSELLI s.p.a.

44100 FERRARA - Via Marconi, 37

1ª edizione
stampato n. 604. 51.011

C80.50

**Catalogo parti di ricambio
Catalogue des pièces détachées
Spare parts catalogue
Ersatzteilkatalog
Catálogo de piezas de repuesto**

Per una corretta interpretazione di questo catalogo vedere:
AVVERTENZE PER LA CONSULTAZIONE DEL CATALOGO (pag. 6)

Pour l'interprétation correcte de ce catalogue voyez:
REGLES POUR LA CONSULTATION DU CATALOGUE (page 7)

Um den Katalog genau auslegen zu können, siehe:
HINWEISE ZUM GEBRAUCH DES KATALOGS (Seite 8)

For proper interpretation see:
USE OF THE CATALOG (page 9)

Para la correcta lectura del catálogo véase:
CÓMO SE MANEJA EL CATÁLOGO (pàg. 10)

I dati contenuti in questo catalogo sono forniti a titolo indicativo. L'AGRIFULL potrà apportare in qualunque momento modifiche ai modelli descritti in questo catalogo, per ragioni di natura tecnica o commerciale. Per ulteriore informazione, il cliente è pregato di rivolgersi al più vicino organizzato AGRIFULL.

Les données de cette brochure sont fournies à titre indicatif et pourraient se révéler caduques à la suite de modifications apportées par le constructeur, à n'importe quel moment, pour des raisons techniques ou commerciales ainsi que pour satisfaire aux normes en vigueur dans les différents Pays. Pour toute information, nous prions le client de bien vouloir s'adresser au Concessionnaire AGRIFULL les plus proches.

The information contained in this brochure is intended to be of a general nature only. AGRIFULL Company may at any time and from time to time, for technical or other necessary reasons, modify any of the details or specifications of the product described in this brochure. To be sure of getting accurate, detailed and up-to-date information, an intending buyer should consult his nearest AGRIFULL dealer or distributor or branch.

Alle in diesem Prospekt enthaltenen Angaben sind Orientierungsdaten. Es können jedoch von AGRIFULL sowohl aus technischen und kaufmännischen Gründen als auch aus der Notwendigkeit heraus, geänderte gesetzliche Erfordernisse der verschiedenen Länder zu berücksichtigen, Änderungen eingeführt werden. Der Kunde ist gebeten, sich für weitere Information an Vertrags-händler oder AGRIFULL zu wenden.

Los datos contenidos en este catálogo se facilitan a título indicativo. AGRIFULL podrá introducir, en cualquier momento, por razones de naturaleza tanto técnica como comercial, modificaciones en los modelos descritos en este catálogo. Para mayor información, rogamos al cliente se dirija al Concessionario AGRIFULL más próximo.

Tutti i diritti di riproduzione sono riservati alla Soc. p. Az. AGRIFULL - TOSELLI/FERRARA

Tous droits réservés à la Soc. p. Az. AGRIFULL-TOSELLI/FERRARA

All rights reserved by Soc. p. Az. AGRIFULL-TOSELLI/FERRARA

Alle Urheberrechte sind von der AGRIFULL-TOSELLI Soc. p. Az. - FERRARA - vorbehalten

Reservados todos los derechos para Soc. p. Az. AGRIFULL-TOSELLI/FERRARA

Copyright by Soc. p. Az. AGRIFULL-TOSELLI/FERRARA

Printed in Italy

AGRIFULL — Centro Ricambi ed Accessori

Stampato 604.51.011

STUDIO D.E.Ca. LUGO

INDICE GENERALE	INDEX	VERZEICHNIS	CONTENTS	ÍNDICE GENERAL
<ul style="list-style-type: none"> — Norme per le ordinazioni pag. 5 — Avvertenze generali per la consultazione del catalogo » 6 — Elenco dei modelli . . . » 11 — Elenco delle varianti . . » 13 — Indice dei sottogruppi » 17/1 — Indice delle parti di ricambio » 19/1 	<ul style="list-style-type: none"> — Commande de pièces détachées page 5 — Règles générales pour la consultation du catalogue » 7 — Liste des modèles . . . » 11 — Liste des variantes . . . » 13 — Index des sousgroupes » 17/1 — Index des pièces détachées » 19/1 	<ul style="list-style-type: none"> — Anweisungen zur Bestellung Seite 5 — Hinweise zum Gebrauch des Katalogs . . » 8 — Liste der Modelle » 11 — Verzeichnis der varianten » 13 — Untergruppenverzeichnis » 17/1 — Ersatzteile Verzeichnis . » 19/1 	<ul style="list-style-type: none"> — Ordering parts page 5 — Use of the catalog . . . » 9 — Model list » 11 — Variations list » 13 — Subgroup index » 17/1 — Spare parts index . . . » 19/1 	<ul style="list-style-type: none"> — Pedidos de repuesto pág. 5 — Cómo se maneja el catálogo » 10 — Lista de modelos . . . » 11 — Lista de variantes . . . » 13 — Índice de subgrupos . . » 17/1 — Índice de piezas de repuesto » 19/1
PARTI DI RICAMBIO	PIECES DETACHEES	ERSATZTEILE	SPARE PARTS	PIEZAS DE REPUESTO
<ul style="list-style-type: none"> — Tavole — Elenchi delle parti di ricambio 	<ul style="list-style-type: none"> — Planches — Listes des pièces détachées 	<ul style="list-style-type: none"> — Bildtafeln — Ersatzteilliste 	<ul style="list-style-type: none"> — Plates — Spare parts list 	<ul style="list-style-type: none"> — Láminas — Listas de piezas de repuesto
MODIFICHE	MODIFICATIONS	ÄNDERUNGEN	MODIFICATIONS	MODIFICACIONES
<ul style="list-style-type: none"> — Tabelle pag. 1M 	<ul style="list-style-type: none"> — Tableaux page 1M 	<ul style="list-style-type: none"> — Tabellen Seite 1M 	<ul style="list-style-type: none"> — Tables page 1M 	<ul style="list-style-type: none"> — Tablas pág. 1M

NORME PER LE ORDINAZIONI

Le **ordinazioni di parti di ricambio** devono essere corredate dalle seguenti indicazioni:

- Tipo del trattore (1)
- Numero dell'autotelaio (2)
- Numero di ordinazione della parte che si richiede (*come indicato nelle tavole e negli elenchi parti di ricambio*), in base al quale vengono evase le ordinazioni.

	AGRIFULL
	TOSELLI s.p.a. FERRARA · ITALIA
TRATTRICE TIPO	<input type="text"/>
TELAIO N°	<input type="text"/>

COMMANDE DE PIECES DETACHEES

Les **commandes** doivent nous parvenir complètes des indications suivantes:

- Type du tracteur (1)
- Numéro du châssis (2)
- Numéro de commande de la pièce requise (*comme indiqué sur les planches et aux listes des pièces*), d'après lequel les commandes sont expédiées.

ANWEISUNGEN ZUR BESTELLUNG

Bei Bestellung bitten wir stets folgendes anzugeben:

- Typ des Schleppers (1)
- Fahrgestellnummer (2)
- Bestellnummer des gewünschten Ersatzteils (*lt. Bildtafeln u. Listen*), auf Grund derer die Lieferung erfolgt.

ORDERING PARTS

Orders for spare parts must include the following data:

- Tractor type (1)
- Chassis number (2)
- Part number of the ordered spare, as given on plates and lists, that will be used to fill the order.

PEDIDOS DE REPUESTOS

En todos los pedidos de piezas de repuesto tienen que consignarse los datos siguientes:

- modelo del tractor (1)
- matrícula del chasis (2)
- número de pedido de la pieza requerida *el que coincidirá con el reseñado en las listas de piezas de repuesto y las láminas*, en base al cual se evacúa el pedido.

AVVERTENZE GENERALI PER LA CONSULTAZIONE DEL CATALOGO

1 - Ricerca delle parti di ricambio

Per una corretta ricerca delle parti di ricambio illustrate ed elencate nel catalogo, è necessario:

- a) consultare l'«**Elenco dei modelli**» per individuare il **codice numerico del modello** che interessa;
- b) consultare l'«**Elenco delle varianti**» per individuare il **codice numerico della variante** che interessa;
- c) consultare le **tavole** e i relativi **elenchi delle parti di ricambio** del catalogo, come indicato ai successivi punti 2 e 3.

2 - Elenchi delle parti di ricambio

Elencano le parti di ricambio di ciascun sottogruppo, illustrate nelle tavole e le parti fornite come «Serie», ecc. in **ordine progressivo di n. di ordinazione**.

Per una più completa interpretazione delle **denominazioni** delle parti di ricambio è opportuno riferirsi alle illustrazioni delle tavole.

Indicazioni e abbreviazioni usate negli elenchi:

SGR. = sottogruppo N. = numero COMPL. = complessivo SP. = spessore S = parte sinistra (°) D = parte destra (°) ANT. = anteriore (°) POST. = posteriore (°) 1A, 2A ... = 1a, 2a, ... velocità	SUP. = superiore INF. = inferiore EST. = esterno INT. = interno LAT. = laterale CENTR. = centrale R.M. = retromarcia RAPP. = rapporto
--	--

CM = fornito a centimetri M = fornito a metri T = ved. «Tabella varie» S = esistenza di «Serie», ecc.	nella colonna «quant.»
--	---------------------------

3 - Tavole

Illustrano le parti di ricambio di ciascun sottogruppo.

Ogni tavola riporta (a destra) il **numero del sottogruppo** e l'eventuale numero di foglio, la **denominazione del sottogruppo** (al centro) e le **indicazioni di validità della tavola** (a sinistra, con i codici dei modelli di cui al precedente punto 1a).

Le parti di ricambio illustrate sono contraddistinte dal **numero di figura** con a fianco tutte le indicazioni (*modifiche, codice, ecc.*) sufficienti in generale per poter individuare le parti stesse direttamente sulle tavole.

Indicazioni e abbreviazioni usate nelle tavole:

F ...	= parte antemodifica	
D ...	= parte postmodifica	
1, 2, ecc.	= vedere apposita tabella oppure elenco	
A, B, ecc.	= delle parti di ricambio	

sx	= parte sinistra (°)	
dx	= parte destra (°)	
∅ ...	= diametro... mm	



= esistenza di «Serie», «Dotazioni», «Corredi», ecc.

Validità della tavola

con le indicazioni dei codici di cui al punto 1a

F ... → aut. n. **076204**
 significa che la tavola vale «fino» al trattore con autotelaio n. 076204, in conseguenza della modifica

D ... aut n. **076205** →
 significa che la tavola vale «dal» trattore con autotelaio n. 076205, in conseguenza della modifica

(°) rispetto alla direzione di marcia del trattore

4 - Tabelle «MODIFICHE»

Elencano tutte le **modifiche** apportate ai trattori durante il corso della produzione, le loro **applicazioni** (con una eventuale **illustrazione complessiva della modifica**, quando si ritiene necessario) e le **norme di ricambio**.

Indicazioni e abbreviazioni usate nelle tabelle modifiche:

colonna «**Modifica**»:

F ... = modifica n. ... (per le parti antemodifica)
 D ... = modifica n. ... (per le parti postmodifica)

attuazioni:

→ aut. n. ... = «fino» al trattore con autotelaio n. ...
 → mot. n. ... = «fino» al motore n. ...
 aut. n. ... → = «dal» trattore con autotelaio n. ...
 mot. n. ... → = «dal» motore n. ...
 IX 1970 = nel mese di settembre 1970

colonna «**SGR. interessati e Norme di ricambio**»:

10.2/2-10.2/3 = sottogruppi interessati alla modifica

REGLES GENERALES POUR LA CONSULTATION DU CATALOGUE

1 - Recherche des pièces détachées

Pour la recherche correcte des pièces de rechange illustrées et numérotées dans le catalogue, il faut:

- a) consulter la «**Liste des modèles**» (à la page 11) afin d'individuer le **code numérique du modèle** qui intéresse;
- b) consulter la «**Liste des variantes**» (à page 13) pour trouver le **code numérique de la variante** qui vous intéresse;
- c) consulter les **planches** et les **listes des pièces détachées** correspondantes du catalogue, comme indiqué aux points 2 et 3 suivants.

2 - Liste des pièces détachées

Elle comprennent les pièces de rechange de chaque sous-groupe figurant sur les planches et les pièces livrées comme «Jeux», etc., **en ordre progressif de n. de commande**.

Pour une interprétation plus correcte des **désignations** des pièces détachées, il est opportun de se reporter aux illustrations des planches.

Symboles et abréviations utilisés dans la liste (*dans la partie en italien seulement*):

SGR. = sousgroupe N. = numéro COMPL. = ensemble SP. = épaisseur S = pièce gauche (°) D = pièce droite (°) ANT. = avant (°) POST. = arrière (°) 1A, 2A ... = 1re, 2me, ... vitesses	SUP. = supérieur INF. = inférieur EST. = extérieur INT. = intérieur LAT. = latéral CENTR. = central R.M. = marche AR RAPP. = rapport
--	---

CM = livré par centimètres M = livré par mètres T = voir «Tableaux divers» S = existence de «Jeux», etc.	<i>dans la colonne «quant.»</i>
---	---

3 - Planches

Elles représentent les pièces détachées de chaque sous-groupe.

Chaque planche reporte (à droite), le **numéro du sous-groupe** et le numéro de feuille éventuel, la **désignation du sous-groupe** (au centre) et les **indications de validité de la planche** (à gauche, avec les codes des modèles dont au point 1a précédent).

Les pièces représentées sont repérées par le **n. de commande** accompagné de toutes les indications (*modifications, codes, etc.*) suffisant en général à repérer les pièces elles-mêmes directement sur les planches.

Symboles et abréviations utilisés sur les planches:

F ...	= pièces antérieure à la modification	
D ...	= pièce postérieure à la modification	
1, 2, etc., A, B, ecc.	= voir le tableau exprès ou bien la liste des pièces détachées.	

sx = pièce gauche (°)		= existence de «Jeux», «Dotations», etc.
dx = pièce droite (°)		
Ø ... = diamètre... mm		

Validité de la planche

avec les indications des codes dont au point 1a

F ... →	aut. n. 076204 veut dire que cette planche est valable «jusqu'au» tracteur avec châssis 076204, par suite de la modification
D ...	aut. n. 076205 → veut dire que cette planche est valable «à partir du» tracteur avec châssis 076205, par suite de la modification

(°) par rapport au sens de roulement du tracteur

4 - Tableaux «MODIFICATIONS»

Dans cette tableaux sont reportées toutes les **modifications** apportées aux tracteurs en cours de leur production, leur **applications** (avec une illustration générale de la modification, quand cela est nécessaire) ainsi que les **règles d'interchangeabilité**.

Symboles et abréviations utilisés dans les tableaux des modifications:

colonne «**Modifica**» (*modification*):

- F ... = modification n. ... (*pour les pièces anciennes*)
- D ... = modification n. ... (*pour les pièces actuelles*)

effectuations:

- aut. n. ... = «jusqu'au» tracteur avec châssis n. ...
- mot. n. ... = «jusqu'au» moteur n. ...
- aut. n. ... → = «à partir» du tracteur avec châssis n. ...
- mot. n. ... → = «à partir» du moteur n. ...
- IX 1970 = au mois de septembre 1970

colonne «**Sgr. Interessati e Norme di ricambio**»

(*Sgr. concernés et règles pour les remplacements*):

- 10.2/2-10.2/3 = sousgroupes concernés par la modification

HINWEISE ZUM GEBRAUCH DES KATALOGS

1 - Auffinden der Ersatzteile

Zum Auffinden der in vorliegendem Katalog aufgeführten und abgebildeten Ersatzteile ist notwendig:

- a) die «**Liste der Modelle**» nachzuschlagen, um die **Kennummer** des in Frage kommenden **Modells** festzustellen;
- b) das **verzeichnis der varianten** nachschlagen, um der **kodex der gewünschten varianten** zu erkennen;
- c) die **Bildtafeln** und entsprechenden **Ersatzteillisten** nachzuschlagen, wie in den folgenden Punkten 2 u. 3 angegeben.

2 - Ersatzteilliste

Die Listen führen die in den Bildtafeln abgebildeten Ersatzteile usw., geliefert werden **in laufender Bestellnummernfolge** an.

Zur besseren Verständigung der **Benennung** der einzelnen Ersatzteile, siehe Bildtafeln.

Erläuterungen und Abkürzungen auf der Ersatzteilliste

SGR. = Untergruppe N. = Nummer COMPL. = Zusammenbau SP. = Stärke S = links (°) D = rechts (°) ANT. = vorn (°) POST. = hinten (°) 1A, 2A ... = 1., 2., ... Gang	SUP. = oben INF. = unten EST. = aussen INT. = innen LAT. = seitlich CENTR. = Mitte R.M. = Rückwärtsgang RAPP. = Untersetzung
--	---

CM = vom laufenden Zentimeter erhältlich M = vom laufenden Meter erhältlich T = siehe «Verschiedenes» S = Vorhandensein von «Sätzen» usw.	in der Spalte «quant.» (Anzahl)
--	---------------------------------------

3 - Bildtafeln

Die Tafeln veranschaulichen die Ersatzteile jeder einzelnen Untergruppe.

Auf jeder Bildtafel ist folgendes angegeben: die **Untergruppennummer** (rechts) mit der eventuellen Seitennummer des Katalogblatts, die **Untergruppenbenennung** (in der Mitte), sowie die **Gültigkeit der Bildtafel** (links, mit den Kennnummern der Modelle wie in Punkt 1a).

Die abgebildeten Ersatzteile sind mit den **Bestellnummern** und sämtlichen Angaben versehen (**Änderungen, Kennnummern usw.**), die im allgemeinen ausreichen, die gewünschten Teile direkt auf den Bildtafeln zu ermitteln.

Erläuterungen und Abkürzungen auf den Bildtafeln:

F ...	= früherer Teil	
D ...	= gegenwärtiger Teil	
A3.01	= in Utgr. A3.01 abgebildeter Teil	
1, 2, usw.	= siehe spezielle Tabelle oder Ersatzteilliste.	
A, B, usw.		

sx = links (°)		= Lieferbarkeit von Teilen als «Satz», «Serie», «Ausrüstung» usw.
dx = rechts (°)		
Ø ... = mm Durchmesser		

Gültigkeit der Bildtafeln:

durch die im Punkt 1a angegebenen Kennnummern angeführt

F ... → aut. n. **076204**
 bedeutet: die Tafel gilt «bis» Schlepper mit Fahrgestell Nr. 076204, infolge der Änderung

D ... aut. n. **076205** →
 bedeutet: die Tafel gilt «ab» Schlepper mit Fahrgestell Nr. 076205, infolge der Änderung

(°) in bezug auf die Fahrtrichtung des Schleppers

4 - Tabellen «ÄNDERUNGEN»

In diesem Abschnitt sind sämtliche im Laufe der Produktion den Schleppen vorgenommene **Änderungen** sowie ihre **Einführung** (mit einer eventuellen, falls für notwendig gefundenen Gesamtabbildung der Änderung) und die **Ersatzanweisungen** aufgeführt.

Hinweise und Abkürzungen in der Tabelle Änderungen:

Spalte «Modifica» (Änderung)

F ... = Änderungsnummer ... (frühere Teile)
 D ... = Änderungsnummer ... (gegenwärtige Teile)

Einführung:

→ aut. n. ... = «bis» Schlepper mit Fahrgestell-Nr. ...
 → mot. n. ... = «bis» Motor-Nr. ...
 aut. n. ... → = «ab» Schlepper mit Fahrgestell-Nr. ...
 mot. n. ... → = «ab» Motor-Nr. ...
 IX 1970 = September 1970

Spalte «Sgr. interessati e Norme di ricambio»

(betreffende Untergruppen und Ersatzanweisung):

10.2/2-10.2/3 = die Änderung betreffende Untergruppen

USE OF THE CATALOG

1 - How to locate spares

To find the spares shown and listed in the catalog, proceed as follows:

- a) consult the «**Model list**» to find the **code number** of the **model** involved;
- b) consult the «**variations list**» to find the **code number of the variation** involved;
- c) consult the **spare parts list and the plates** of the catalog, as directed below in **2 and 3**.

2 - Spare parts list

Lists the spare parts, illustrated in the plates and the parts supplied as «Set», «Kit», etc. of each subgroup, according to the **progressive part number**.

Refer to plate illustrations for a complete interpretation of spare **description**.

Indications and abbreviations used in the list (*only in the Italian section*):

SGR. = subgroup N. = number COMPL. = assembly SP. = thickness S = left (°) D = right (°) ANT. = front (°) POST. = rear (°) 1A, 2A ... = 1st, 2nd, ... gear		SUP. = upper INF. = lower EST. = outer INT. = inner LAT. = side CENTR. = center R.M. = reverse RAPP. = ratio
--	--	---

CM = supplied to the centimeter. M = supplied to the meter T = see «Miscellanea» S = some parts are supplied as «Set», «Kit», etc.		column «quant.»
---	--	--------------------

3 - Plates

Illustrations show the spare parts of each subgroup.

Below each plate there is the **Sgr. No.** (*right*) and sheet number, if any, the **Sgr. title** (*center*) and **plate applicability** (*left, by codes - see para, 1a*).

The spare parts illustrated are identified by respective **part numbers** together with other indications (*modifications, codes, etc.*) generality sufficient for direct location of parts on plate.

Indications and abbreviations used in the plates:

F ...	= ante-modification 951 part	
D ...	= post-modification 951 part	
1, 2, etc.,	= see the proper table or spare parts list	
A, B, etc.		

sx = left		= some parts are supplied as «Set», «Kit», etc.
dx = right (°)		
∅ ... = ... mm dia.		

Plate applicability

by the specific indications of code as referred in para 1a

F ... → aut. n. 076204

means: consequently to modification the plate is valid up to tractor with chassis No. 076204

D ... aut. n. 076205 →

means: consequently to modification the plate is valid from tractor with chassis No. 076205

(°) *determined by facing in the same direction as the driver*

4 - «MODIFICATIONS» tables

List all the **modifications** introduced on tractors during production, their **applicability** (*when necessary, show also a complete illustration of the modification as a whole*) and the **directions for replacement**.

Indications and abbreviations used in modification tables:

column «**Modifica**» (*modification*):

F ... = modification No. ... (*for the A.M. parts*)
 D ... = modifications No. ... (*for the P.M. parts*)

effectiveness:

→ aut. n. ... = up to tractor with chassis No. ...
 → mot. n. ... = up to engine No. ...
 aut. n. ... → = from tractor with chassis No. ...
 mot. n. ... → = from engine No. ...
 IX 1970 = introduced in september 1970

column «**Sgr. interessati e Norme di ricambio**» (*Sgr. involved and directions for replacement*):

10.2/2-10.2/3 = subgroups involved in the modification

CÓMO SE MANEJA EL CATÁLOGO

1 - Cómo se buscan las piezas de repuesto

Para buscar las piezas de repuesto reseñadas en el catálogo, hay que:

- a) conocer el número de código del modelo que interesa, el que figura en la «Lista de modelos»;
- b) consúltese la «Lista de variantes» para conocer el código de la variante que interesa;
- c) consultar la lista de piezas de repuesto y las láminas, atendiendo a cuanto se explica en los puntos 2 y 3.

2 - Lista de piezas de repuesto

Comprende las piezas de repuesto de cada subgrupo ilustradas en las láminas y las piezas incluidas en «Juegos», etc., y reseñadas según el orden progresivo del número de pedido.

Para comprender mejor las denominaciones de las piezas de repuesto es oportuno mirar las ilustraciones de las láminas.

Notaciones y abreviaturas usadas en la lista en lengua italiana:

<p>SGR. = subgrupo N. = número COMPL. = conjunto SP = espesor, grueso S = parte izquierda (°) D = parte derecha (°) ANT. = anterior (°) POST. = posterior (°) 1A, 2A ... = 1a, 2a, ... velocidades</p>		<p>SUP. = superior INF. = inferior EST. = exterior INT. = interior LAT. = lateral CENTR. = central R.M. = marcha atrás RAPP. = reducción</p>
--	--	---

<p>CM = se suministra por centímetros M = se suministra por metros T = véase «Tablas» S = existencia de «Juegos», etc.</p>	<p>en la columna «quant.» (= cantidades)</p>
---	--

3 - Láminas

Representan las piezas de recambio de cada subgrupo.

Al pie de cada hoja, tenemos: en la parte derecha, el número del subgrupo y el número de la hoja (eventual); en el centro, la denominación del subgrupo, y a la izquierda las indicaciones de validez de la lámina y los códigos de los modelos a que se alude en el punto 1a.

Cada pieza de recambio representada lleva el número de pedido acompañado de todas las indicaciones (modificaciones, códigos, etc.) que generalmente son suficientes para reconocer las mismas piezas en la lámina.

Notaciones y abreviaturas usadas en las láminas:

F ...	= pieza anterior a la modificación	
D ...	= pieza posterior a la modificación	
1, 2, etc.,	= véase la tabla especial, o bien la lista	
A, B, etc.	= de piezas de repuesto	

sx = parte izquierda (°)		= de algunas piezas se suministran «Juegos», etc.
dx = parte derecha (°)		
∅ ... = diámetro en mm		

Validez de la lámina

con las notaciones de los códigos citados en punto 1a.

F ... → aut. n. 076204
 significa que la lámina es válida «hasta» el tractor con chasis núm. 076204, por efecto de la modificación

D ... aut. n. 076205 →
 significa que la lámina es válida «a partir del» tractor con chasis núm. 076205, por efecto de la modificación

(°) respecto de la dirección de la marcha del tractor

4 - Tablas «MODIFICACIONES»

Comprenden todas las modificaciones habidas en los tractores durante su fabricación, cómo se incorporaron (y cuando se estime bien, la ilustración general de la modificación) y las normas para los recambios.

Notaciones y abreviaturas usadas en las tablas de modificaciones:

columna «Modifica» (= modificaciones):

F ... = modificación núm. ... (para las piezas antiguas)

D ... = modificación núm. ... (para las piezas nuevas)

incorporación:

→ aut. n. ... = «hasta» el tractor con chasis núm. ...

→ mot. n. ... = «hasta» el motor con núm. ...

aut. n. ... → = «a partir» del tractor con chasis núm. ...

mot. n. ... → = «a partir» del motor con núm. ...

IX 1970 = en el mes de septiembre 1970

columna «Sgr. interessati e Norme di ricambio» (= subgrupos afectados por la modificación y normas para los recambios):

10.2/2-10.2/3 = subgrupos afectados por la modificación

ELENCO DEI MODELLIListe des modèles
Liste der ModelleModel list
Lista de modelos

Modèle Modell	Modello	Model Modelo	Châssis Fahrgestell	Telaio	Chassis Chasis	Moteur Motor	Motore	Engine Motor	Code Kennummer	Codice	Code Código
	C80.50									01	
	C80.50 LARGO									02	
	C80.50 COMPATTO									03	

ELENCO DELLE VARIANTI

Liste des variantes
Liste der varianten

Variations list
Lista de variantes

Codice Code Kennumer Code Código	V A R I A N T E	Variante Varianten	Variation Variante
	Silenziatore verticale (03)	Silencieux vertical Senkrechter Schalldämpfer	Silencerr, vertical Silenciador vertical
	Radiatore a 3 file in rame	Radiateur à 3 rangées en cuivre Dreireihen-Kühler aus Kupfer	Radiator, 3 deep copper Radiador de 3 hileras de cobre
171	Radiatore c/alette in rame (03)	Radiateur avec ailettes en cuivre Kühler mit Kupferrippen	Radiator, copper fin Radiador con aletas de cobre
	Zavorre anteriori e supporto	Lest avant et support Frontballast und Halter	Front ballast and support Lastre anterior y soporte
	Suola 300 mm (02)	Tuile 300 mm Sohle 300 mm	Track shoe, 300 mm Zepata de 300 mm
	Catenaria (suole 200 mm) (03)	Chenille (Tuiles 200 mm) Raupenkette (Sohle 200 mm)	Track chain (200 mm shoe) Cadena (Zapatas de 200 mm)
	Suole 300 mm asimmetriche	Tuiles 300 mm asymétriques Asymmetrische Sohle 300 mm	Track shoe, 300 mm, asymmetric Zapatas de 300 mm, asimétricas
	Soprasuole 250 mm asimmetriche	Patins de route 250 mm asymétriques Asymmetrische Übersohle 250 mm	Tread plates, 250 mm asymmetric Patines de 250 mm, asimétricos
	Soprasuole 300 mm (02)	Patins de route 300 mm Übersohle 300 mm	Tread plates, 300 mm Patines de 300 mm
	Prefiltro aria «Iraq»	Prefiltre air «Iraq» Vorreiniger «Iraq»	Pre-filter «Iraq» Prefiltro de aire «Iraq»

Codice Code Kennumer	V A R I A N T E Code Código	Variante Varianten	Variation Variante
	Soprasuole 200 mm	Patins de route 200 mm Übersohle 200 mm	Tread plates, 200 mm Patines de 200 mm
	Soprasuole 300 mm asimmetriche	Patins de route, 300 mm asymétriques Asymmetrische Übersohle 300 mm	Tread plates, 300 mm asymmetric Patines de 300 mm, asimétricos
	Apparecchi illuminazione a lampade gialle	Dispositif d'illumination à lampes jaunes Beleuchtungsgeräte mit gelben lampen	Lighting devices, yellow Aparatos de alumbrado con lámparas amarillas
	Puleggia operatrice	Poulie de battage Nebenantriebe ohne riemenscheibe	Belt pulley Polea motriz
812	Presà pressione supplementare (comando a S.)	Prise supplémentaire de pression (commande à gauche) Doppelwirkende Zusatzsteuergerät (Link-gesteuert)	Additional power outlet unit (left-hand control) Grifo distribuidor auxiliar (mando a izquierda)
	Barra di traino	Barre d'attelage Ackerschiene	Draw bar Lanza de remolque
	Gancio di traino anteriore	Chape de refoulement AV Vorderer Abschleppha Ken	Pull Hook Enganche de remolque anterior
	Accumulatore 110A Marelli oppure 120A Scaini	Batterie d'acus 110A Marelli ou 120A Scaini Batterie Marelli 110A oder 120A Scaini	Battery 110A Marelli or 120A Scaini Batería de 110A Marelli; o bien de 120A Scaini
821	Sollevatore a martinetti	Relevage a cilindres ydrauliques Hydraulikzylinderkraftheber	Ydraulic cylinder lifter Elevador cilindros idraulicos

	INDICE DEI SOTTOGRUPPI	INDEX DES SOUSGROUPES	UNTERGRUPPEN- VERZEICHNIS	SUBGROUP INDEX	INDICE DE SUBGRUPOS
10.01/01	BASAMENTO E TESTA CILINDRI	BATI ET CULASSE	KURBELGEHAUSE UND ZYLINDERKOPF	CRANKCASE AND CYLINDER HEAD	BLOQUE DE CILINDROS Y CULATA
10.01/02	COPPA E COPERCHI BASAMENTO	CARTER D'HUILE ET COUVERCLES DE BATI	OELWANNE UND DECKEL DES KURBELGEHAUSES	OIL SUMP AND CRANKCASE COVERS	CARTER DE ACEITE Y TAPAS DEL BLOQUE
10.01/03	COPPA E COPERCHI BASAMENTO	CARTER D'HUILE ET COUVERCLES DE BATI	OELWANNE UND DECKEL DES KURBELGEHAUSES	OIL SUMP AND CRANKCASE COVERS	CARTER DE ACEITE Y TAPAS DEL BLOQUE
10.02/01	ALBERO E VOLANO MOTORE	VILEBREQUIN ET VOLANT MOTEUR	KURBELWELLE UND SCHWUNGRAD	CRANKSHAFT AND FLYWHEEL	CIGUENAL Y VOLANTE
10.02/02	BIELLE E STANTUFFI	BIELLES ET PISTONS	PLEUELSTANGEN UND KOLBEN	CONNECTING RODS AND PISTONS	BIELAS Y EMBOLOS
10.03/01	COMANDO DISTRIBUZIONE	COMMANDE DE DISTRIBUTION	STEUERUNGSANTRIEB	CAMSHAFT DRIVE	PINONES DE LA DISTRIBUCION
10.03/02	DISTRIBUZIONE	DISTRIBUTION	STEUERUNG	VALVE GEAR	DISTRIBUCION
10.05/01	LUBRIFICAZIONE	GRAISSAGE	SCHMIERUNG	LUBRIFICATION SYSTEM	ENGRASE
10.05/02	LUBRIFICAZIONE	GRAISSAGE	SCHMIERUNG	LUBRIFICATION SYSTEM	ENGRASE
10.05/03	POMPA OLIO	POMPE A HUILE	OELPUMPE	OIL PUMP	BOMBA DE ACEITE
10.06/01	ALIMENTAZIONE AD INIEZIONE C.A.V.	ALIMENTATION PAR INJECTION	EINSPRITZAUSTRUE-	FUEL INJECTION SYSTEM	ALIMENTATION E INYECCION
10.06/02	ALIMENTAZIONE AD INIEZIONE C.A.V.	ALIMENTATION PAR INJECTION	EINSPRITZAUSTRUE-	FUEL INJECTION SYSTEM	ALIMENTATION E INYECCION
10.06/03	COMANDO POMPA INIEZIONE C.A.V.	COMMANDE POMPE D'INJECTION	EINSPRITZPUMPENAN- TRIEB	INJECTION PUMP DRIVE	ARRASTRE DE LA BOMBA DE INYECCION
10.06/04	POMPA INIEZIONE C.A.V.	POMPE D'INJECTION	EINPRINTZPUMPE	INJECTION PUMP	BOMBA DE INYECCION

10.06/05	POMPA INIEZIONE C.A.V.	POMPE D'INJECTION	EINPRINTZPUMPE	INJECTION PUMP	BOMBA DE INYECCION
10.06/06	POMPA DI ALIMENTA- ZIONE	POMPE D'ALIMENTA- TION	KRAFTSTOFFPUMPE	FUEL PUMP	BOMBA DE ALIMENTA- CION
10.06/07	FILTRO COMBUSTIBILE	FILTRE A COMBUSTIBLE	KRAFTSTOFFFILTER	FUEL FILTER	FILTRO DE COMBUSTIBLE
10.06/08	FILTRO COMBUSTIBILE	FILTRE A COMBUSTIBLE	KRAFTSTOFFFILTER	FUEL FILTER	FILTRO DE COMBUSTIBLE
10.06/09	PORTAPOLVERIZZATORE	PORTE-INJECTEUR	DUESENHALTER	NOZZLE HOLDER	PORTAINJECTOR
10.06/10	PORTAPOLVERIZZATORE C.A.V.	PORTE-INJECTEUR	DUESENHALTER	NOZZLE HOLDER	PORTAINJECTOR
10.06/11	PORTAPOLVERIZZATORE OMAP	PORTE-INJECTEUR	DUESENHALTER	NOZZLE HOLDER	PORTAINJECTOR
10.07/01	RADIATORE	RADIATEUR	KUEHLER	RADIATOR	RADIADOR
10.07/02	POMPA ACQUA E TUBAZIONI	POMPE ET CANALISATIONS D'EAU	WASSERPUMPE UND LEITUNGEN	WATER PUMP AND LINES	BOMBA DE AGUA Y TUBERIAS
10.07/03	POMPA ACQUA E TUBAZIONI	POMPE ET CANALISATIONS D'EAU	WASSERPUMPE UND LEITUNGEN	WATER PUMP AND LINES	BOMBA DE AGUA Y TUBERIAS
10.07/04	POMPA ACQUA	POMPE A EAU	WASSERPUMPE	WATER PUMP	BOMBA DE AGUA
10.07/05	VENTILATORE E SUO COMANDO	VENTILATEUR ET SA COMMANDE	LUEFTER UND LUEFTERANTRIEB	FAN AND FAN DRIVE	VENTILADOR Y SU MANDO
10.07/06	VENTILATORE E SUO COMANDO	VENTILATEUR ET SA COMMANDE	LUEFTER UND LUEFTERANTRIEB	FAN AND FAN DRIVE	VENTILADOR Y SU MANDO
10.08/01	DISPOSITIVI PER AV- VIAMENTO BASSA TEMP.	DISP.POUR DEMARRAGE PAR BASSE TEMP.	ANLASSVORRICHTUNG BEITIEFER TEMPER.	LOW TEMPERATURE STARTING AIDS	DISP.PARA EL ARRAN- QUE EN TIEMPO FRIO
10.08/02	CONDOTTI ASPIRAZIONE E SCARICO	TUBULURES D'ASMIS- SION ET D'ECHAP.	SAUG-UNG AUSPUFF- KRUEMMER	INTAKE AND EXHAUST MANIFOLDS	COLECTORES DE ADMISION Y ESCAPE
10.08/03	TUBAZIONE DI SCARICO.	CANALISATION D'ECHAPPEMENT	AUSPUFFLEITUNG	AXHAUST PIPE	TUBERIA DE ESCAPE

10.08/04	TUBAZIONE DI SCARICO	CANALISATION D'ECHAPPEMENT	AUSPUFFLEITUNG	AXHAUST PIPE	TUBERIA DE ESCAPE
20.05/01	FRIZIONE	EMBRAYAGE	KUPPLUNG	CLUTCH	EMBRAGUE
30.01/01	SCATOLA CAMBIO	CARTER DE BOITE V	GETRIEBEGEHAEUSE	TRANSMISSION CASE	CAJA ENGRANAJE
30.01/02	SCATOLA CAMBIO - 820 -	CARTER DE BOITE V	GETRIEBEGEHAEUSE	TRANSMISSION CASE	CAJA ENGRANAJE
30.02/01	CAMBIO VELOCITA°	BOITE DE VITESSES	WECHSELGETRIEBE	TRANSMISSION	CAMBIO DE VELOCIDADES
30.04/01	RIDUTTORE CAMBIO	REDUCTEUR DE B.V.	UNTERSETZUNGSGE- TRIEBE	REDUCTION GEAR	REENVIO REDUCTOR
30.05/01	DIFFERENZIALE POSTERIORE	DIFFERENTIEL AR	AUSGLEICHGETRIEBE- HINTEN	REAR DIFFERENTIAL	DIFERENCIAL POSTERIOR
30.06/01	PRESA DI FORZA	PRISE DE FORCE	ZAPFWELLE	POWER TAKE-OFF	TOMA DE FUERZA
30.06/02	PULEGGIA OPERATRICE	POULIE DE BATTAGE	RIEMENSCHLEIBE FUR NEBENANTRIEBE	BELT PULLEY	POLEA MOTRIZ
40.04/01	PONTE POSTERIORE	PONT ARRIERE	HINTERACHSE	REAR AXLE	PUENTE POSTERIOR
40.07/01	RIDUTTORI LATERALI POSTERIORI	REDUCTEURS LATERAUX AR	WEUEN DER HINTEREN ENDANTRIEBE	REAR SIDE FINAL DRIVE	REDUCTORES LATERA- LES POSTERIORE
40.07/02	RIDUTTORI LATERALI POSTERIORI	REDUCTEURS LATERAUX AR	WEUEN DER HINTEREN ENDANTRIEBE	REAR SIDE FINAL DRIVE	REDUCTORES LATERA- LES POSTERIORE
50.01/01	SOSPENSIONE ANTERIORE	SUSPENSION AV	VORDERRADAUFHAEN- GUNG	FRONT SUSPENSION	SUSPENSION ANTERIOR
50.02/01	SUPPORTO ANTERIORE	BERCEAU ESSIEU	ACHSCAGERBOCK	AXLE BRACKET	CABALLETE PEJE
50.03/01	CORPO CARRELLO CINGOLO	CHASSIS DE CHARIOT DE CHENILLE	LAUFWERKRAHMEN	TRACK FRAME BODY	ARMAZON DE CADENA
50.03/02	SOSPENSIONE POSTERIORE	SUSPENSION AR	HINTERRADAUFHAEN- GUNG	REAR SUSPENSION	SUSPENSION POSTERIOR
50.04/01	FRENI	FREINS	BREMSEN	BRAKES	FRENOS

50.04/02	FRIZIONI DI STERZO	EMBRAYAGES DE DIRECTION	LENKKUPPLUNG	STEERING CLUTCHES	EMBRAGUES DE DIRECCION
50.05/01	RUOTA MOTRICE	BARBOTIN MOTEUR	TREIBRAD	DRIVE SPROCKET	RUEDA MOTRIZ
50.05/02	TENDICINGOLO	ROUE TENDEUSE	LEITRAD	IDLER WHEEL	RUEDA MOTRIZ
50.05/03	TENDICINGOLO	ROUE TENDEUSE	LEITRAD	IDLER WHEEL	RUEDA MOTRIZ
50.05/04	RULLO CARRELLO CINGOLO	GALET PORTEUR DE CHENILLE	LAUFROLLE DER RAUPENKETTE	TRACK ROLLER	RODILLO DE APOYO DE LA CADENA
50.06/01	CINGOLO	CHENILLE	RAUPENKETTE	TRACK	CADENA
60.01/01	COMANDO DISINNESTO FRIZIONI DI STERZO	COMM.DES EMBRAYAG. DE DIRECTION	AUSRUECKVORRICHT. DER LENKKUPPLUNG	STEERING CLUTCHES RELEASE CONTROL	MANDO DE EMBRAGUES DE DIRECCION
60.04/01	COMANDO CAMBIO	COMMANDES DE BOITE DE VITESSE	GETRIEBESCHALTUNG	GEAR SHIFT CONTROL	VARILLAJE DEL CAMBIO DE VELOCID.
60.04/02	COMANDO CAMBIO	COMMANDES DE BOITE DE VITESSE	GETRIEBESCHALTUNG	GEAR SHIFT CONTROL	VARILLAJE DEL CAMBIO DE VELOCID.
60.05/01	COMANDO DISINNESTO FRIZIONE	COMMANDE DE DEBRAYAGE	KUPPLUNGSBETAETIGUNG	CLUTCH RELEASE CONTROL	SISTEMA DE EMBRAGUE
60.06/01	COMANDO A MANO FRENI	COMMANDE DE FREINS A MAIN	HANDBREMSBETAETIGUNG	BRAKE HAND CONTROL	FRENO DE MANO
60.07/01	COMANDI ACCELERATORE	COMMANDES D'ACCELERATEUR	GASREGULIERUNG	ACCELERATOR CONTROL LINKAGE	MANDOL DEL ACELERADOR
60.08/01	COMANDO PRESA DI FORZA	COMMANDE DE PRISE DE FORCE	ANTRIEB DER ZAPFWELLE	PTO CONTROL	MANDO DE TOMA DE FUERZA
70.02/01	COFANO	CAPOT	HAUBE	HOOD	CAPOT
70.03/01	SUPPORTI	SUPPORT	LAGER	SUPPORT	SUPORTE
70.04/01	CRUSCOTTO	TABLIER	STIRNWAND	DASH/PANEL	TABLERO
70.05/01	SEDILE CONDUTTORE	SIEGE DE CONDUCTEUR	FAHRERSITZ	DRIVER S SEAT	BUTACA DE CONDUCTOR

70.05/02	SEDILE CONDUTTORE	SIEGE DE CONDUCTEUR	FAHRERSITZ	DRIVER S SEAT	BUTACA DE CONDUCTOR
70.06/01	PARAFANGHI E PEDANE	AILES ET MARCHE- PIEDS	KOTFLUEGEL UND TRITTBRETT	MUDGUARDS AND FOOTBOARDS	GUARDABARROS Y ESTRIBOS
70.06/02	PARAFANGHI E PEDANE	AILES ET MARCHE- PIEDS	KOTFLUEGEL UND TRITTBRETT	MUDGUARDS AND FOOTBOARDS	GUARDABARROS Y ESTRIBOS
70.07/01	RIPARI CINGOLI	PROTECTIONS DE CHENILLES	SCHUTZBLECHE DER RAUPENKETTE	TRACK COVERS	BLINDAJE DE CADENAS
80.01/01	SERBATOIO	RESERVOIR	BEHAELTER	TANK	DEPOSITO
80.01/02	FILTRO ARIA-BAGNO D'OLIO	FILTRE AIR A BAIN D'HUILE	OELBADLUFTFILTER	OIL BATH AIR CLEANER	FILTRO AIRE EN BANO ACEITE
80.01/03	PREFILTRO ARIA - IRAQ -	PREFILTRE A AIR	VORREINIGER	PRE-FILTER	PREFILTRO DE AIRE
80.04/01	IMPIANTO ELETTRICO	INSTALL ELECTRIQUE	ELEKTROANLAGE	ELECTRIC SYSTEM	SISTEMA ELECTRICO
80.04/02	ALTERNATORE	ALTERNATEUR	DREHSTROMLICHTMA- CHINE	ALTERNATOR	ALTERNADOR
80.04/03	ALTERNATORE	ALTERNATEUR	DREHSTROMLICHTMA- CHINE	ALTERNATOR	ALTERNADOR
80.04/04	MOTORINO D'AVVIAMENTO MARELLI	DEMARREUR	ANLASSER	STARTER MOTOR	MOTOR DE ARRANQUE
80.05/01	IMPIANTO ELETTRICO ANTERIORE	INSTALLATION ELECTRIQUE AVANT	VORDERELEKRO- ANLAGE	FRONT ELECTRIC SYSTEM	SISTEMA ELECTRICO DELANTERO
80.05/02	IMPIANTO ELETTRICO POSTERIORE	INSTALLATION ELECTRIQUE ARRIERE	ELEKTROANLAGE- HINTEN	REAR ELECTRIC SYSTEM	SISTEMA ELECTRICO POSTERIOR
80.05/03	PROIETTORI	PROJECTEURS	SCHEINWERFER	SPOT LAMPS	PROYECTORES
90.01/01	SOLLEVATORE IDRAULICO	REVELAGE HYDRAULIQUE	HYDRAULISCHER KRAFTHEB.	HYDRAULIC LIFTER	ELEVADOR HIDRAULICO
90.01/02	COMANDO POMPA	COMMANDE DE LA POMPE	PUMPENANTRIEB	PUMP DRIVE	ACCIONAM. BOMBA

90.01/03	POMPA SOLLEVATORE	POMPE DU RELEVAGE	KRAFHEBER PUMPE	LIFTER PUMP	BOMBA DE ELEVADOR
90.01/04	CORPO SOLLEVATORE	CARTER DU RELEVAGE	KRAFTHEBERGEHAUSE	LIFTER BODY	CUERPO DEL ELEVADOR
90.01/05	STANTUFFO E BRACCI SOLLEVATORE	PISTON ET BRAS DE RELEVAGE	KOLBEN UND ARME DES KRAFTHEBERS	LIFTER RAM AND LINKS	EMBOLO Y BRAZOS DEL ELEVADOR
90.01/06	DISTRIBUTORE	DISTRIBUTEUR	STEUERGERAET	DISTRIBUTOR VALVE	VALVULA DISTRIBUIDORA
90.01/07	COMANDI INTERNI SOLLEVATORE	COMMANDES INTERIEU- RES DE RELEVAGE	INNERE BETAETIGUNG DES KRAFTHEBERS	LIFTER INNER CONTROLS	MANDOS INTERIORES DEL ELEVADOR
90.01/08	COMANDI ESTERNI	COMMANDES EXTERIEURES	AUSSERE BETAETIGUNG	OUTER CONTROLS	MANDOS ESTERIORES
90.01/09	COMANDI ESTERNI	COMMANDES EXTERIEURES	AUSSERE BETAETIGUNG	OUTER CONTROLS	MANDOS ESTERIORES
90.02/01	SOLLEVATORE A MARTINETTI - 821 -	RELEVAGE A CILINDRES YDRAULIQUES	HYDRAULIKZILINDER- KRAFTHEBER	YDRAULIC CYLINDER LIFTER	ELEVADOR CILINDROS IDRAULICOS
90.02/02	COMANDO POMPA - 821 -	COMMANDE DE LA POMPE	PUMPENANTRIEB	PUMP DRIVE	ACCIONAM. BOMBA
90.02/03	POMPA SOLLEVATORE - 821-	POMPE DE RELEVAGE	KRAFTHEBER PUMPE	LIFTER PUMP	BOMBA DE ELEVADOR
90.02/04	SOLLEVATORE A MARTINETTI - 821 -	RELEVAGE A CILINDRES YDRAULIQUES	HYDRAULIKZILINDER- KRAFTHEBER	YDRAULIC CYLINDER LIFTER	ELEVADOR CILINDROS IDRAULICOS
90.02/05	BRACCI SOLLEVATORE - 821 -	BRAS DE RELEVAGE	HUBARME	LIFTER LINKS	BRAZOS DEL ELEVADOR
90.02/06	MARTINETTO - 821 -	CYLINDRE A PISTON	KOLBENZYLINDER	CYLINDER	CILINDRO PISTON
90.02/07	DISTRIBUTORE - 821 -	DISTRIBUTEUR	STEUERGERAET	DISTRIBUTOR VALVE	VALVULA DISTRIBUIDORA
90.02/08	COMANDI ESTERNI SOLLEVATORE - 821 -	COMMANDES EXTERIEU- RES DE RELEVAGES	AUSSERE BETAETIGUNG DES KRAFTHEBERS	LIFTER OUTER CONTROLS	MANDOS EXTERIORES DEL ELEVADOR
90.03/01	ATTACCO A 3 PUNTI	ATTELAGE TROIS PTS	DREIPUNKTKUPPLUNG	3-POINT LINKAGE	ACOPLAM. 3 PUNTOS

90.03/02	TIRANTE REGISTRABILE	TIRANT REGLABLE	VERSTELLB. HUBSTREBE	ADJUSTABLE TIEROD	MONTANTE REGULABLE
90.04/01	BARRA DI TRAINO	BARRE D'ATTELAGE	ZUGPENDEL	DRAWBAR	LANZA DE REMOLQUE
90.04/02	BARRA DI TRAINO	BARRE D'ATTELAGE	ZUGPENDEL	DRAWBAR	LANZA DE REMOLQUE
90.05/01	DISTRIBUTORE DOPPIO EFFETTO	DISTRIBÜTEUR A DOUBLE EFFET	DOPPELTWIRKENDEN STEVERSCHIEBER	DOUBLE EFFECT DISTRIBUTOR VALVE	DISTRIBUDOR DE DOBLE EFECTO
90.05/02	DISTRIBUTORE DOPPIO EFFETTO	DISTRIBUTEUR A DOUBLE EFFET	DOPPELTWIRKENDEN STEVERSCHIEBER	DOUBLE EFFECT DISTRIBUTOR VALVE	DISTRIBUDOR DE DOBLE EFECTO
91.01/01	CASSETTA PER ATTREZZI	COFFRE A OUTILS	KASTEN FUER WERKZEUGE	TOOL BOX	CAJA DE HERRAMIÉNTAS
91.01/02	DOTAZIONE ATTREZZI	OUTILLAGE	WERKZEUGAUSRÜSTNG	TOOLKIT	EQUIPO HERRAMIENTAS
91.01/03	SUPPORTO LEVA FRENO RIMORCHIO	SUPPORT DE LEVIER DE FREIN DE REM.	LAGER FÜR ANHANGERBREMSHEBEL	SUPP.FOR TRAILER BRAKE CONTROL LEV.	SOPORTE DE PALANCA DEL FRENO DE REM.

N. ORDINAZIONE	SGR	FIG	N. ORDINAZIONE	SGR	FIG	N. ORDINAZIONE	SGR	FIG	N. ORDINAZIONE	SGR	FIG
15480	60.06/01	10	556412	40.07/02	18	562135	30.06/02	15	565541	30.02/01	28
536435	60.04/02	18	557078	50.06/01	5	562136	30.06/02	15	565544	30.02/01	17
536570	40.07/01	8	557079	50.06/01	6	562137	30.06/02	15	565545	30.02/01	30
536572	40.07/01	13	557081	50.06/01	10	562139	30.06/02	27	565548	60.04/01	18
"	40.07/02	21	557084	50.06/01	11	562140	30.06/02	14	565617	20.05/01	3
538332	40.07/01	7	557155	50.06/01	3	562141	30.06/02	14	565620	20.05/01	14
"	40.07/02	4	557156	50.06/01	9	562142	30.06/02	14	565750	60.04/02	11
538333	40.07/01	5	557311	40.07/02	7	562143	30.06/02	14	565916	60.05/01	19
538335	40.07/01	18	557481	50.06/01	4	562144	30.06/02	14	566337	80.05/02	18
"	40.07/02	14	558435	50.06/01	4	562145	30.06/02	3	566339	80.05/02	20
538337	40.07/01	21	559627	50.04/01	3	562153	30.06/01	9	566340	80.05/02	19
"	40.07/02	17	559699	60.08/01	3	562187	50.04/01	12	566406	50.04/02	4
538338	40.07/01	19	559701	60.08/01	6	562480	50.02/01	15	566445	30.05/01	6
"	40.07/02	15	559917	90.04/02	7	562515	80.01/03	3	566454	30.05/01	5
538595	60.05/01	9	559930	90.01/04	5	562599	30.06/01	2	566461	30.05/01	1
539062	91.01/02	8	559948	90.01/06	9	562607	60.08/01	2	566478	60.01/01	8
539197	40.07/02	3	559950	90.01/06	31	562610	60.08/01	8	566479	60.01/01	27
539203	40.04/01	20	559952	90.01/06	1	562619	50.05/02	18	566480	50.04/02	7
539207	40.07/02	12	559955	90.01/07	9	562620	50.05/02	30	566514	30.05/01	2
539526	50.05/01	3	559958	90.01/04	3	562621	50.05/02	3	566519	50.04/02	10
539598	50.05/01	3	"	90.01/06	23	562631	50.05/02	32	566522	50.04/02	5
541053	60.07/01	9	559970	90.01/08	31	562659	30.05/01	3	566525	30.05/01	13
541727	40.07/01	4	559983	90.01/07	11	"	60.01/01	17	566559	90.01/08	30
543458	40.07/02	2	559994	90.01/04	11	562676	60.01/01	10	566576	90.01/07	13
547517	40.07/01	25	560057	90.01/01	20	562678	60.01/01	12	566594	90.01/08	10
"	40.07/02	22	560571	30.06/02	22	562830	50.02/01	17	566604	90.01/04	31
547545	60.01/01	26	560646	30.06/02	7	563051	30.02/01	20	566614	50.05/04	9
547546	60.01/01	18	561293	10.05/01	3	563126	60.06/01	14	566627	50.05/02	29
549537	91.01/02	14	561719	30.02/01	19	563438	60.04/01	8	566638	50.05/02	11
551061	60.07/01	8	561831	90.03/01	23	563453	60.04/01	1	566639	50.05/02	24
551919	40.04/01	17	561880	60.08/01	1	563454	60.04/01	6	566641	50.05/02	17
551982	40.07/01	20	"	90.01/08	34	563466	30.02/01	16	566642	50.05/02	23
"	40.07/02	16	"	90.05/01	2	563652	10.03/02	11	566665	50.01/01	30
553209	90.01/08	12	561887	60.07/01	7	564170	90.01/06	11	566675	60.01/01	11
553386	40.07/01	9	561991	30.02/01	2	564530	90.01/02	1	566864	90.01/08	29
553658	80.01/02	10	562126	30.06/02	28	"	90.02/02	1	567281	70.04/01	18
553659	80.01/02	11	562129	30.06/02	23	564603	40.04/01	14	567381	90.01/04	13
553662	80.01/02	13	562130	30.06/02	13	565531	30.04/01	9	567406	50.02/01	11
554215	60.06/01	13	562131	30.06/02	2	565533	30.04/01	5	"	90.02/05	4
554264	40.04/01	16	562132	30.06/02	9	565537	30.04/01	12	"	90.03/01	1
555486	91.01/02	16	562133	30.06/02	15	565538	30.04/01	4	"	90.04/01	16
556412	40.07/01	22	562134	30.06/02	15	565540	30.04/01	15	"	90.04/02	16

N. ORDINAZIONE	SGR	FIG	N. ORDINAZIONE	SGR	FIG	N. ORDINAZIONE	SGR	FIG	N. ORDINAZIONE	SGR	FIG
567437	50.04/01	23	570933	20.05/01	22	577567	60.08/01	4	583835	90.02/08	7
567633	20.05/01	5	571053	50.06/01	1	578159	60.01/01	22	584435	30.04/01	1
567861	90.01/08	8	571054	50.06/01	2	"	60.05/01	12	584731	90.03/01	21
567871	60.04/01	16	571061	50.06/01	1	578668	90.03/01	6	584785	60.04/01	9
568162	90.01/01	12	571062	50.06/01	2	"	90.04/02	11	584989	50.01/01	1
"	90.01/03		571149	60.05/01	17	579004	60.04/01	11	584990	50.01/01	27
"	90.02/03		571441	90.03/01	20	579558	90.03/01	10	585929	90.02/07	24
568182	90.02/01	4	571600	90.01/06	39	579560	90.03/01	24	585932	90.02/07	11
568238	50.01/01	3	571601	90.01/06	17	579562	90.03/01	16	586892	90.01/06	2
568292	90.01/01	3	571604	60.01/01	20	579877	90.03/01	2	587080	50.02/01	1
"	90.02/01	1	571609	90.01/04	25	580197	20.05/01	23	587762	90.01/08	35
568420	60.06/01	15	571610	90.01/04	26	580284	90.02/08	3	587898	90.05/02	6
568426	30.04/01	13	571612	90.01/04	9	580724	90.02/07	21	588159	60.05/01	3
568457	60.05/01	14	571616	90.01/04	8	580968	50.06/01	12	588433	20.05/01	1
568463	50.04/01	17	571707	20.05/01	26	580969	50.06/01	14	588769	90.05/01	
568478	30.01/01	4	571914	90.04/01	9	580970	50.06/01	13	588773	90.05/01	8
568716	90.03/02	2	571965	30.01/01	31	581166	90.02/07	15	588779	90.05/01	9
568719	90.03/02	3	571999	20.05/01	19	581167	90.02/07	1	589774	90.01/08	1
568721	90.03/01	17	572000	20.05/01	16	581168	90.02/07	23	590054	10.07/01	7
568722	90.03/02	10	572001	20.05/01	18	581173	90.02/07	2	590240	90.01/06	29
568723	90.03/02	11	572364	50.04/02	8	581174	90.02/07	8	590241	90.01/06	28
568725	90.03/02	12	572370	40.04/01	4	581179	90.02/08	2	592063	50.02/01	7
568779	60.04/02	22	572371	90.04/01	14	581181	90.02/08	1	592064	50.02/01	12
568781	60.04/02	21	572372	90.04/01	5	581185	90.02/08	15	592118	90.01/06	37
568896	50.01/01	22	572402	90.01/04	27	581193	90.02/08	12	592758	60.04/02	5
568910	90.03/01	5	572502	30.05/01	10	581194	90.02/08	19	592759	60.04/02	6
569171	30.04/01	2	572503	50.04/02	11	581197	90.02/08	13	592760	60.04/02	4
569412	60.01/01	6	572504	50.04/02	12	581198	90.02/08	17	593351	60.04/01	17
569436	20.05/01	11	572696	60.06/01	6	581640	90.03/02	5	593738	80.01/03	2
569437	20.05/01	10	573148	90.01/05	12	581658	90.02/01	28	594215	70.04/01	2
569438	20.05/01	9	573180	90.01/07	16	582026	90.03/02	15	594632	90.05/01	1
569625	30.01/01	5	573185	50.02/01	8	582092	90.01/04	29	594762	10.07/01	3
569683	40.04/01	13	573209	90.04/01	8	582232	30.01/01	17	594787	90.01/05	19
569842	91.01/02	7	"	90.04/02	12	582321	20.05/01	6	595050	90.03/01	12
569857	90.01/07	6	573279	90.04/01	17	582473	30.05/01	12	595165	90.03/01	22
570226	20.05/01	20	573281	90.04/01	14	582474	30.05/01	12	595174	90.03/01	19
570542	40.07/01	23	574526	10.07/05	2	582475	30.05/01	12	595686	30.06/01	15
"	40.07/02	19	576233	90.05/01	13	583198	90.02/07	16	595770	40.04/01	1
570555	90.03/01	29	576493	90.01/07	8	583319	60.05/01	6	595774	40.04/01	1
570774	60.06/01	2	576625	90.01/04	19	583545	30.02/01	1	595778	40.04/01	1
570775	60.06/01	11	576819	90.01/05	9	583546	30.02/01	23	595864	20.05/01	13
570849	30.02/01	13	577566	60.08/01	5	583582	60.04/01	4	595926	90.02/01	22

N. ORDINAZIONE	SGR	FIG	N. ORDINAZIONE	SGR	FIG	N. ORDINAZIONE	SGR	FIG	N. ORDINAZIONE	SGR	FIG
595986	30.06/01	19	722023	10.06/09	7	1909218	10.02/02	11	4585990	10.01/01	6
596152	10.07/02	15	722027	10.06/09	11	1909222	10.02/02	11	4587730	10.05/03	11
"	10.07/03	3	726381	10.06/09	5	1909229	10.02/02	11	4587731	10.05/03	10
596216	50.01/01	21	747144	10.08/03	4	1909499	10.02/01	5	4599398	10.03/02	2
596217	50.01/01	28	"	10.08/04	4	1909500	10.02/01	5	4599557	10.07/04	5
596218	50.01/01	23	765640	10.06/02	19	1909638	10.02/01	6	4599560	10.07/04	6
596219	50.01/01	12	766193	10.06/09	10	1909639	10.02/01	6	4599561	10.07/02	27
596377	90.01/07	12	766837	10.06/09	6	1909640	10.02/01	6	4599562	10.07/02	11
596421	90.01/04	24	766838	10.06/09	4	1909641	10.02/01	6	4599607	10.01/01	12
596513	20.05/01	4	766839	10.06/09	3	1909642	10.02/01	6	4599726	10.05/03	3
596516	20.05/01	2	767107	10.06/02	21	1909643	10.02/02	4	4599807	10.03/01	2
596654	90.01/01	17	767110	10.06/09	1	1909644	10.02/02	4	"	10.06/03	2
596671	90.01/08	5	767111	10.06/02	22	1909645	10.02/02	4	4599809	10.07/02	20
596673	90.01/08	22	767112	10.06/09	12	1909646	10.02/02	4	4600189	10.07/06	13
596747	10.07/01	9	767113	10.06/02	23	1909647	10.02/02	4	4600190	10.07/06	12
596854	90.01/06	35	767451	10.06/09	8	4002890	10.06/01	18	4600328	10.03/01	8
597497	90.01/04	20	768356	10.06/02		4023904	10.08/01	8	4600329	10.03/01	5
598310	10.05/02	1	768378	10.06/09	13	4023905	10.08/01	9	"	10.06/03	3
598311	10.05/02	5	770535	10.06/02	9	4031577	10.01/03	16	4600631	10.06/01	24
598643	90.01/06	10	770578	10.06/02	24	4067155	80.01/03	8	"	10.06/02	14
599098	50.01/01	24	770899	10.06/02	21	4067156	80.01/03	7	4600632	10.01/03	3
599122	70.02/01	28	770958	10.06/02	21	4068085	70.02/01	32	4600633	10.01/03	5
"	70.04/01	8	771065	10.06/02	21	"	70.04/01	10	4600753	10.01/02	23
599154	80.01/02	3	771163	10.06/09	9	4117122	80.01/01	1	4600875	10.05/01	16
599155	80.01/02	2	771326	10.06/02	18	4176086	10.08/01	19	4600893	10.05/01	14
599436	70.06/01	8	814838	60.07/01	22	4222234	80.05/02	23	4601060	10.07/02	22
599437	70.06/01	10	822483	90.03/01	23	"	80.05/03	31	4601061	10.01/01	5
599501	80.01/02	21	822977	90.03/01	3	4231247	10.03/02	31	4601295	10.03/02	15
599580	70.06/01	1	849496	80.01/01	2	4232606	10.05/01	11	4601296	10.03/02	20
599587	50.02/01	6	849603	70.04/01	41	4262887	10.05/01	17	4601302	10.03/02	27
599624	50.01/01	33	883175	90.01/01	22	4338920	10.03/02	18	4601827	10.08/02	5
599717	50.01/01	2	992273	80.01/01	10	4543282	10.06/02	4	4601981	10.08/02	6
599728	20.05/01		1909071	30.04/01	14	4551099	10.08/01	16	4602067	10.01/02	13
599730	20.05/01	7	1909165	10.01/01		4551101	10.08/01	17	4602068	10.01/02	2
599731	20.05/01	12	1909166	10.01/01		4555699	10.02/02	2	4602069	10.01/02	1
599732	60.05/01	1	1909172	10.02/02	12	4557649	10.08/01	18	4602162	10.08/02	4
599757	50.01/01	34	1909173	10.02/02	12	4564844	10.06/02	13	4602345	10.08/02	1
599758	50.01/01	35	1909174	10.02/02	12	4570798	10.03/02	10	4602601	10.02/01	9
599870	90.01/01	16	1909175	10.02/02	12	4570799	10.03/02	10	4603298	10.03/02	1
599890	90.01/05	10	1909176	10.02/02	12	4577183	10.03/02	17	4603449	10.03/02	37
607942	10.06/01	17	1909207	10.02/02	11	4578175	10.03/02	25	4603450	10.03/02	36
656829	10.06/09	2	1909214	10.02/02	11	4584861	10.07/05	3	4603451	10.03/02	35

N. ORDINAZIONE	SGR	FIG	N. ORDINAZIONE	SGR	FIG	N. ORDINAZIONE	SGR	FIG	N. ORDINAZIONE	SGR	FIG
4603862	10.07/04	2	4607934	10.01/02	12	4644327	10.06/02	8	4667450	10.06/03	4
4603870	10.07/04	9	4608223	10.05/01	9	4647814	10.06/02	16	4667451	10.03/01	7
4604615	10.07/02	23	4609132	10.03/02	16	4647958	10.07/02	30	"	10.06/03	5
4604941	10.05/03	12	4609391	10.01/01	3	4648421	10.03/02	22	4667452	90.01/02	10
4605220	10.05/01	4	4610742	10.08/03	1	4648422	10.03/02	22	"	90.02/02	10
4605293	10.05/03	4	"	10.08/04	1	4652837	10.02/01	10	4670802	10.01/02	18
4606664	10.03/01	4	4612229	10.06/01	4	4653280	10.01/01	8	4671017	10.07/02	21
"	10.07/06	9	4613792	10.08/01	3	4653281	10.01/01	8	4671700	10.06/01	19
4607466	10.01/02	32	4614608	10.05/01	19	4653282	10.01/02	8	4671701	10.06/01	28
4607511	10.03/01	10	4615697	10.06/01	9	4653283	10.01/02	9	4671840	10.03/02	7
"	10.03/02	4	4616707	10.06/01	32	4653308	10.02/02	8	4673608	10.03/02	33
4607582	90.01/02	7	4617260	10.08/01	5	4653310	10.02/02	8	4673610	10.03/02	30
"	90.02/02	7	4617262	10.08/01	10	4653311	10.02/02	8	4673692	10.05/03	6
4607586	90.01/02	9	4617425	10.06/02	10	4653312	10.02/02	8	4673807	10.07/02	3
"	90.02/02	9	4617972	10.06/01	27	4653313	10.02/02	8	4673810	10.07/02	6
4607590	90.01/02	2	4619233	10.06/01	7	4653314	10.02/02	10	4673811	90.01/02	11
"	90.01/02	14	4619405	90.01/02	12	4653316	10.02/02	10	4676070	10.03/02	32
"	90.02/02	2	"	90.02/02	12	4653317	10.02/02	10	4676071	10.03/02	32
"	90.02/02	14	4620989	10.06/01	30	4653318	10.02/02	10	4676518	10.02/01	11
4607593	90.01/02	15	4621357	90.02/02	11	4653319	10.02/02	10	4679242	10.07/02	9
"	90.02/02	15	4621430	10.06/01	11	4653321	10.02/02	9	"	10.07/04	
4607627	10.06/02	15	4621434	10.06/01	34	4653323	10.02/02	9	4682985	10.01/01	21
4607639	10.01/03	18	4621436	10.06/01	33	4653324	10.02/02	9	4689554	10.03/02	26
4607641	10.01/03	12	4621511	10.03/02	29	4653325	10.02/02	9	4690375	10.01/01	26
4607643	10.01/03	17	4621730	10.01/03	8	4653326	10.02/02	9	4693029	10.03/02	34
4607646	10.06/03	7	4621740	10.06/07	4	4654360	10.01/01	4	4693030	10.03/02	34
4607647	10.06/03	8	"	10.06/08	4	4654361	10.01/01	20	4693031	10.03/02	34
4607651	10.06/03	16	4622324	10.07/06	10	4654391	10.01/02	27	4693032	10.03/02	34
4607652	10.06/03	15	4622850	10.03/02	21	4655011	10.07/04	1	4697838	10.07/02	12
4607654	10.06/03	1	4622851	10.01/02	29	4655014	10.07/05	6	4699783	10.03/02	19
4607655	10.06/01	25	4624515	10.05/01	18	4655844	10.02/01	4	4700829	10.02/02	3
"	10.06/03	6	4624702	10.05/01	10	4656176	10.01/02	22	4702448	80.04/01	9
4607670	10.05/01	2	4624737	10.07/06	6	4657434	10.01/02	10	4702453	80.04/01	15
4607673	10.06/01	21	4625173	10.03/02	23	4658441	10.01/02	30	4702454	10.07/06	2
4607721	10.06/03	12	4628797	10.01/01	27	4659056	10.01/03	11	"	80.04/01	10
4607722	10.06/03	10	4639096	10.07/04	8	4660759	10.01/02	14	4702455	10.07/02	14
4607743	10.03/01	1	4639097	10.07/04	7	4661543	10.07/02	19	"	10.07/06	1
4607764	10.02/01	3	4639661	10.03/02	10	4662614	10.06/03	9	4702456	80.04/01	16
"	10.03/01	3	4641875	10.06/02	5	4663606	10.02/02	6	4702457	80.04/01	17
4607842	10.08/02	9	4641876	10.06/02	3	4663607	10.02/02	6	4702548	10.07/06	5
4607909	10.01/02	5	4644325	10.06/02	6	4666429	10.07/06	8	4703088	10.07/02	1
4607933	10.01/02	4	4644326	10.06/02	7	4667450	10.03/01	6	4705827	10.05/01	22

N. ORDINAZIONE	SGR	FIG	N. ORDINAZIONE	SGR	FIG	N. ORDINAZIONE	SGR	FIG	N. ORDINAZIONE	SGR	FIG
4705827	10.05/03		4951027	90.04/01	1	4953797	90.02/01	33	4956604	90.02/01	25
4705829	10.05/03	13	"	90.04/02	1	4953803	90.02/05	3	4956606	90.02/06	3
4705831	10.05/03	2	4951032	90.03/01	18	4953805	90.02/01	34	4956608	90.02/06	5
4705833	10.05/03	5	4951034	90.04/02	10	4953823	90.02/07	3	4956614	90.02/04	3
4705834	10.05/03	1	4951113	90.03/01	18	4953838	10.07/01	8	4956626	90.02/01	26
4705835	10.05/01	8	4951135	80.05/02	21	4953858	90.02/07	14	"	90.02/07	
4705910	10.05/01	7	4951136	70.04/01	42	4953875	60.06/01	1	4956716	90.02/05	5
4707153	10.05/03	9	4951360	60.07/01	13	4953880	90.02/01	30	4956776	70.06/02	4
4710517	10.01/01	15	4951439	30.02/01	22	4953881	90.02/01	13	4956777	70.06/02	6
4710518	10.01/01	14	4951440	30.02/01	27	4953882	90.02/01	10	4956787	30.06/01	12
4712886	10.02/02	5	4951711	60.07/01	11	4953883	90.02/01	11	4956788	70.06/02	13
4712888	10.02/02	5	4951719	60.07/01	17	4953953	10.07/01	2	4956791	70.06/02	7
4712889	10.02/02	5	4951721	60.07/01	18	4953958	10.07/03	1	4956794	90.02/08	11
4712890	10.02/02	5	4952471	80.01/01	23	4954117	80.04/01	20	4956828	70.03/01	1
4712891	10.02/02	5	4952473	10.07/01	6	"	80.05/01	18	4956836	70.06/02	12
4713391	10.01/01	7	4952488	80.01/03	10	4954205	50.04/01	22	4956839	70.06/02	11
4714777	10.07/05	1	4952523	50.01/01	20	4954251	60.07/01	19	4956888	70.03/01	7
4717707	70.04/01	39	4952580	70.06/01	14	4954430	50.01/01	8	4957350	50.04/01	9
4721863	80.04/01	4	4952618	80.01/01	15	4954645	60.07/01	20	4957353	50.04/01	8
4737534	10.02/01	7	4952624	60.04/02	7	4954714	50.04/02	2	4957534	80.01/03	12
4738369	10.02/01	1	4952678	30.01/01	24	"	60.01/01	5	4957540	80.01/03	13
4740717	10.06/01	8	4952813	80.01/01	8	4955386	50.01/01	32	4957544	80.01/03	11
4763918	10.02/02	1	4952815	80.01/01	5	4955420	90.01/04	16	4958117	70.05/02	9
4950002	10.07/01	1	4952816	80.01/01	13	4955421	90.01/04	17	4958366	50.05/01	4
4950003	10.07/01	10	4952817	80.01/01	17	4955740	80.01/03	6	4958507	50.04/01	7
4950005	10.07/01	19	4952977	50.01/01	6	4955798	80.01/03	5	4958508	30.01/01	44
4950071	30.05/01	11	4953207	40.04/01	2	4955799	80.01/03	4	"	50.04/01	16
4950098	30.01/01	12	4953364	40.07/01	15	4955800	80.01/03	1	4958977	90.04/01	18
4950177	10.07/01	18	4953365	40.07/01	15	4956119	10.07/02	17	4959009	80.01/02	15
4950544	70.06/01	4	4953366	40.07/02	1	4956141	90.04/02	8	4959075	90.02/06	4
4950545	70.06/01	11	4953367	50.04/02	3	4956516	30.01/02	1	4959911	30.02/01	25
4950546	70.06/01	15	4953409	50.01/01	18	4956580	90.02/04	17	4959916	30.06/01	13
4950689	70.05/01	12	4953417	40.04/01	8	4956581	90.02/04	13	4959963	50.06/01	1
4950756	90.03/02	6	4953668	30.01/02	5	4956583	90.02/04	14	4959998	50.06/01	2
4950863	80.01/01	3	4953677	90.02/08	25	4956585	90.02/06	7	4960041	30.02/01	4
4950882	10.07/01	4	4953759	90.02/04	9	4956587	90.02/06	8	"	30.06/01	6
4951021	90.04/01	13	4953760	90.02/04	12	4956588	90.02/06	9	4960130	50.05/01	4
"	90.04/02	9	4953766	90.02/05	6	4956589	90.02/06	1	4960158	91.01/02	
4951022	90.04/01	12	4953768	30.01/02	8	4956591	90.02/06	6	4960799	50.06/01	4
"	90.04/02	14	4953792	90.02/07	22	4956592	90.02/01	21	4960851	60.04/02	16
4951024	90.04/01	2	4953793	90.02/08	24	4956597	90.02/06	2	4960953	50.03/01	2
"	90.04/02	2	4953794	90.02/08	20	4956599	90.02/05	1	4960954	50.03/01	1

N. ORDINAZIONE	SGR	FIG	N. ORDINAZIONE	SGR	FIG	N. ORDINAZIONE	SGR	FIG	N. ORDINAZIONE	SGR	FIG
4960958	50.03/01	5	4968690	50.05/02	7	4973996	80.01/02	12	4984223	60.04/02	19
4960979	50.05/02	6	4968691	50.05/02	10	4975018	70.03/01	9	4984280	20.05/01	24
4960980	50.05/02	33	4968695	50.05/03	1	4975196	50.04/01	24	4984282	20.05/01	17
4960981	50.05/02	21	4968813	50.04/01	18	4975198	50.04/01	1	4987044	90.01/08	18
4960982	50.05/02	22	"	60.05/01	2	4975657	90.02/01	15	4987809	90.01/06	32
4960985	50.03/02	1	"	90.01/04	30	4975658	90.02/01	25	4988024	70.04/01	29
4960986	50.01/01	1	4968815	90.01/06	30	4976069	30.01/01	28	4988025	70.04/01	30
4960987	50.01/01	27	"	90.01/07	10	4976071	90.01/04	12	4988553	10.02/01	8
4960988	50.01/01	1	4969393	60.05/01	20	4976938	60.04/02	10	4988618	10.07/03	5
4960989	50.01/01	27	4969426	50.06/01	17	4978258	30.01/01	13	4988619	10.07/03	6
4960991	50.06/01	17	4969575	40.04/01	1	4978731	70.03/01	8	4988636	80.04/01	13
4960993	50.06/01	16	4969835	50.06/01	17	4979602	80.01/01	14	"	80.04/02	
4960995	70.07/01	1	4970273	40.04/01	1	4980622	91.01/02	12	4988637	80.04/03	9
4960996	70.07/01	8	4970275	40.04/01	1	4981481	90.01/05	1	4988638	80.04/03	14
4960999	70.07/01	9	4970305	60.06/01	9	4981483	90.01/05	13	4988639	80.04/02	6
4961001	70.07/01	7	4970715	30.06/01	8	4981484	90.01/05	20	4988640	80.04/02	13
4961052	50.01/01	2	4970717	30.06/01	5	4981485	90.01/05	3	4988641	80.04/02	20
4961053	50.01/01	6	4970998	10.07/01	6	4981488	90.01/05	14	4988642	80.04/02	22
4961064	50.03/02	2	4970999	10.07/01	13	4981489	90.01/05	23	4988643	80.04/02	21
4961065	50.03/02	2	4971045	50.05/02	25	4981724	70.05/01	9	4988644	80.04/02	15
4961078	50.03/02	2	4971553	80.01/01	6	4981746	91.01/02	10	4988645	80.04/02	23
4961134	50.01/01	10	4971673	60.04/01	2	4981884	70.05/02	7	4988646	80.04/02	16
4961252	60.04/02	15	4971772	60.04/01	7	4982242	90.01/07	8	4988649	80.04/02	24
4963663	80.01/02	9	4971773	60.04/01	5	4982381	90.01/08	20	4988652	80.04/02	17
4964324	50.01/01	2	4971982	90.02/07	17	4982383	90.01/05	11	4988653	80.04/02	18
4964325	50.01/01	6	4973149	50.05/04	14	4982388	90.01/05	16	"	80.04/03	25
4964326	50.01/01	5	4973150	50.05/04	13	4982404	90.01/08	11	4988654	80.04/02	5
4964330	90.02/04	10	4973151	50.05/04	2	4982463	90.01/05	1	4988655	80.04/02	14
4964331	90.02/04	11	4973152	50.05/04	12	4982465	90.01/05	13	4988656	80.04/02	25
4964332	90.02/04	5	4973153	50.05/03	4	4983094	90.01/08	9	4988658	80.04/03	4
4964333	50.01/01	9	"	50.05/04	7	4983101	90.01/08	16	4988659	80.04/03	27
4964334	50.01/01	8	4973154	50.05/03	5	4983237	91.01/02	11	4988660	80.04/03	3
4964348	90.03/02	16	"	50.05/04	6	4983307	90.03/01	9	4988661	80.04/02	9
4964349	90.03/02	13	4973156	50.05/04	11	"	90.03/02		4988662	80.04/02	1
4966283	50.02/01	4	4973157	50.05/04	10	4983308	90.03/02	17	4988663	80.04/02	3
4967255	91.01/02	9	4973165	70.07/01	5	4983311	90.03/01	4	4988664	80.04/02	2
4967333	90.02/07	20	4973166	70.07/01	6	4983317	90.01/01	19	4988666	80.04/02	12
4967412	80.04/01	21	4973167	70.07/01	11	4983391	90.01/04	15	4988667	80.04/03	1
4967704	50.02/01	5	4973168	70.07/01	12	4983527	40.07/02	12	4988670	80.04/03	17
"	90.03/01	8	4973366	50.05/03	6	4983528	40.07/02	12	4988672	80.04/03	22
4968573	50.05/04		"	50.05/04	1	4983650	90.03/01	24	4988673	80.04/03	5
4968623	50.05/02	2	4973421	50.05/03	2	4983949	90.01/07	4	4988674	80.04/03	23

N. ORDINAZIONE	SGR	FIG	N. ORDINAZIONE	SGR	FIG	N. ORDINAZIONE	SGR	FIG	N. ORDINAZIONE	SGR	FIG
4988675	80.04/03	21	4998886	90.05/01	10	5106928	70.05/02	2	5116031	70.03/01	15
4988676	80.04/03	24	4998888	90.05/01	20	5106930	70.05/02	1	5116211	90.01/06	12
4988677	80.04/02	10	4999664	90.01/06	34	5106932	70.05/02	3	5116481	80.01/02	17
4988678	80.04/03	20	4999850	60.07/01	10	5107047	60.01/01	21	5116508	70.03/01	13
4988683	80.04/03	6	5011696	80.05/02	16	5107048	60.01/01	7	5116516	70.03/01	14
4988686	80.04/03	10	"	80.05/03	18	5107399	30.01/01	42	5116537	70.02/01	20
4988687	80.04/03	12	5011812	30.01/01	8	5107402	30.01/01	42	"	70.04/01	11
4988688	80.04/03	26	5011871	50.06/01	8	5107403	60.01/01	9	5117579	70.03/01	10
4988696	80.04/03	8	5011951	50.06/01	7	5107603	10.05/02	4	5117580	70.03/01	17
4988697	80.04/02	7	5011952	50.06/01	15	5107816	30.02/01	11	5117583	70.04/01	37
4989136	90.03/02	1	5100804	90.01/06	19	5107817	30.06/02	24	5117585	70.04/01	35
4989141	90.03/01	15	5100806	90.01/06	21	5108206	10.05/02	3	5117594	60.05/01	4
4989839	91.01/01	1	5100807	90.01/06	18	"	10.07/03	4	5117596	60.01/01	1
4990251	50.06/01	4	5101590	30.02/01	8	5108833	50.04/02	13	5117598	60.01/01	24
4990252	50.06/01	4	5101777	40.07/01	11	5109079	40.07/01	17	5117600	70.03/01	20
4990945	10.08/03	6	5101778	40.07/02	6	"	40.07/02	13	5117607	10.08/04	6
4991597	90.05/02	1	5101910	90.01/06	16	5109270	80.01/01	16	5117608	10.08/04	5
4991598	90.05/02	2	5102303	40.04/01	17	5109313	50.04/01	21	5117609	10.08/04	19
4991599	90.05/02	5	5102349	30.06/01	14	5109317	50.04/01	19	5117610	10.08/03	11
4991682	30.05/01	16	5102663	30.01/01	9	5109321	50.04/01	10	"	10.08/04	7
4991683	30.05/01	16	5102993	90.03/01	7	5109322	50.04/01	11	5117611	10.08/04	12
4991684	30.05/01	16	5103002	90.03/01	7	5109324	50.04/01	20	5117612	10.08/04	2
4994520	50.06/01	1	5103005	90.03/01	11	5109356	70.04/01	44	5117618	10.08/03	5
4994521	50.06/01	2	5103028	90.01/04	4	5109513	80.05/02	30	5117619	10.08/03	7
4996277	30.02/01	10	5103030	90.02/01	24	5109937	50.04/02	9	5118066	10.08/03	2
4996420	90.01/06	3	5103051	30.01/01	41	5110164	90.01/09	10	5118068	10.08/04	11
4996823	70.05/01	2	5103242	30.01/01	10	5110167	90.01/08	28	5118070	90.01/09	13
4996825	70.05/01	1	5103288	50.04/01	5	5110170	90.01/09	1	5118071	70.05/02	9
4996827	70.05/01	3	5103289	50.04/01	6	5110179	90.01/09	11	5118210	70.04/01	27
4996828	70.05/01	10	5103306	50.04/01	2	5110181	91.01/03	2	5118211	70.04/01	32
4997629	70.03/01	11	5103320	30.04/01	8	5110185	90.01/07	5	5118212	70.04/01	36
4998213	50.05/02	28	5103446	91.01/02	13	5110186	90.01/09	12	5118499	10.07/02	33
4998391	70.04/01	47	5103800	30.06/02	17	5110190	90.01/09	2	5118568	90.01/01	6
4998655	90.05/01	16	5103801	30.06/02	6	5110213	90.01/08	33	"	90.02/01	16
4998656	90.05/01	18	5103893	30.06/02	25	5110247	90.01/01	24	5118569	90.01/01	9
4998680	70.04/01	28	5103898	30.06/02	2	5111319	80.04/01	1	"	90.02/01	19
4998710	70.04/01	21	5104083	90.05/02	8	"	80.04/04		5118570	90.01/01	8
4998806	80.01/01	9	5104725	50.04/02	14	5111551	90.01/07	3	"	90.02/01	18
4998815	90.01/05	21	5105663	90.01/05	8	5111552	90.01/07	15	5119573	60.07/01	3
4998867	90.01/08	19	5105664	90.01/05	6	5114353	50.05/02	14	5119577	70.04/01	16
4998868	90.01/05	2	5105989	30.06/02	4	5114572	50.03/01	8	5119579	70.04/01	15
4998870	70.04/01	38	5106081	50.04/02	1	5114573	50.03/01	9	5119581	70.02/01	9

N. ORDINAZIONE	SGR	FIG	N. ORDINAZIONE	SGR	FIG	N. ORDINAZIONE	SGR	FIG	N. ORDINAZIONE	SGR	FIG
5119585	70.02/01	21	8273940	90.02/03	14	9917923	10.06/04	26	9917985	10.06/04	38
5119603	70.04/01	1	8274231	90.01/03	15	9917924	10.06/04	40	9917987	10.06/05	16
5119843	80.05/02	4	"	90.02/03	15	9917925	10.06/04	39	9917991	10.06/05	38
"	80.05/03	10	8280168	90.01/03	16	9917926	10.06/04	54	9917993	10.06/04	63
5119845	80.05/02	28	"	90.02/03	16	9917927	10.06/04	2	9917997	10.06/04	62
"	80.05/03	14	8280170	90.01/03	17	9917930	10.06/04	35	9917998	10.06/05	36
5119847	80.05/02	32	"	90.02/03	17	9917931	10.06/04	17	9918000	10.06/04	28
"	80.05/03	17	8281201	90.01/03	18	9917932	10.06/04	31	9918001	10.06/04	55
5119917	80.05/02	3	"	90.02/03	18	9917934	10.06/04	15	9918092	10.06/04	65
5120324	80.05/02		8281576	90.01/03		9917936	10.06/04	11	9918095	10.06/04	51
5120362	80.05/02	7	"	90.02/03		9917937	10.06/04	22	"	10.06/05	2
5121195	90.01/01	24	8283478	90.01/03	19	9917938	10.06/04	25	9918096	10.06/04	50
5121196	90.01/09	12	"	90.02/03	19	9917946	10.06/04	18	"	10.06/05	1
8273908	90.01/03	1	9902481	80.04/04	18	9917947	10.06/04	18	9918103	10.06/07	6
"	90.02/03	1	9907163	80.05/03	19	9917948	10.06/04	33	"	10.06/08	6
8273909	90.01/03	2	9909170	80.04/04	41	9917949	10.06/04	27	9918104	10.06/07	16
"	90.02/03	2	9909440	80.04/04	24	9917950	10.06/04	10	"	10.06/08	8
8273910	90.01/03	3	9909452	80.04/04	26	"	10.06/07	3	9918105	10.06/07	5
"	90.02/03	3	9917886	10.06/05	12	"	10.06/08	3	"	10.06/08	5
8273911	90.01/03	4	9917887	10.06/05	10	9917951	10.06/04	24	9918107	10.06/07	14
"	90.02/03	4	9917888	10.06/05	9	9917952	10.06/04	3	9918110	10.06/07	13
8273912	90.01/03	5	9917889	10.06/05	11	9917953	10.06/04	1	9918111	10.06/07	15
"	90.02/03	5	9917890	10.06/05	6	"	10.06/04	23	"	10.06/08	9
8273913	90.01/03	6	9917892	10.06/05	8	9917954	10.06/04	12	9918123	10.06/07	7
"	90.02/03	6	9917893	10.06/05	5	9917955	10.06/04	20	9918124	10.06/07	8
8273914	90.01/03	7	9917894	10.06/05	3	9917956	10.06/04	14	9918125	10.06/07	11
"	90.02/03	7	9917895	10.06/05	4	9917957	10.06/04	30	9918145	10.06/07	10
8273915	90.01/03	8	9917897	10.06/05	15	9917958	10.06/04	29	9918182	10.06/05	7
"	90.02/03	8	9917898	10.06/05	18	9917959	10.06/04	21	9918385	10.06/07	1
8273916	90.01/03	9	9917899	10.06/05	17	9917960	10.06/04	7	"	10.06/08	1
"	90.02/03	9	9917900	10.06/05	24	9917961	10.06/04	8	9918386	10.06/08	7
8273917	90.01/03	10	9917901	10.06/05	27	9917962	10.06/04	9	9918431	80.05/03	25
"	90.02/03	10	9917902	10.06/05	26	9917964	10.06/04	4	9918433	80.05/03	30
8273918	90.01/03	11	9917903	10.06/05	19	9917965	10.06/04	6	9918434	80.05/03	28
"	90.02/03	11	9917904	10.06/05	22	9917967	10.06/04	43	9918988	10.06/04	52
8273919	90.01/02	17	9917905	10.06/05	20	9917969	10.06/04	70	9919164	10.06/07	9
"	90.01/03	12	9917908	10.06/04	36	9917971	10.06/04	59	9919569	10.06/04	45
"	90.02/03	12	9917914	10.06/05	29	9917975	10.06/04	42	9919575	10.06/04	46
8273920	90.01/02	18	9917916	10.06/05	31	9917976	10.06/04	66	9919576	10.06/04	48
"	90.01/03	13	9917920	10.06/04	56	9917978	10.06/04	67	9920107	10.06/04	53
"	90.02/03	13	9917921	10.06/05	34	9917979	10.06/04	65	"	10.06/05	21
8273940	90.01/03	14	9917922	10.06/04	57	9917981	10.06/04	44	9922900	10.06/04	37

N. ORDINAZIONE	SGR	FIG	N. ORDINAZIONE	SGR	FIG	N. ORDINAZIONE	SGR	FIG	N. ORDINAZIONE	SGR	FIG
9922901	10.06/05	30	9927918	10.06/06	1	9956550	80.04/04	23	10206320	80.04/02	11
9922902	10.06/05	25	9927920	10.06/06	3	9956552	80.04/04	35	10248011	60.07/01	16
9922903	10.06/05	35	9928366	10.06/10	4	9956553	80.04/04	34	10257060	90.02/01	32
9922904	10.06/05	35	9928367	10.06/10	1	9956554	80.04/04	30	"	90.02/07	4
9922907	10.06/04	60	9928369	10.06/10	6	9956555	80.04/04	38	"	90.05/02	4
9922908	10.06/04	64	9928370	10.06/10	7	9956556	80.04/04	37	10260060	10.05/01	13
9922909	10.06/04	41	9928371	10.06/10	5	9956557	80.04/04	27	"	90.02/01	29
9922910	10.06/04	68	9928373	10.06/10	10	9956558	80.04/04	32	"	90.05/01	15
9922913	10.06/04	65	9928374	10.06/10	3	9956559	80.04/04	13	10260160	10.06/01	12
9922914	10.06/04	65	9928375	10.06/10	8	9957295	10.06/04	19	10263160	90.02/07	13
9922915	10.06/04	71	9928376	10.06/10	9	9957574	80.04/04	29	10263460	10.01/02	16
9922916	10.06/04	61	9928391	10.06/11	2	9957705	80.04/04	16	"	30.01/02	4
9922917	10.06/04	69	9928392	10.06/11	1	9957709	80.04/04	14	"	40.04/01	7
9923012	10.06/05	35	9928396	10.06/10	2	9957710	80.04/04	15	10264360	80.01/01	21
9923014	10.06/04	58	9928452	80.04/04	28	9957819	10.06/05	37	10265360	90.01/04	14
9924369	10.06/06	4	9928676	80.05/03	22	9957842	10.06/06	2	10278660	10.07/02	32
9925951	10.06/05	13	9929579	10.06/04	47	9957913	80.04/04	39	"	90.02/07	19
9926919	10.06/05	33	9929585	10.06/04	16	9957964	80.04/04	5	"	90.05/01	12
9927027	80.05/03	32	9929587	10.06/05	14	9957965	80.04/04	9	10280060	10.06/01	1
9927290	80.05/03	21	9929597	10.06/04	49	10007109	80.01/01	7	10284460	50.05/02	9
9927292	80.05/03	26	9929838	80.05/03	3	10033211	60.07/01	12	10287380	91.01/02	15
9927293	80.05/03	24	9929839	80.05/03	5	10053510	30.04/01	7	10287385	90.01/04	6
9927294	80.05/03	20	9929841	80.05/03	8	"	60.04/02	13	10291290	90.02/04	8
9927697	10.06/04	5	9929842	80.05/03	2	10053610	40.04/01	19	10296160	10.06/01	6
9927703	10.06/05	32	9929843	80.05/03	6	"	60.04/01	12	10296260	90.01/06	22
9927787	80.04/04	6	9930019	10.06/11	6	"	90.01/05	18	10298460	10.05/02	2
9927789	80.04/04	36	9930020	10.06/11	12	10054110	60.01/01	4	10300511	90.01/04	7
9927795	80.04/04	7	9930021	10.06/11	11	10124511	90.01/09	5	10300711	90.05/01	11
9927796	80.04/04	8	9930022	10.06/11	3	10125171	10.01/02	26	10305140	80.01/01	22
9927797	80.04/04	10	9930023	10.06/11	8	10125576	90.01/09	4	10305171	10.01/02	17
9927798	80.04/04	11	9930024	10.06/11	5	10158300	30.02/01	29	"	30.01/02	3
9927799	80.04/04	12	9930025	10.06/11	4	10160701	10.01/01	10	"	40.04/01	6
9927800	80.04/04	20	9930026	10.06/11	7	10181711	10.06/01	5	10329910	10.03/02	28
9927801	80.04/04	21	9930027	10.06/11	9	10184311	10.06/01	14	10375101	80.04/03	19
9927802	80.04/04	22	9931247	10.06/11	10	10184411	90.02/01	31	10389901	10.08/01	6
9927806	80.04/04	4	9933229	80.04/04	40	10184417	90.05/02	3	10396180	70.04/01	14
9927813	80.04/04	2	9933234	80.04/04	25	10205710	90.05/01	6	10405585	80.04/01	14
9927815	80.04/04	19	9934288	80.04/04	17	10205810	60.04/02	1	10516470	10.07/01	12
9927911	10.06/07	2	9956254	10.06/05	28	10205910	10.03/01	11	10516471	80.04/03	11
"	10.06/08	2	9956295	10.06/04	34	"	10.03/02	3	"	90.02/08	9
9927916	10.06/07	12	9956300	10.06/05	23	"	20.05/01	21	10516671	10.08/03	3
"	10.06/08	10	9956304	10.06/04	13	10206020	60.01/01	23	"	10.08/04	3

N. ORDINAZIONE	SGR	FIG	N. ORDINAZIONE	SGR	FIG	N. ORDINAZIONE	SGR	FIG	N. ORDINAZIONE	SGR	FIG
10516671	10.08/04	9	10517071	50.03/01	6	10519621	10.07/02	13	10791011	60.05/01	18
"	30.01/01	16	"	50.05/02	5	10519660	10.01/01	19	"	80.05/02	22
"	30.01/01	23	"	50.05/04	3	10520001	10.08/04	18	"	90.05/01	4
"	30.01/02	6	"	60.05/01	7	"	50.04/01	4	10791211	50.04/02	6
"	30.02/01	5	"	70.03/01	3	"	60.05/01	16	10791411	70.02/01	24
"	30.06/01	17	"	70.07/01	13	"	70.03/01	6	10793511	60.01/01	19
"	50.04/01	15	"	90.01/04	18	"	90.01/08	24	10794011	80.01/01	12
"	50.05/01	2	"	90.04/01	3	10520101	30.01/01	34	"	80.04/02	19
"	60.04/02	3	"	90.04/02	3	"	30.01/02	11	"	80.04/03	18
"	60.08/01	9	10517170	50.02/01	14	10520501	60.06/01	5	10796401	50.04/01	13
"	90.01/01	2	10517171	30.01/01	29	10535001	30.06/02	8	"	60.06/01	8
"	90.01/04	2	"	70.03/01	5	10538400	40.07/01	6	10796601	50.05/02	34
"	90.01/06	27	"	70.06/01	7	10538500	40.07/01	6	10797001	60.01/01	13
"	90.01/08	15	"	70.06/02	9	"	40.07/02	5	10797401	60.06/01	4
"	90.02/01	2	"	90.01/01	15	10545700	50.01/01	7	10798101	30.01/01	11
"	90.02/04	6	"	90.01/05	4	10546900	50.05/02	12	10839510	10.05/03	8
"	90.02/07	6	"	90.01/06	7	10572171	80.04/02	8	10839610	10.01/03	10
"	90.03/02	8	"	90.01/09	8	10581871	90.01/09	15	10839710	10.01/02	28
10516870	70.04/01	25	"	90.02/04	2	10617010	90.01/08	17	"	30.01/01	43
"	91.01/03	3	"	90.02/05	7	10724711	90.04/01	7	10839810	30.04/01	10
10516871	10.08/04	13	10517270	50.02/01	3	10725911	90.02/08	18	"	40.04/01	5
"	30.01/01	3	10517271	50.01/01	15	10726711	60.01/01	3	10839910	30.01/01	45
"	50.01/01	13	"	50.05/02	26	10733601	60.05/01	15	"	40.04/01	5
"	60.01/01	15	10517371	90.03/01	13	"	90.01/08	23	10857790	80.05/03	13
"	60.06/01	17	10517471	90.04/01	10	10733801	90.04/01	6	10861290	80.05/03	27
"	70.03/01	19	"	90.04/02	6	10734201	10.08/03	9	10902011	10.07/01	11
"	70.05/01	7	10517671	30.06/02	10	"	60.05/01	11	10902121	70.02/01	14
"	70.05/02	5	10519301	80.04/04	3	"	60.06/01	12	10902321	90.01/02	3
"	70.06/01	3	10519401	60.07/01	5	"	60.07/01	21	"	90.02/02	3
"	70.06/02	2	"	70.02/01	29	"	90.01/07	1	10902421	10.06/01	15
"	70.07/01	3	"	70.04/01	7	"	90.01/08	2	10902821	80.04/01	5
"	90.01/06	14	"	90.01/01	5	10734301	90.02/08	14	10903021	90.01/01	4
"	90.01/08	25	"	90.02/01	5	10734401	70.04/01	12	"	90.02/01	6
"	90.02/01	9	10519411	70.02/01	15	10734601	60.07/01	6	10922921	70.06/01	9
"	90.02/04	16	10519601	10.08/02	7	10788811	60.07/01	14	10923321	60.01/01	14
"	90.03/01	27	"	10.08/03	8	10790111	90.01/06	24	10935521	30.06/02	30
"	90.05/01	3	"	30.06/01	18	10790311	30.01/01	26	10944921	60.05/01	8
"	91.01/01	3	"	60.04/02	9	"	40.04/01	15	10978021	10.06/02	1
10517070	10.07/01	5	"	70.04/01	13	10790321	90.01/04	23	10979321	70.04/01	23
10517071	30.01/01	7	"	80.01/02	6	10790411	90.01/01	18	10979421	20.05/01	8
"	30.06/02	29	"	90.01/07	2	"	90.01/06	8	11059076	10.02/02	7
"	40.04/01	9	"	90.02/01	27	10791011	50.01/01	4	11059976	60.04/02	20

N. ORDINAZIONE	SGR	FIG	N. ORDINAZIONE	SGR	FIG	N. ORDINAZIONE	SGR	FIG	N. ORDINAZIONE	SGR	FIG
11061576	30.06/01	20	11198371	10.06/01	2	11390521	50.02/01	2	12164711	91.01/03	4
11061976	30.06/01	11	"	10.07/02	7	11394321	30.01/02	9	12164721	90.03/01	28
"	30.06/02	1	"	10.07/06	3	11408321	10.01/02	31	12164740	10.07/02	26
11066076	90.01/04	21	"	30.01/01	19	"	30.01/01	30	12170790	80.01/02	20
11066676	10.03/02	9	"	80.04/01	3	"	70.06/01	6	12174090	10.07/02	16
11067876	30.06/02	5	11198671	30.01/01	38	"	90.01/05	5	12174790	10.07/03	2
11068876	30.02/01	24	11200171	10.06/03	13	"	90.02/04	1	12174890	80.01/02	14
"	30.06/01	3	"	30.01/01	32	11408621	90.04/02	5	"	80.01/02	16
11069376	40.07/01	2	"	30.01/02	10	11422321	70.03/01	4	12179090	10.08/01	2
11075476	40.07/01	3	"	90.04/01	19	"	70.06/01	5	12179490	10.08/01	1
11087676	70.02/01	19	11200271	30.01/01	35	"	90.01/09	7	"	80.01/01	4
11088075	90.02/08	16	11201121	30.01/01	39	11693811	50.05/02	35	12237701	70.05/01	11
11106021	80.01/03	14	11227021	90.01/01	14	11701711	80.01/03	15	"	70.05/02	10
11195370	80.05/03	29	11227721	30.01/01	20	11794530	90.01/04	22	12430121	10.01/02	33
11195371	80.01/01	11	11234721	10.07/02	29	11794620	40.04/01	10	12574111	90.02/08	21
"	80.04/02	4	11244421	30.04/01	3	11794720	30.01/01	27	12574211	80.04/04	33
"	80.04/03	7	11254121	40.04/01	3	11796320	10.08/04	17	"	80.05/03	9
11195471	10.06/02	2	11306921	10.01/02	24	"	40.04/01	11	12574511	10.07/01	14
"	10.08/01	13	"	10.06/01	3	11798020	90.01/01	23	"	80.01/01	19
"	80.04/03	15	"	10.07/01	16	11798120	90.01/06	6	"	80.05/02	15
"	80.04/04	1	"	40.04/01	21	11902017	10.08/01	14	12598879	10.08/04	20
11197771	10.06/01	16	"	70.05/01	4	11903171	50.05/02	8	12605571	90.02/08	22
"	90.01/02	4	"	80.04/01	2	12163911	10.08/04	21	12605679	50.05/02	16
"	90.02/02	4	"	90.01/08	4	"	40.04/01	15	12638601	10.07/01	15
11198071	10.01/01	2	"	90.03/01	26	12164011	50.02/01	13	"	60.06/01	7
"	10.01/02	7	"	91.01/01	4	"	90.01/09	9	"	70.05/01	6
"	10.01/03	2	"	91.01/03	1	12164111	50.02/01	10	"	70.06/02	5
"	10.03/02	6	11306971	80.04/01	12	12164211	90.03/01	14	"	70.07/01	2
"	10.05/01	6	11307021	10.01/02	11	12164311	90.04/01	15	"	90.01/07	14
"	10.05/03	14	"	10.07/02	24	"	90.04/02	15	12639701	80.01/03	9
"	10.06/01	23	"	60.01/01	16	12164711	10.06/01	13	12642701	60.05/01	10
"	10.06/02	12	11307721	30.01/01	37	"	10.07/06	4	"	90.01/08	3
"	10.06/02	18	11359921	30.01/01	33	"	70.05/01	8	"	90.02/08	28
"	10.07/02	5	11360221	10.01/02	25	"	70.05/02	6	12644401	90.02/08	10
"	10.07/05	4	11363021	30.01/01	1	"	70.06/01	13	12646801	60.06/01	16
"	10.08/01	11	"	90.01/04	28	"	70.06/02	3	13103611	80.05/02	13
"	10.08/02	3	"	90.04/01	4	"	70.07/01	15	"	80.05/02	12
"	80.04/01	18	"	90.04/02	4	"	80.04/01	11	13272011	80.05/02	12
"	90.01/02	6	11369621	30.01/01	40	"	90.01/08	27	13273801	80.05/03	33
"	90.02/02	6	11376221	50.02/01	16	"	90.01/09	16	13274011	70.04/01	17
11198371	10.01/02	3	"	50.05/02	31	"	90.05/02	9	13274611	80.05/01	10
"	10.01/03	15	11390521	50.01/01	25	"	91.01/01	2	"	80.05/02	1
									13274911	70.04/01	49

N. ORDINAZIONE	SGR	FIG	N. ORDINAZIONE	SGR	FIG	N. ORDINAZIONE	SGR	FIG	N. ORDINAZIONE	SGR	FIG
13274911	80.05/02	26	14148190	80.05/03	12	14324901	90.01/06	33	14583371	91.01/02	1
13276011	70.02/01	30	14161970	20.05/01	15	"	90.05/01	17	14583471	91.01/02	2
"	70.04/01	6	14164170	60.08/01	7	14325001	10.07/04	3	14584431	91.01/02	5
"	80.05/01	2	"	90.02/08	6	14325101	10.05/03	7	14585471	91.01/02	4
13280411	70.02/01	3	14165470	10.07/06	11	14325701	10.07/02	31	14586071	91.01/02	6
13301301	90.02/08	4	14166170	60.04/01	10	14327101	90.01/02	8	15540221	70.03/01	12
13311011	70.04/01	3	"	90.01/08	32	"	90.02/02	8	"	70.07/01	14
13400575	70.04/01	40	"	90.03/02	4	14328101	10.02/01	2	15540321	10.07/01	17
13401476	90.01/01	7	14166370	60.04/01	15	"	10.03/01	9	"	50.05/02	19
"	90.02/01	17	14166570	60.04/01	14	14328301	10.03/02	8	"	70.03/01	2
13406711	90.01/08	6	14166770	60.05/01	13	14328501	10.01/01	11	15540521	50.02/01	18
13407211	40.04/01	12	14196670	10.03/02	24	14330260	10.08/01	15	"	50.03/01	7
"	50.03/01	4	14198810	50.01/01	29	14452780	30.01/02	2	15540621	50.05/02	4
"	60.05/01	5	"	90.02/08	26	"	90.02/07	18	15540630	50.05/04	4
"	90.02/05	2	14198910	50.01/01	19	14452980	90.02/04	4	15540721	30.01/01	6
"	90.03/02	9	14199110	50.01/01	26	"	90.02/07	9	15541521	50.01/01	37
13407811	50.03/01	3	14233221	10.06/03	11	"	90.02/08	5	15835221	50.02/01	9
"	50.04/01	25	"	50.05/02	13	14457080	90.01/06	5	15836421	70.06/02	8
"	90.01/04	10	"	50.05/02	20	"	90.05/01	14	"	90.02/05	8
13408411	50.01/01	11	14233421	30.05/01	17	14457180	90.01/01	10	15840521	30.01/01	36
"	60.01/01	2	14234421	30.05/01	18	"	90.01/06	20	15864421	40.07/02	8
13413290	30.01/01	21	14238021	10.06/03	14	"	90.02/01	3	15888721	10.07/02	8
13449910	10.07/02	28	"	40.07/01	24	14457280	90.01/01	1	"	10.07/06	7
13450320	90.01/06	25	"	40.07/02	20	"	90.02/01	7	"	90.01/06	15
13516221	10.01/01	17	"	50.05/03	7	"	90.02/07	10	15888821	10.01/03	14
"	10.03/02	14	"	50.05/04	5	14457480	90.01/06	4	"	10.06/01	10
13516920	10.06/01	26	14251621	30.05/01	15	14458680	10.06/01	20	"	90.02/01	8
13517010	30.02/01	7	14254121	50.05/02	1	14458780	80.04/03	2	15896211	70.02/01	17
13517630	10.06/02	20	"	50.05/02	27	14459280	90.01/06	38	"	70.04/01	20
13517720	10.01/03	13	14254421	30.05/01	9	14461180	30.02/01	15	"	80.04/03	13
13543710	10.08/02	10	14254530	50.01/01	36	14461280	30.02/01	9	"	80.05/01	9
13550201	80.04/04	31	14255030	50.01/01	38	14462880	90.05/01	19	"	80.05/02	24
13550401	70.04/01	24	14282370	10.01/01	24	14462882	10.07/02	2	"	90.02/08	8
13748610	10.07/04	4	14282470	10.01/01	25	14463080	90.01/06	13	15896411	70.04/01	19
13868350	20.05/01	25	14282770	10.01/01	9	14463880	90.05/01	7	"	80.04/01	22
13979611	70.02/01	2	14282970	10.01/01	22	14464580	90.02/01	23	"	80.04/03	16
14045271	30.02/01	12	14323311	30.01/01	25	14471180	90.01/05	22	"	80.05/02	27
"	30.06/01	7	14323911	10.01/01	13	14471280	90.01/05	15	"	80.05/02	31
14048211	30.02/01	6	"	10.01/01	23	14472680	90.01/05	7	15900121	90.04/02	13
14048222	60.04/02	8	14324201	30.06/02	26	14543170	90.01/08	7	15919401	60.07/01	1
14142390	70.04/01	46	14324211	10.01/01	16	14575780	70.04/01	31	15970321	70.04/01	33
14147590	80.05/03	4	14324401	30.06/02	12	14580771	91.01/02	3	"	90.01/05	17

N. ORDINAZIONE	SGR	FIG	N. ORDINAZIONE	SGR	FIG	N. ORDINAZIONE	SGR	FIG	N. ORDINAZIONE	SGR	FIG
15970421	70.06/02	10	16043221	30.01/01	22	16043921	30.01/01	14	20045200	30.02/01	26
15970521	10.06/01	31	"	30.04/01	6	"	90.01/02	5	"	30.06/01	10
"	30.01/01	2	"	30.06/02	11	"	90.02/02	5	"	30.06/02	19
"	30.05/01	4	"	60.08/01	10	16044021	10.05/01	1	20063390	60.04/01	3
"	60.06/01	18	"	70.02/01	11	"	10.05/03	15	20063490	90.01/06	36
"	70.04/01	26	"	70.03/01	16	"	60.04/02	17	20063500	90.02/07	12
"	70.05/02	8	"	70.04/01	22	"	80.04/01	19	20229990	40.07/01	14
"	70.06/01	2	"	90.01/04	1	"	90.02/01	20	20685450	30.06/01	1
"	70.06/02	1	"	90.01/08	14	16044121	90.01/01	21	20705250	30.02/01	21
"	70.07/01	4	"	90.01/09	3	16044221	10.01/03	1	"	30.06/01	21
"	90.01/07	7	16043321	10.01/02	6	"	10.05/03	16	20943310	40.07/01	1
"	90.02/08	27	"	30.01/01	15	16044321	10.05/01	5	23111990	30.06/02	16
15970621	70.05/01	5	16043421	10.01/02	15	"	90.02/01	12	24900510	40.07/01	16
15970721	10.07/02	25	"	10.01/03	4	16044421	90.02/07	5	24940210	30.05/01	14
"	30.01/01	18	"	10.03/02	5	16044521	10.03/02	13	24941470	50.05/03	3
"	40.04/01	18	"	10.07/02	4	"	90.01/02	13	"	50.05/04	8
"	50.01/01	14	"	10.07/05	5	"	90.02/02	13	24974160	30.06/01	4
"	50.05/02	15	"	10.08/02	2	16044621	10.01/03	7	26797140	30.06/02	20
"	60.04/01	13	"	50.04/01	14	16044921	10.05/01	12	26800000	40.07/01	10
"	70.03/01	18	"	60.04/02	14	16045621	10.05/01	15	"	40.07/02	9
"	70.05/02	4	"	80.01/03	17	16100811	10.01/03	6	26800130	40.07/01	12
"	70.06/01	12	"	80.05/01	5	"	10.03/02	12	"	40.07/02	10
"	70.07/01	10	"	90.03/02	7	"	10.06/01	22	26800150	30.05/01	8
"	80.05/02	17	16043521	30.06/01	16	"	10.06/02	11	26800360	40.07/02	11
"	90.01/09	14	16043621	10.01/03	19	"	10.08/01	12	26801280	90.03/02	14
"	90.02/04	15	"	10.05/01	21	"	60.04/02	2	28041260	30.06/02	18
"	90.05/02	7	"	10.07/02	18	"	70.02/01	12	28041610	30.04/01	11
15970921	10.07/02	10	"	10.08/03	12	"	80.01/03	19	28041620	30.02/01	18
"	10.08/04	14	"	10.08/04	16	"	80.05/01	4	28043280	10.02/01	12
"	80.05/02	6	"	30.01/02	7	16100821	10.01/02	19	28044380	60.01/01	25
"	90.01/08	13	"	90.01/06	26	"	10.06/02	17	28995870	30.02/01	3
15971321	80.01/01	18	"	90.02/04	7	"	90.02/01	14	28996320	30.02/01	14
"	90.01/08	26	"	90.02/07	7	16100840	10.08/03	10	40000011	10.01/03	9
15971721	90.05/01	5	16043821	10.01/02	21	"	10.08/04	8	40000371	30.05/01	7
15973821	90.05/02	11	"	10.08/01	7	16102311	60.06/01	3	40000520	50.04/02	1
15981031	50.01/01	16	"	10.08/02	8	"	90.01/08	21	40000720	10.01/02	20
15981231	50.01/01	17	"	10.08/04	10	"	90.01/09	6	44015841	90.01/01	11
15990121	90.04/01	11	"	60.04/02	12	16103611	50.01/01	31	44017955	70.04/01	43
16043021	90.02/08	23	"	80.01/02	7	16104111	10.01/01	18	44900813	10.08/04	15
16043121	50.05/01	1	"	90.01/01	13	"	60.07/01	4	44900845	80.05/01	14
16043221	10.01/01	1	"	90.01/02	16	"	80.01/02	5	44900848	70.02/01	1
"	10.06/01	29	"	90.02/02	16	19053182	10.08/01	4	44900851	70.02/01	8

PARTI DI RICAMBIO

PIÈCES DÉTACHÉES

SPARE PARTS

ERSATZTEILE

PIEZAS DE REPUESTO

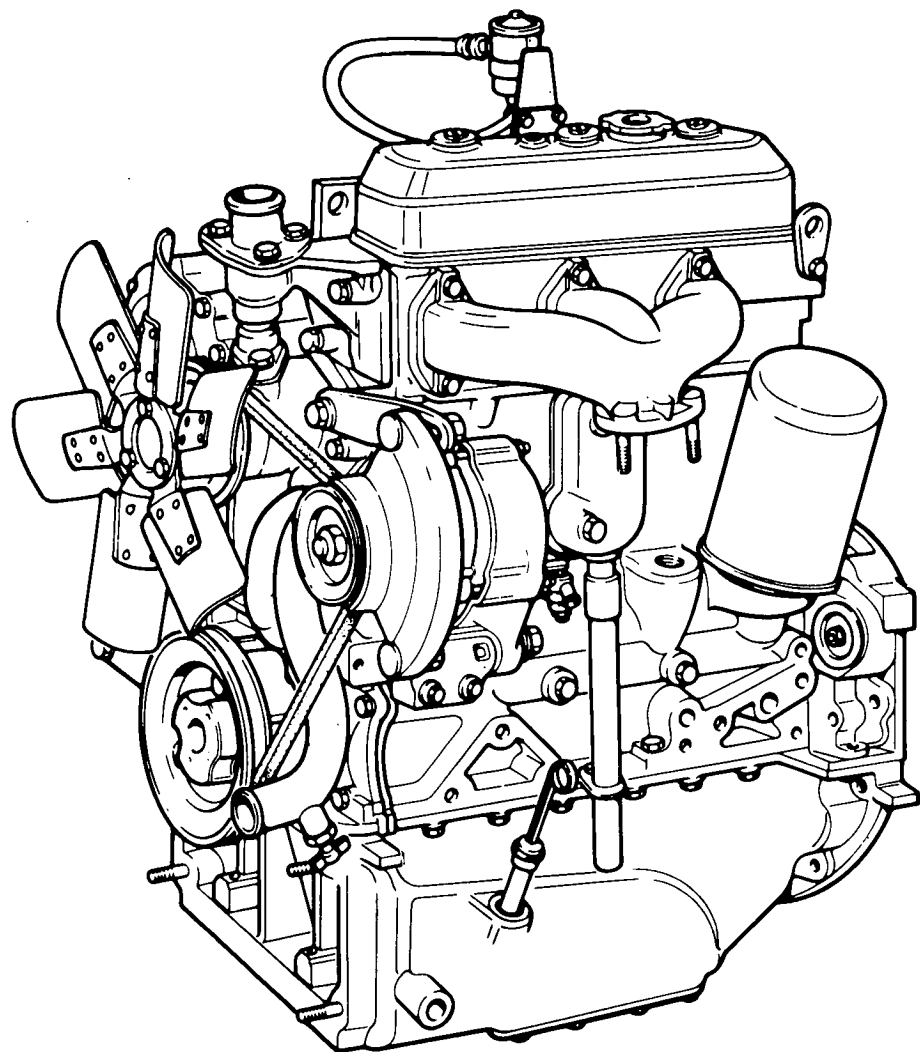

BASAMENTO E TESTA CILINDRI

Bâti et culasse
Kurbelgehäuse und Zylinderkopf

Crankcase and Cylinder Head
Bloque de cilindros y culata

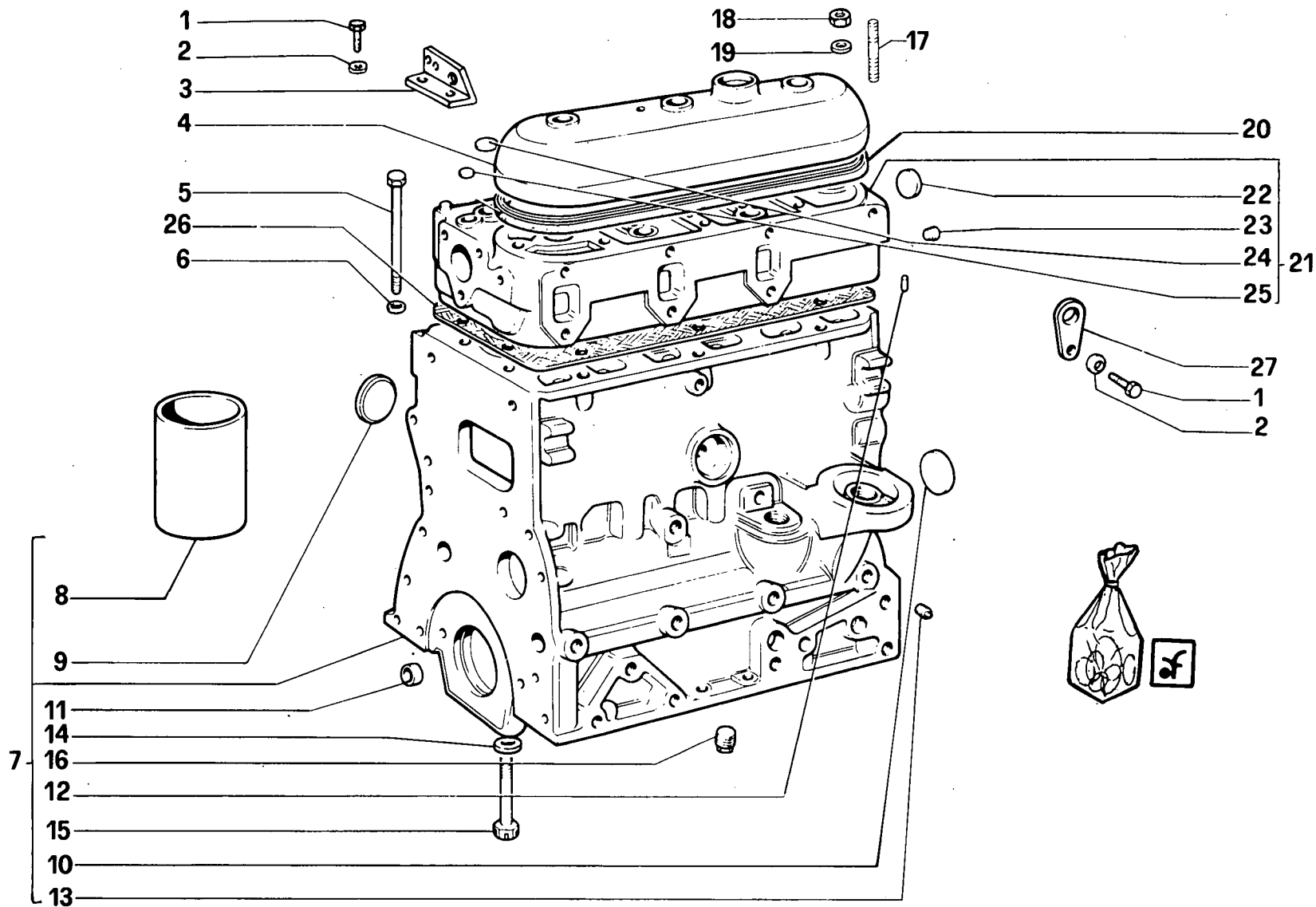

C80/50

BASAMENTO E TESTA CILINDRI

10.01/01

(09-1981)

FIG	N. ORDINAZIONE	QTA	DENOMINAZIONE	DESIGNATION	BENENNUNG	DESCRIPTION	DENOMINAZIONES
	1909579	SN	SERIE GUARNIZIONI MOTORE	POCHET. JOINTS DU MOTEUR	MOTORDICHTUNGENSE- RIE	SET OF ENGINE GASKETS	SERIE GUARNICION MOTOR
	1909580	SN	SERIE RETTIFICA VALVOLE	POCH. RECTIFIC. SOUPAPES	VENTILBERICHTIG. SERIE	SERIE/VALVE AMENDMENTS	SERIE RECTIFICA VALVULAS
1	16043221	3	VITE	VIS	SCHRAUBE	SCREW	TORNILLO
2	11198071	3	ROSETTA DI SICUREZZA	RONDELLE FREIN	SICHERUNGSRING	LOCKWASHER	ARANDELA DE FRENO
3	4609391	1	OCCHIELLO	OEIL	OESE	EYE	OJO
4	4654360	1	COPERCHIO	COUVERCLE	DECKEL	COVER	TAPA
5	4601061	14	VITE	VIS	SCHRAUBE	SCREW	TORNILLO
6	4585990	14	ROSETTA DI SICUREZZA	RONDELLE FREIN	SICHERUNGSRING	LOCKWASHER	ARANDELA DE FRENO
7	4713391	1	BASAMENTO	BATI	KURBELGEHAUSE	CRANKCASE	BLOQUE
8	4653280	3	CANNA CILINDRO	CHEMISE DE CYLINDRE	ZYLINDERROHR	CYLINDER LINER	CAMISA CILINDRO
8	4653281	-	CANNA CILINDRO +0,2	CHEMISE DE CYLINDRE	ZYLINDERROHR	CYLINDER LINER	CAMISA CILINDRO
9	14282770	3	TAPPO	BOUCHON	STOPFEN	PLUG	TAPON
10	10160701	1	TAPPO	BOUCHON	STOPFEN	PLUG	TAPON
11	14328501	3	TAPPO	BOUCHON	STOPFEN	PLUG	TAPON
12	4599607	1	GRANO	ERGOT	PASSTIFT	DOWEL	PITON
13	14323911	4	TAPPO	BOUCHON	STOPFEN	PLUG	TAPON
14	4710518	8	ROSETTA PIANA	RONDELLE	SCHEIBE	WASHER	ARANDELA
15	4710517	8	VITE	VIS	SCHRAUBE	SCREW	TORNILLO
16	14324211	1	TAPPO	BOUCHON	STOPFEN	PLUG	TAPON
17	13516221	3	PRIGIONIERO	GOUJON	STIFTSCHRAUBE	STUD	ESPARRAGO
18	16104111	3	DADO	ECROU	MUTTER	NUT	TUERCA
19	10519660	3	GUARNIZIONE	GARNITURE	DICHTUNG	GASKET	JUNTA
20	4654361	1	GUARNIZIONE	GARNITURE	DICHTUNG	GASKET	JUNTA
21	4682985	1	TESTA CILINDRI	CULASSE	ZYLINDERKOPF	CYLINDER HEAD	CULATA
22	14282970	1	TAPPO	BOUCHON	STOPFEN	PLUG	TAPON
23	14323911	1	TAPPO	BOUCHON	STOPFEN	PLUG	TAPON
24	14282370	1	TAPPO	BOUCHON	STOPFEN	PLUG	TAPON
25	14282470	6	TAPPO	BOUCHON	STOPFEN	PLUG	TAPON
26	4690375	1	GUARNIZIONE TESTA	GARNITURE	DICHTUNG	GASKET	JUNTA
27	4628797	1	OCCHIELLO POST.	OEIL	OESE	EYE	OJO

COPPA E COPERCHI BASAMENTO

Carter d'huile et couvercles de bâti
Ölwanne und Deckel des Kurbelgehäuses

Oil Sump and Crankcase Covers
Cárter de aceite y tapas del bloque

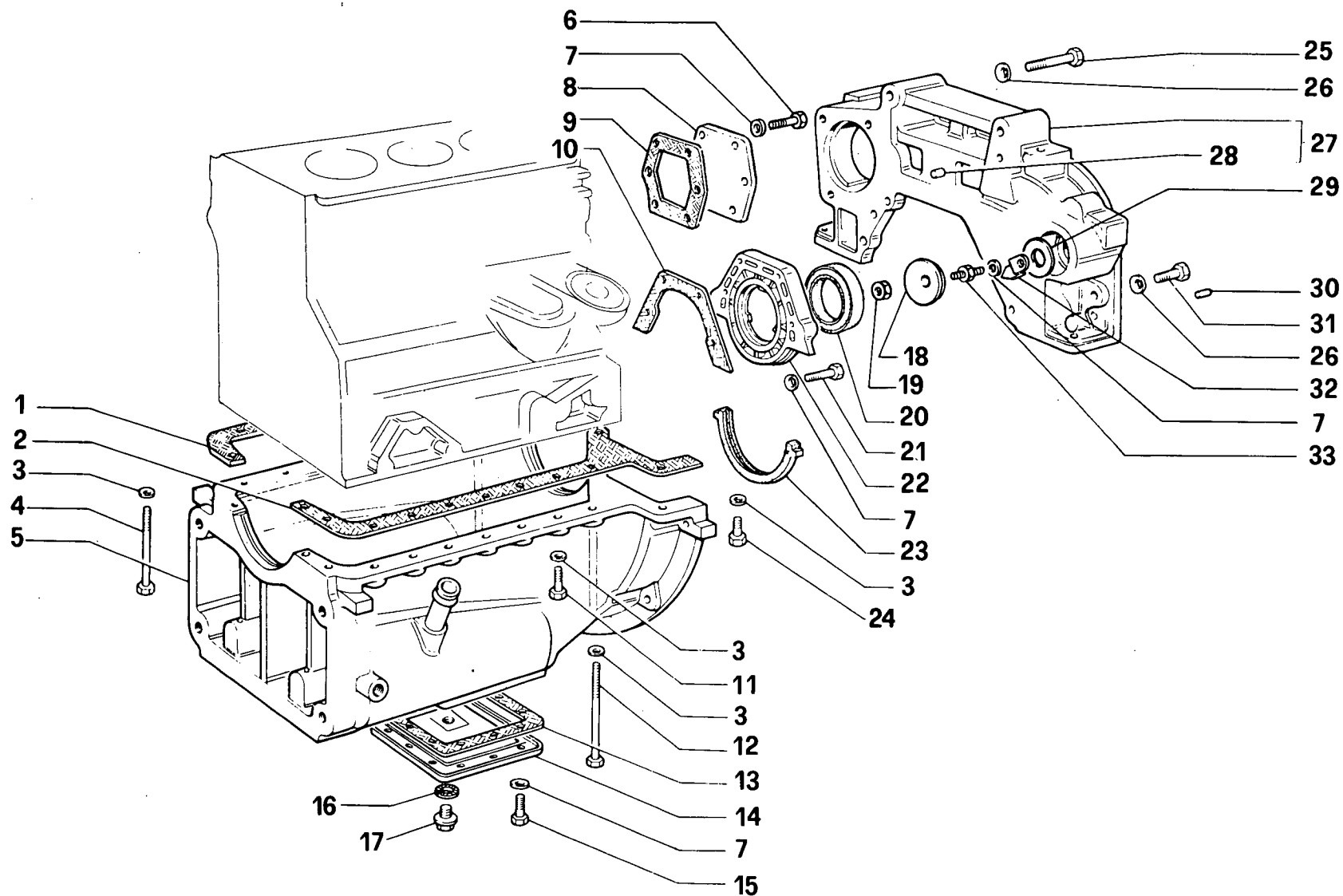

C80/50

COPPA E COPERCHI BASAMENTO

10.01/02

(09-1981)

FIG	N. ORDINAZIONE	QTA	DENOMINAZIONE	DESIGNATION	BENENNUNG	DESCRIPTION	DENOMINACIONES
1	4602069	1	GUARNIZIONE DX	GARNITURE	DICHTUNG	GASKET	JUNTA
2	4602068	1	GUARNIZIONE SX	GARNITURE	DICHTUNG	GASKET	JUNTA
3	11198371	21	ROSETTA DI SICUREZZA	RONDELLE FREIN	SICHERUNGSRING	LOCKWASHER	ARANDELA DE FRENO
4	4607933	3	VITE	VIS	SCHRAUBE	SCREW	TORNILLO
5	4609709	1	COPPA OLIO COMPL.	CARTER A HUILE	OELWANNE	OIL SUMP	CARTER DE ACEITE
6	16043321	12	VITE	VIS	SCHRAUBE	SCREW	TORNILLO
7	11198071	12	ROSETTA DI SICUREZZA	RONDELLE FREIN	SICHERUNGSRING	LOCKWASHER	ARANDELA DE FRENO
8	4653282	1	COPERCHIO	COUVERCLE	DECKEL	COVER	TAPA
9	4653283	1	GUARNIZIONE	GARNITURE	DICHTUNG	GASKET	JUNTA
10	4657434	1	GUARNIZIONE	GARNITURE	DICHTUNG	GASKET	JUNTA
11	11307021	14	VITE	VIS	SCHRAUBE	SCREW	TORNILLO
12	4607934	2	VITE	VIS	SCHRAUBE	SCREW	TORNILLO
13	4602067	1	GUARNIZIONE	GARNITURE	DICHTUNG	GASKET	JUNTA
14	4660759	1	COPERCHIO	COUVERCLE	DECKEL	COVER	TAPA
15	16043421	6	VITE	VIS	SCHRAUBE	SCREW	TORNILLO
16	10263460	1	GUARNIZIONE DI TENUTA	JOINT	DICHTUNG	GASKET	JUNTA
17	10305171	1	TAPPO	BOUCHON	STOPFEN	PLUG	TAPON
18	4670802	1	COPERCHIO	COUVERCLE	DECKEL	COVER	TAPA
19	16100821	1	DADO	ECROU	MUTTER	NUT	TUERCA
20	40000720	1	ANELLO DI TENUTA	BAGUE	RING	RING	ANILLO
21	16043821	4	VITE	VIS	SCHRAUBE	SCREW	TORNILLO
22	4656176	1	COPERCHIO	COUVERCLE	DECKEL	COVER	TAPA
23	4600753	1	GUARNIZIONE	GARNITURE	DICHTUNG	GASKET	JUNTA
24	11306921	2	VITE	VIS	SCHRAUBE	SCREW	TORNILLO
25	11360221	2	VITE	VIS	SCHRAUBE	SCREW	TORNILLO
26	10125171	4	ROSETTA DI SICUREZZA	RONDELLE FREIN	SICHERUNGSRING	LOCKWASHER	ARANDELA DE FRENO
27	4654391	1	SUPPORTO	SUPPORT	LAGER	SUPPORT	SOPORTE
28	10839710	2	SPINA	GOUPILLE	STIFT	PIN	PASADOR
29	4622851	1	GUARNIZIONE	GARNITURE	DICHTUNG	GASKET	JUNTA
30	4658441	2	SPINA	GOUPILLE	STIFT	PIN	PASADOR
31	11408321	2	VITE	VIS	SCHRAUBE	SCREW	TORNILLO
32	4607466	1	INDICE MESSA IN FASE	INDEX DE CALAGE	EINSTELLZEIGER	TIMING REF/INDEX	INDICE DE REGLAJE
33	12430121	1	PRIGIONIERO	GOUJON	STIFTSCHRAUBE	STUD	ESPARRAGO

CB0.50

01 02 03

COPPA E COPERCHI BASAMENTO

Cartier d'huile et couvercles de bâti
Ölwanne und Deckel des Kurbelgehäuses

Oil Sump and Crankcase Covers
Cárter de aceite y tapas del bloque

10.1/3

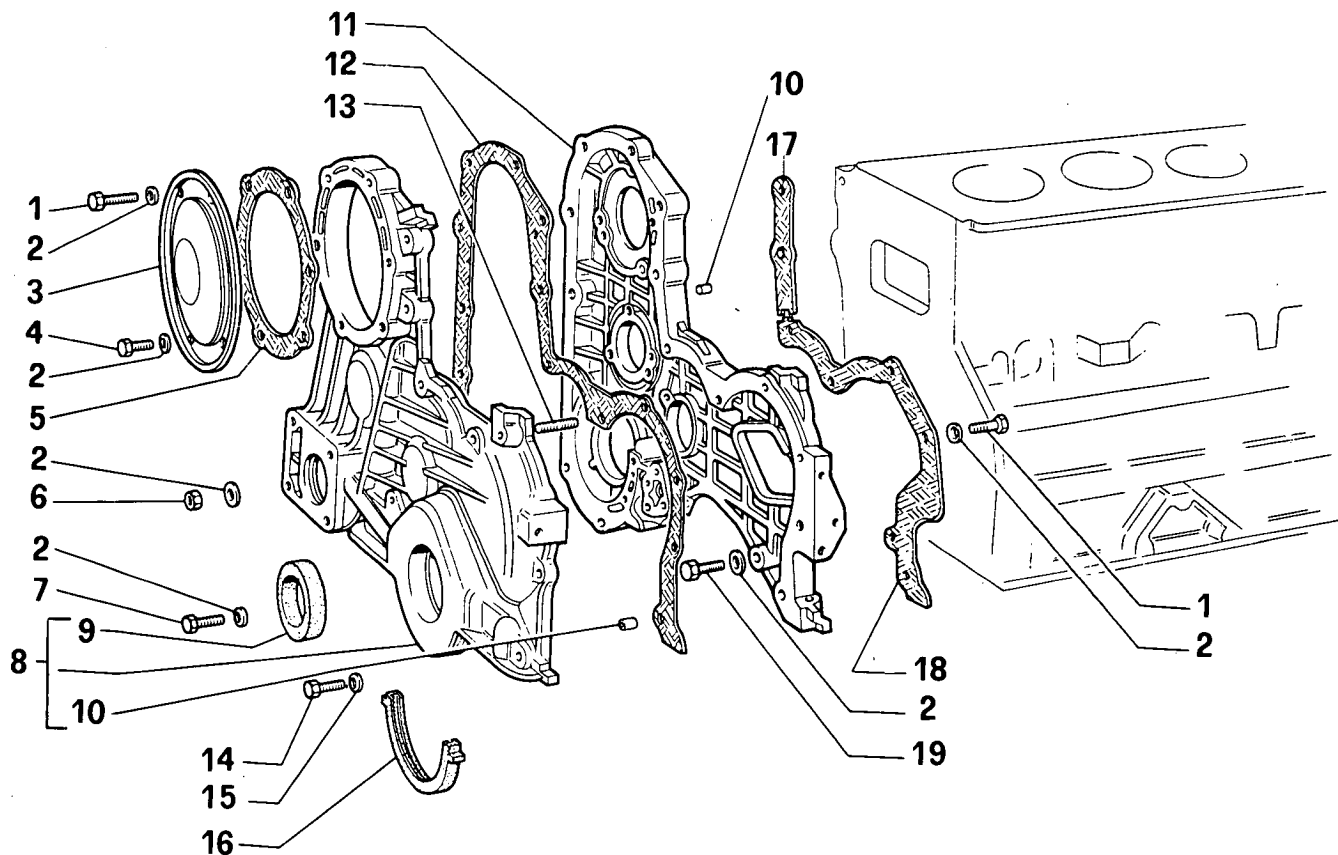

C80/50

COPPA E COPERCHI BASAMENTO

10.01/03

(09-1981)

FIG	N. ORDINAZIONE	QTA	DENOMINAZIONE	DESIGNATION	BENENNUNG	DESCRIPTION	DENOMINACIONES
1	16044221	4	VITE	VIS	SCHRAUBE	SCREW	TORNILLO
2	11198071	21	ROSETTA DI SICUREZZA	RONDELLE FREIN	SICHERUNGSRING	LOCKWASHER	ARANDELA DE FRENO
3	4600632	1	COPERCHIO	COUVERCLE	DECKEL	COVER	TAPA
4	16043421	2	VITE	VIS	SCHRAUBE	SCREW	TORNILLO
5	4600633	1	GUARNIZIONE	GARNITURE	DICHTUNG	GASKET	JUNTA
6	16100811	2	DADO	ECROU	MUTTER	NUT	TUERCA
7	16044621	1	VITE	VIS	SCHRAUBE	SCREW	TORNILLO
8	4621730	1	COPERCHIO ANT.	COUVERCLE	DECKEL	COVER	TAPA
9	40000011	1	ANELLO DI TENUTA	BAGUE	RING	RING	ANILLO
10	10839610	2	SPINA	GOUPILLE	STIFT	PIN	PASADOR
11	4659056	1	SCATOLA	CARTER	GEHAUSE	CASE	CAJA
12	4607641	1	GUARNIZIONE	GARNITURE	DICHTUNG	GASKET	JUNTA
13	13517720	1	PRIGIONIERO	GOUJON	STIFTSCHRAUBE	STUD	ESPARRAGO
14	15888821	1	VITE	VIS	SCHRAUBE	SCREW	TORNILLO
15	11198371	1	ROSETTA DI SICUREZZA	RONDELLE FREIN	SICHERUNGSRING	LOCKWASHER	ARANDELA DE FRENO
16	4031577	1	GUARNIZIONE	GARNITURE	DICHTUNG	GASKET	JUNTA
17	4607643	1	GUARNIZIONE SUP.	GARNITURE	DICHTUNG	GASKET	JUNTA
18	4607639	1	GUARNIZIONE INF.	GARNITURE	DICHTUNG	GASKET	JUNTA
19	16043621	4	VITE	VIS	SCHRAUBE	SCREW	TORNILLO

CEB 50

01 02 03

ALBERO E VOLANO MOTORE

Vilebrequin et volant moteur
Kurbelwelle und Schwungrad

Crankshaft and Flywheel
Cigüeñal y volante

10.2/1

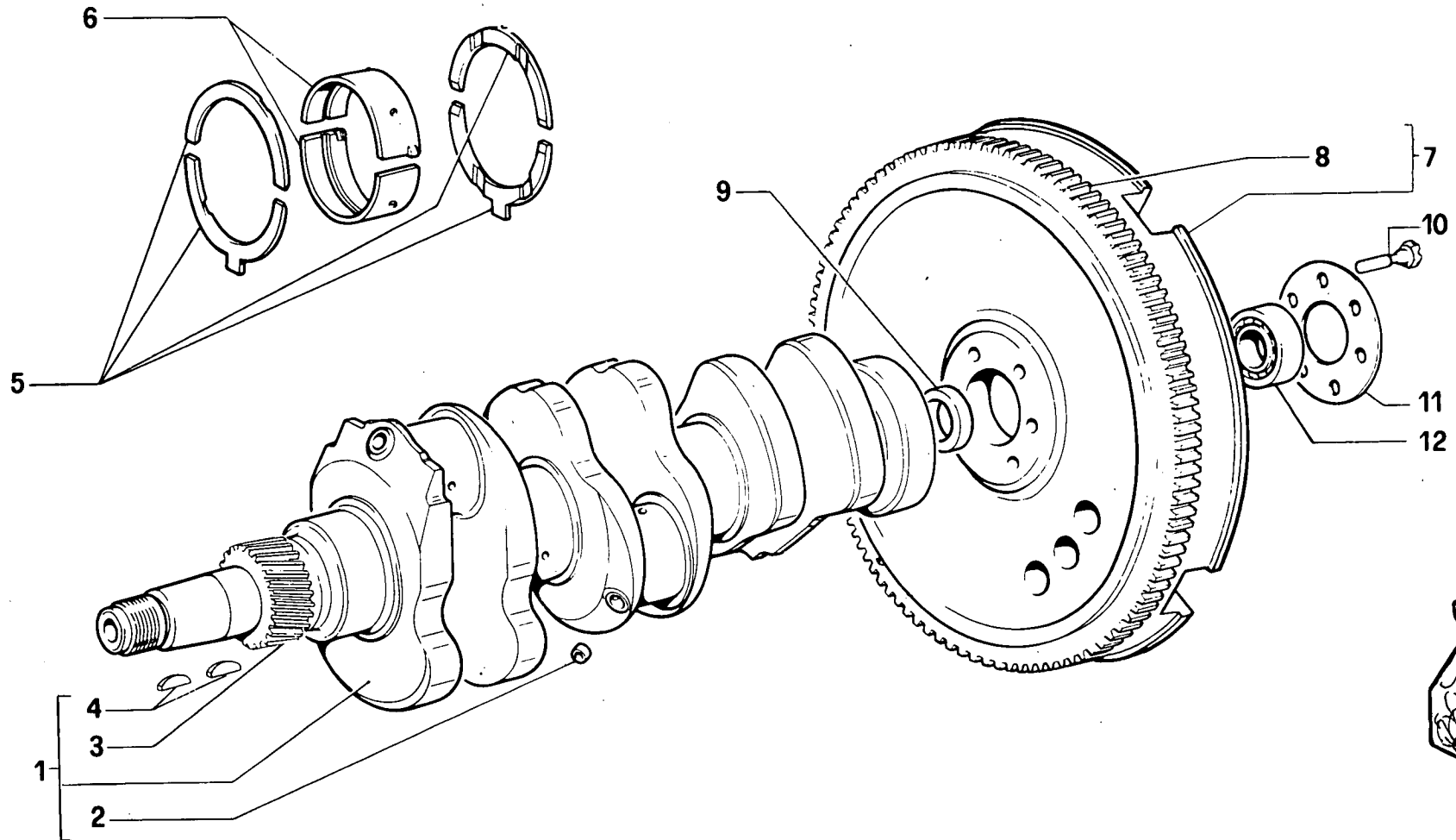

C80/50

ALBERO E VOLANO MOTORE

10.02/01

(09-1981)

FIG	N. ORDINAZIONE	QTA	DENOMINAZIONE	DESIGNATION	BENENNUNG	DESCRIPTION	DENOMINACIONES
1	4738369	1	ALBERO MOTORE COMPLETO	VILEBREQUIN	KURBELWELLE	CRANKSHAFT	CIGUENAL
2	14328101	3	TAPPO	BOUCHON	STOPFEN	PLUG	TAPON
3	4607764	1	INGRANAGGIO CONDUTTORE	PIGNON CONDUCTEUR	TREIBENDES ZAHNRAD	DRIVING GEAR	PINON CONDUCTOR
4	4606664	2	LINGUETTA	LINGUET	SCHEIBENFEDER	KEY	CHAVETA
5	1909499	1	SERIE SEMIANELLI	POCHET DEMI-BAGUES	RINGHAELFESERIE	SET OF HALF RINGS	SERIE SEMIANILLOS
5	1909500	-	SERIE SEMIANELLI +0,127	POCHET DEMI-BAGUES	RINGHAELFESERIE	SET OF HALF RINGS	SERIE SEMIANILLOS
6	1909638	4	SERIE SEMICUSCINETTI	POCHET. DEMI-COUS- SINETS	SCHALENHAELFTESERIE	SET OF HALF-BEA- RINGS	SERIE SEMICOJENETES
6	1909639	-	SERIE SEMICUSCIN. -0.254	POCHET. DEMI- COUSSINETS	SCHALENHAELFTESERIE	SET OF HALF- BEARINGS	SERIE SEMICOJENETES
6	1909640	-	SERIE SEMICUSCIN. -0.508	POCHET. DEMI- COUSSINETS	SCHALENHAELFTESERIE	SET OF HALF- BEARINGS	SERIE SEMICOJENETES
6	1909641	-	SERIE SEMICUSCIN. -0.762	POCHET. DEMI- COUSSINETS	SCHALENHAELFTESERIE	SET OF HALF- BEARINGS	SERIE SEMICOJENETES
6	1909642	-	SERIE SEMICUSCIN. -1.016	POCHET. DEMI- COUSSINETS	SCHALENHAELFTESERIE	SET OF HALF- BEARINGS	SERIE SEMICOJENETES
7	4737534	1	VOLANO MOTORE COMPL.	VOLANT DU MOTEUR	SCHWUNGRAD	FLYWHEEL	VOLANTE DEL MOTOR
8	4988553	1	CORONA DENT. AVVIAMENTO	COURONNE DEMARREUR	ANLASSERZAHNKRANZ	STARTER RING GEAR	CORONA ARRANQUE
9	4602601	1	DISTANZIALE	ENTRETOISE	ABSTANDSTUECK	SPACER	SEPARADOR
10	4652837	6	VITE	VIS	SCHRAUBE	SCREW	TORNILLO
11	4676518	1	ROSETTA PIANA	RONDELLE	SCHEIBE	WASHER	ARANDELA
12	28043280	1	CUSCINETTO	ROULEMENT	LAGER	BEARING	RODAMIENTO

BIELLE E STANTUFFI

Bielles et pistons
Pleuelstangen und Kolben

Connecting Rods and Pistons
Bielas y émbolos

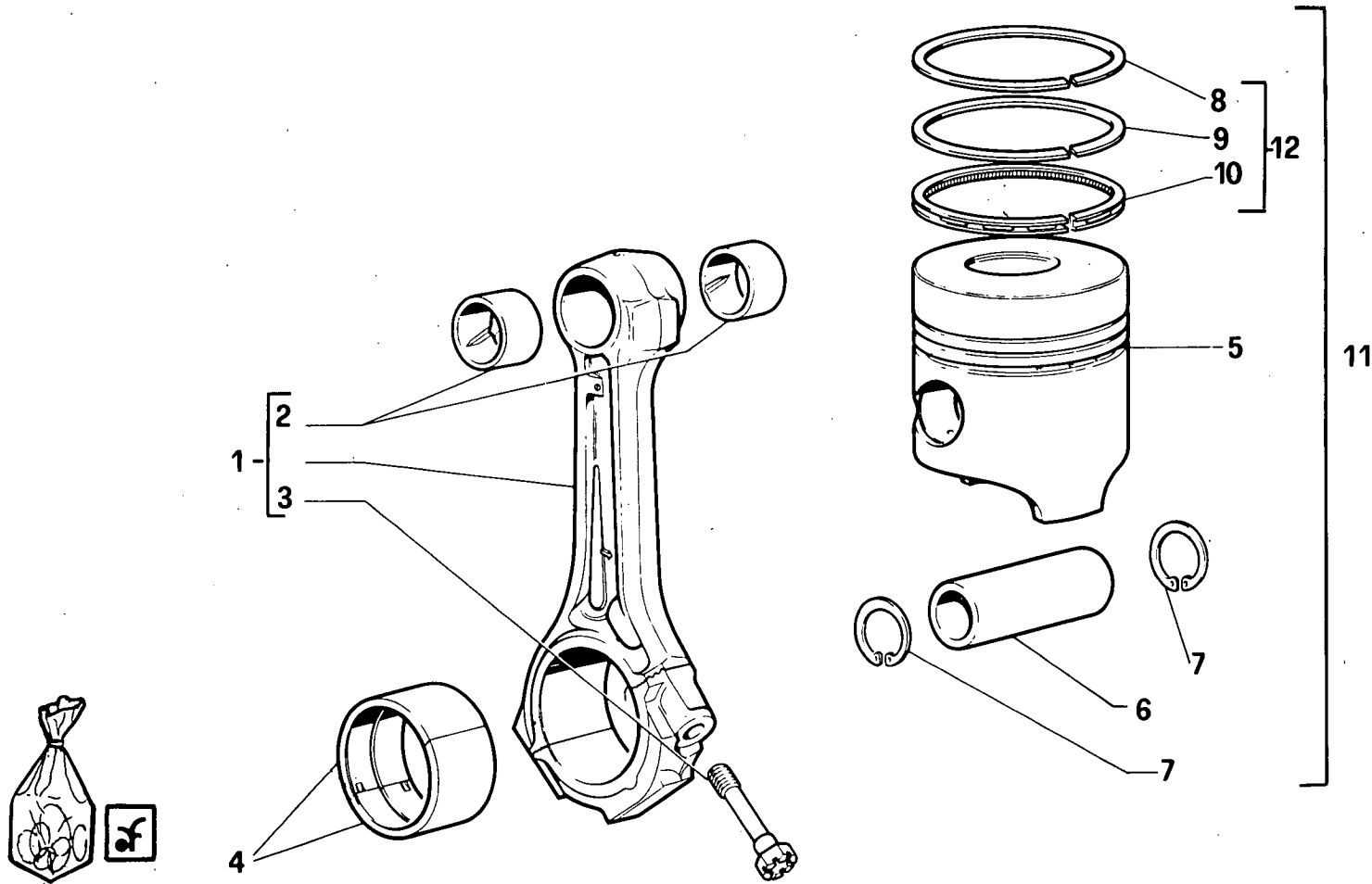

C80/50

BIELLE E STANTUFFI

10.02/02

(09-1981)

FIG	N. ORDINAZIONE	QTA	DENOMINAZIONE	DESIGNATION	BENENNUNG	DESCRIPTION	DENOMINACIONES
1	4763918	3	BIELLA COMPLETA	BIELLE	LASCHE	LINK	BIELA
2	4555699	2	BOCCOLA	DOUILLE	BUECHSE	BUSH	CASQUILLO
3	4700829	2	VITE	VIS	SCHRAUBE	SCREW	TORNILLO
4	1909643	3	SERIE SEMICUSCINETTI	POCHET. DEMI-COUS- SINETS	SCHALENHAEFTESERIE	SET OF HALF-BEA- RINGS	SERIE SEMICOJENETES
4	1909644	-	SERIE SEMICUSCIN. -0.254	POCHET. DEMI- COUSSINETS	SCHALENHAEFTESERIE	SET OF HALF- BEARINGS	SERIE SEMICOJENETES
4	1909645	-	SERIE SEMICUSCIN. -0.508	POCHET. DEMI- COUSSINETS	SCHALENHAEFTESERIE	SET OF HALF- BEARINGS	SERIE SEMICOJENETES
4	1909646	-	SERIE SEMICUSCIN. -0.762	POCHET. DEMI- COUSSINETS	SCHALENHAEFTESERIE	SET OF HALF- BEARINGS	SERIE SEMICOJENETES
4	1909647	-	SERIE SEMICUSCIN. -1.016	POCHET. DEMI- COUSSINETS	SCHALENHAEFTESERIE	SET OF HALF- BEARINGS	SERIE SEMICOJENETES
5	4712886	3	STANTUFFO	PISTON	KOLBEN	PISTON	EMBOLO
5	4712888	-	STANTUFFO +0.2	PISTON	KOLBEN	PISTON	EMBOLO
5	4712889	-	STANTUFFO +0.4	PISTON	KOLBEN	PISTON	EMBOLO
5	4712890	-	STANTUFFO +0.6	PISTON	KOLBEN	PISTON	EMBOLO
5	4712891	-	STANTUFFO +0.8	PISTON	KOLBEN	PISTON	EMBOLO
6	4663606	3	PERNO DELLO STANTUFFO	AXE DE PISTON	KOLBENBOLZEN	PISTON PIN	BULON DEL EMBOLO
6	4663607	-	PERNO STANTUFFO +0.2	AXE DE PISTON	KOLBENBOLZEN	PISTON PIN	BULON DEL EMBOLO
7	11059076	6	ANELLO DI SICUREZZA	ARRETOIR	SICHERUNGSRING	LOCKRING	ANILLO DE FRENO
8	4653308	3	ANELLO STANTUFFO CROMATO	SEGMENT	KOLBENRING	PISTON RING	ARO DE ENBOLO
8	4653310	-	ANELLO STANTUFFO + 0.2 CROMATO	SEGMENT	KOLBENRING	PISTON RING	ARO DE EMBOLO
8	4653311	-	ANELLO STANTUFFO + 0.4 CROMATO	SEGMENT	KOLBENRING	PISTON RING	ARO DE EMBOLO
8	4653312	-	ANELLO STANTUFFO + 0.6 CROMATO	SEGMENT	KOLBENRING	PISTON RING	ARO DE EMBOLO
8	4653313	-	ANELLO STANTUFFO + 0.8 CROMATO	SEGMENT	KOLBENRING	PISTON RING	ARO DE EMBOLO
9	4653321	3	ANELLO RASCHIAOLIO	SEGMENT RACLEUR	OELABSTREIFRING	OIL SCRAPER RING	ARO DE ENGRASE
9	4653323	-	ANELLO RASCHIAOLIO + 0.2	SEGMENT RACLEUR	DELABST REIFRING	OIL SCRAPER RING	ARO DE ENGRASE

BIELLE E STANTUFFI

Bielles et pistons
Pleuelstangen und Kolben

Connecting Rods and Pistons
Bielas y émbolos

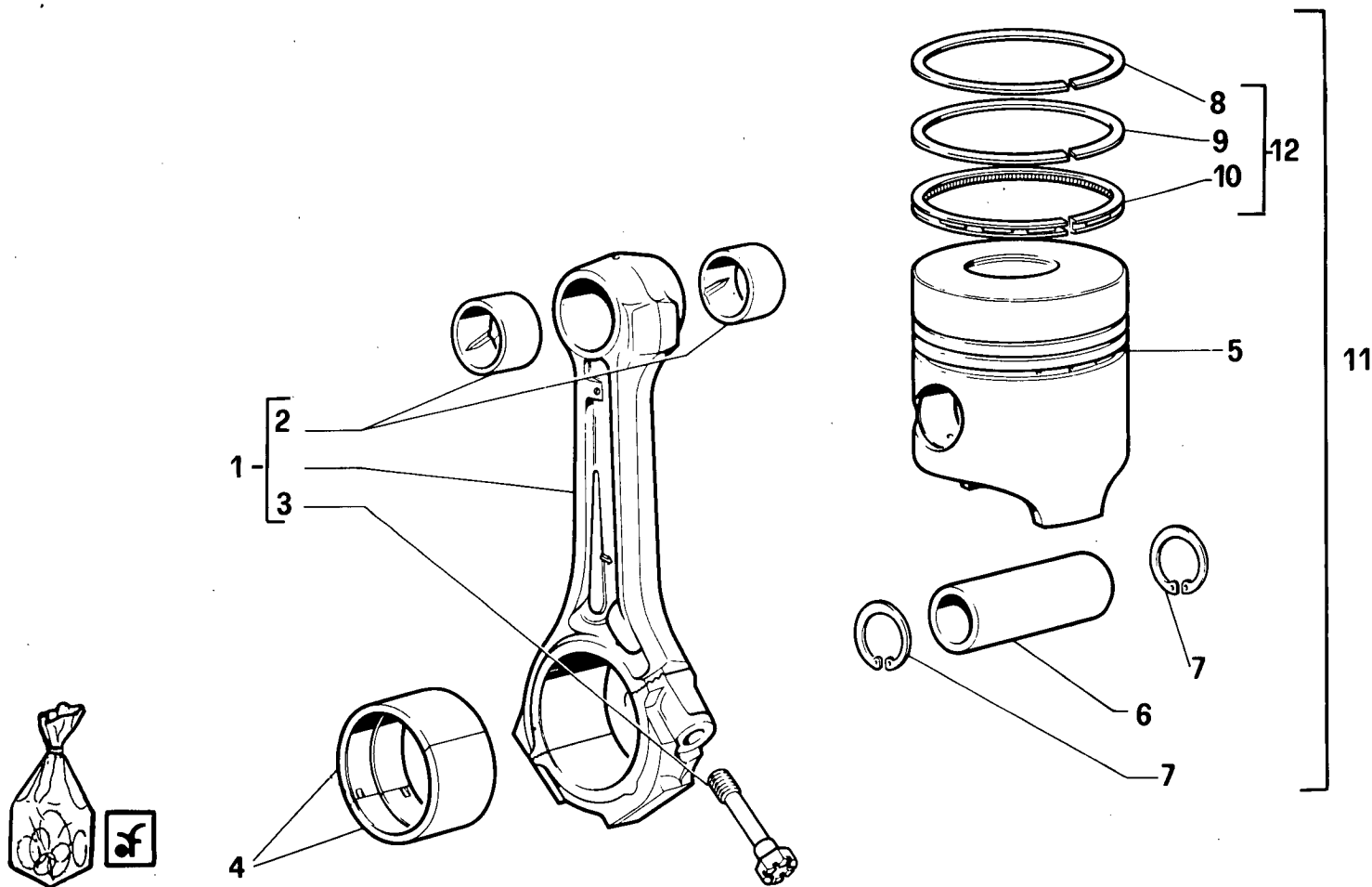

C80/50

BIELLE E STANTUFFI

10.02/02

(09-1981)

FIG	N. ORDINAZIONE	QTA	DENOMINAZIONE	DESIGNATION	BENENNUNG	DESCRIPTION	DENOMINACIONES
9	4653324	-	ANELLO RASCHIAOLIO + 0.4	SEGMENT RACLEUR	DELABSR REIFRING	OIL SCRAPER RING	ARO DE ENGRASE
9	4653325	-	ANELLO RASCHIAOLIO + 0.6	SEGMENT RACLEUR	DELABST REIFRING	OIL SCRAPER RING	ARO DE ENGRASE
9	4653326	-	ANELLO RASCHIAOLIO + 0.8	SEGMENT RACLEUR	DELABST REIFRING	OIL SCRAPER RING	ARO DE ENGRASE
10	4653314	3	ANELLO RASCHIAOLIO A FERITOIA	SEGMENT RACLEUR	OELABSTREIFRING	OIL SCRAPER RING	ARO DE ENGRASE
10	4653316	-	ANELLO RASCHIAOLIO + 0.2 A FERITOIA	SEGMENT RACLEUR	DELABST REIFRING	OIL SCRAPER RING	ARO DE ENGRASE
10	4653317	-	ANELLO RASCHIAOLIO + 0.4 A FERITOIA	SEGMENT RACLEUR	DELABSR REIFRING	OIL SCRAPER RING	ARO DE ENGRASE
10	4653318	-	ANELLO RASCHIAOLIO + 0.6 A FERITOIA	SEGMENT RACLEUR	DELABST REIFRING	OIL SCRAPER RING	ARO DE ENGRASE
10	4653319	-	ANELLO RASCHIAOLIO + 0.8 A FERITOIA	SEGMENT RACLEUR	DELABST REIFRING	OIL SCRAPER RING	ARO DE ENGRASE
11	1909207	3	STANTUFFO COMPLETO	PISTON COMPL	KOLBEN	COMPL. PISTON	EMBOLO COMPL.
11	1909214	-	STANTUFFO COMPLETO +0.2	PISTON COMPL.	KOLBEN	COMPL. PISTON	EMBOLO COMPL.
11	1909218	-	STANTUFFO COMPLETO +0.4	PISTON COMPL.	KOLBEN	COMPL. PISTON	EMBOLO COMPL.
11	1909222	-	STANTUFFO COMPLETO +0.6	PISTON COMPL.	KOLBEN	COMPL. PISTON	EMBOLO COMPL.
11	1909229	-	STANTUFFO COMPLETO +0.8	PISTON COMPL.	KOLBEN	COMPL. PISTON	EMBOLO COMPL.
12	1909172	3	SERIE ANELLI	POCHET. SEGMENTS	RINGSERIE	SET OF RINGS	SERIE ANILLO
12	1909173	-	SERIE ANELLI +0.2	POCHET. SEGMENTS	RINGSERIE	SET OF RINGS	SERIE ANILLO
12	1909174	-	SERIE ANELLI +0.4	POCHET. SEGMENTS	RINGSERIE	SET OF RINGS	SERIE ANILLO
12	1909175	-	SERIE ANELLI +0.6	POCHET. SEGMENTS	RINGSERIE	SET OF RINGS	SERIE ANILLO
12	1909176	-	SERIE ANELLI +0.8	POCHET. SEGMENTS	RINGSERIE	SET OF RINGS	SERIE ANILLO

COMANDO DISTRIBUZIONE

Commande de distribution
Steuerungsantrieb

Camshaft Drive
Piñones de la distribución

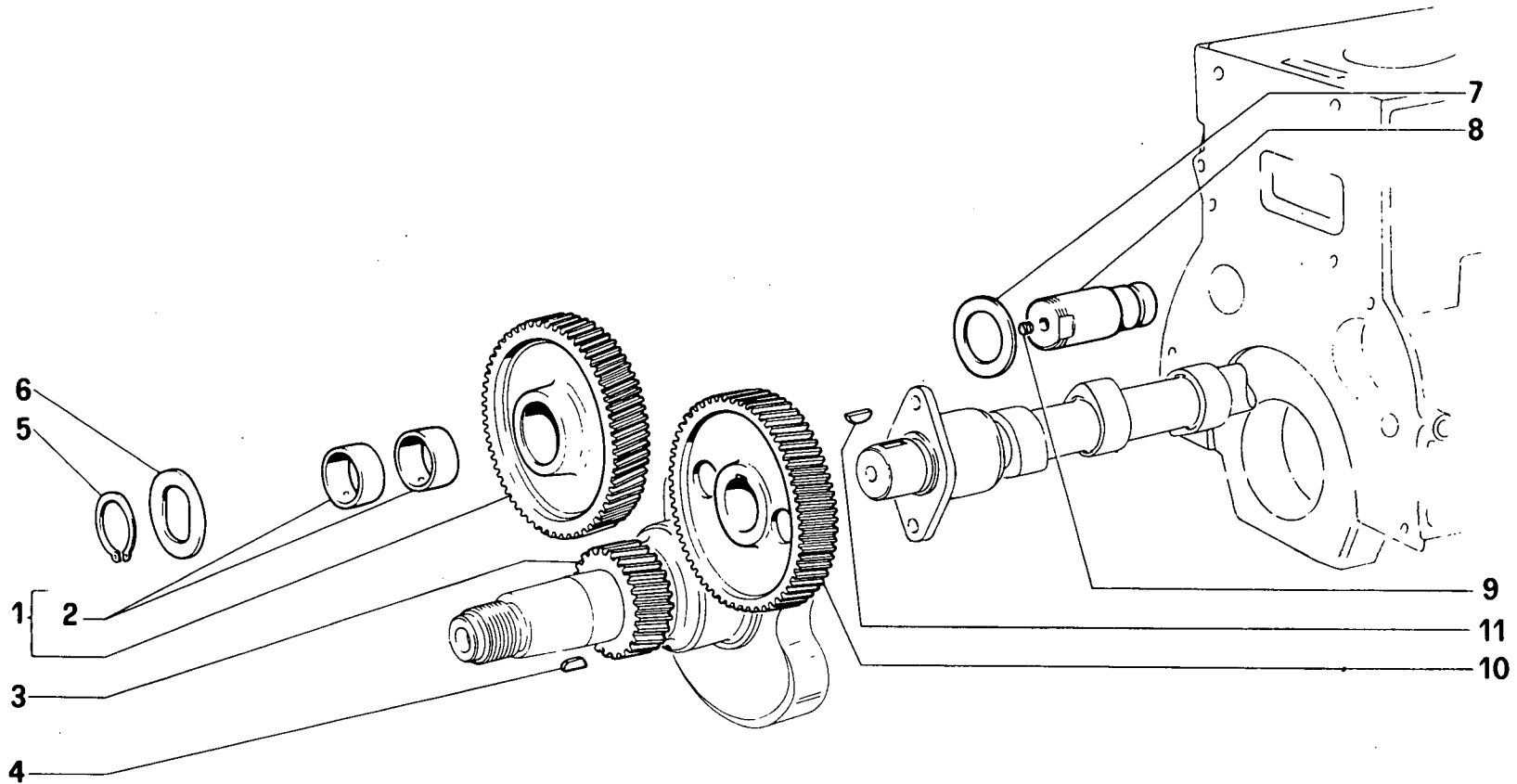

C80/50

COMANDO DISTRIBUZIONE

10.03/01

(09-1981)

FIG	N. ORDINAZIONE	QTA	DENOMINAZIONE	DESIGNATION	BENENNUNG	DESCRIPTION	DENOMINACIONES
1	4607743	1	INGRANAGGIO INTERMEDIO	REDUCTEUR	ZWISCHENGETRIEBE	INTERMEDIATE GEAR	ENGRANAJE INTERMED.
2	4599807	2	BOCCOLA	DOUILLE	BUECHSE	BUSH	CASQUILLO
3	4607764	1	INGRANAGGIO CONDUTTORE	PIGNON CONDUCTEUR	TREIBENDES ZAHNRAD	DRIVING GEAR	PINON CONDUCTOR
4	4606664	1	LINGUETTA	LINGUET	SCHEIBENFEDER	KEY	CHAVETA
5	4600329	1	ANELLO DI SICUREZZA	ARRETOIR	SICHERUNGSRING	LOCKRING	ANILLO DE FRENO
6	4667450	1	RONDELLA DI SPALLAMENTO	RONDELLE	TOPFSCHIEBE	CUP	PLATO DE COPA
7	4667451	1	RONDELLA DI SPALLAMENTO	RONDELLE	TOPFSCHIEBE	CUP	PLATO DE COPA
8	4600328	1	PERNO	AXE	BOLZEN	PIN	EJE
9	14328101	1	TAPPO	BOUCHON	STOPFEN	PLUG	TAPON
10	4607511	1	INGRANAGGIO CONDOTTO	PIGNON CONDUIT	ANGETRIEBENES ZAHNRAD	DRIVEN GEAR	PINON CONDUCTIDO
11	10205910	1	LINGUETTA	LINGUET	SCHEIBENFEDER	KEY	CHAVETA

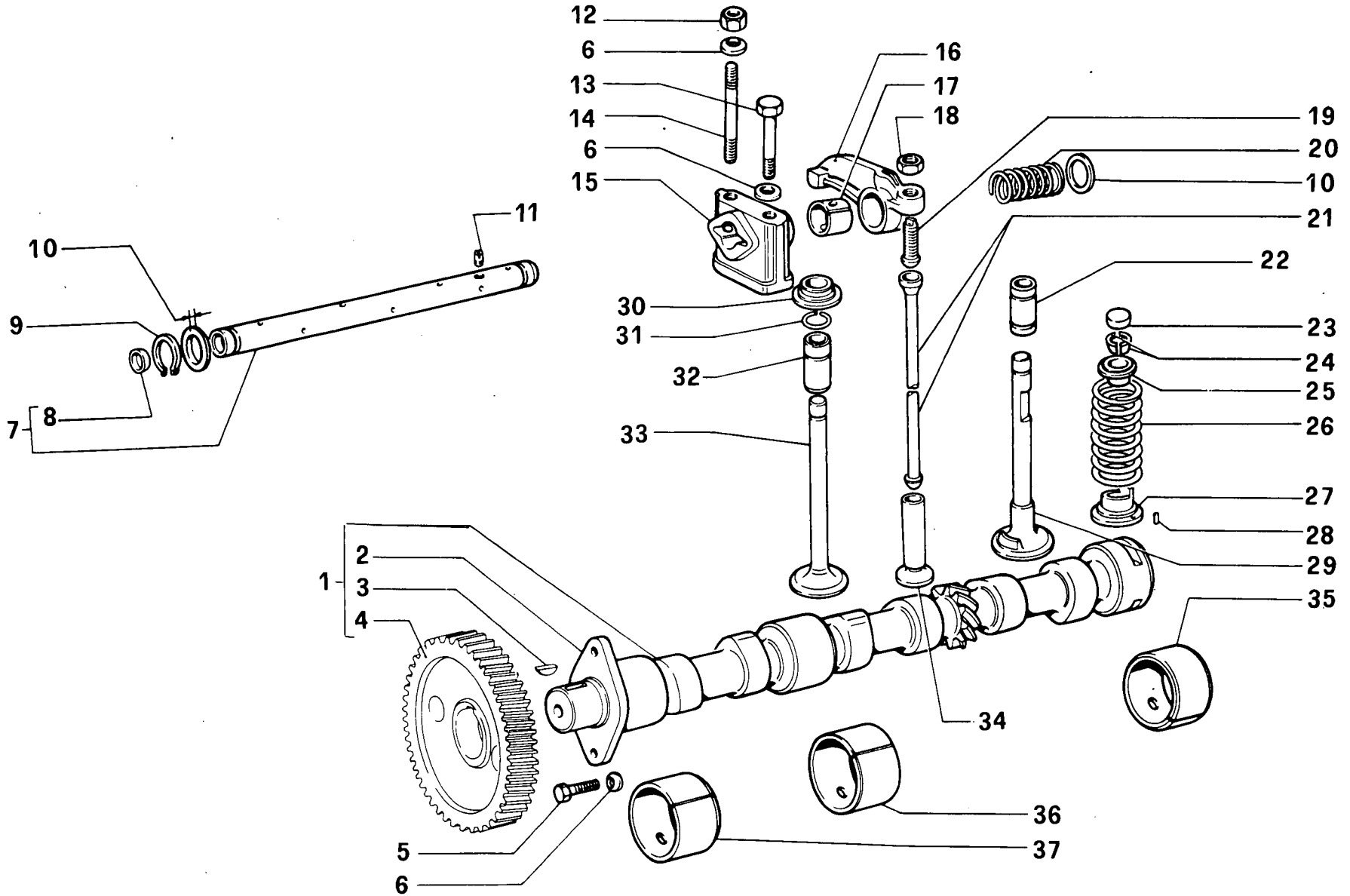

C80/50

DISTRIBUZIONE

10.03/02

(09-1981)

FIG	N. ORDINAZIONE	QTA	DENOMINAZIONE	DESIGNATION	BENENNUNG	DESCRIPTION	DENOMINACIONES
1	4603298	1	ALBERO AD ECCENTRICI	ARBRE A GAMES	EXZENTERWELLE	CAMSHAFT	ARBOL DE LEVAS
2	4599398	1	PIASTRA	PLAQUE	PLATTE	PLATE	PLACA
3	10205910	1	LINGUETTA	LINGUET	SCHEIBENFEDER	KEY	CHAVETA
4	4607511	1	INGRANAGGIO CONDOTTO	PIGNON CONDUIT	ANGETRIEBENES ZAHNRAD	DRIVEN GEAR	PINON CONDUCIDO
5	16043421	2	VITE	VIS	SCHRAUBE	SCREW	TORNILLO
6	11198071	8	ROSETTA DI SICUREZZA	RONDELLE FREIN	SICHERUNGSRING	LOCKWASHER	ARANDELA DE FRENO
7	4671840	1	ALBERO COMPLETO	ARBRE	WELLE	SHAFT	ARBOL
8	14328301	2	TAPPO	BOUCHON	STOPFEN	PLUG	TAPON
9	11066676	2	ANELLO DI SICUREZZA	ARRETOIR	SICHERUNGSRING	LOCKRING	ANILLO DE FRENO
10	4570799	4	ROSETTA PIANA SP 0,5	RONDELLE	SCHEIBE	WASHER	ARANDELA
10	4570798	-	ROSETTA PIANA SP 0,7	RONDELLE	SCHEIBE	WASHER	ARANDELA
10	4639661	-	ROSETTA PIANA SP 1	RONDELLE	SCHEIBE	WASHER	ARANDELA
11	563652	1	VITE	VIS	SCHRAUBE	SCREW	TORNILLO
12	16100811	3	DADO	ECROU	MUTTER	NUT	TUERCA
13	16044521	3	VITE	VIS	SCHRAUBE	SCREW	TORNILLO
14	13516221	4	PRIGIONIERO	GOUJON	STIFTSCHRAUBE	STUD	ESPARRAGO
15	4601295	3	SUPPORTO BILANCIERE	SUPPORT CULBUTEURS	VENTILHEBELBOCK	ROCKER BRACKET	CABALLETE BALANC.
16	4609132	3	BILANCIERE COMPLETO	CULBUTEUR	KIPPEBEL	ROCKER	BALANCIN
17	4577183	6	BOCCOLA	DOUILLE	BUECHSE	BUSH	CASQUILLO
18	4338920	6	DADO	ECROU	MUTTER	NUT	TUERCA
19	4699783	6	VITE DI REGISTRO	VIS DE REGLAGE	EINSTELLSCHRAUBE	ADJUSTING SCREW	TORNILLO GRADUACION
20	4601296	2	MOLLA	RESSORT	FEDER	SPRING	RESORTE
21	4622850	3	ASTA COM. BILANCIERI	TIGE	STANGE	ROD	VARILLA
22	4648421	3	GUIDA VALVOLA ASPIR.	GUIDE SOUPAPE	EINLASSVENTILFUEH- RUNG	INTAKE VALVE GUIDE	GUIA VALVULA DE ADMISSION
22	4648422	-	GUIDA VALVOLA ASP. +0.2	GUIDE SOUPAPE D'ADMISS.	EINLASSVENTILFUEH- RUNG	INTAKE VALVE GUIDE	GUIA VALVULA D'ADMISSION
23	4625173	6	CAPPELOTTO VALVOLE	CHAPEAU	SCHUTZKAPPE	CAP	CAPUCHON
24	14196670	12	SEMICONO PUNTERIE	DEMI-CONE	KEGELSTUECK	LOCK CONE	CHAVETA CONICA
25	4578175	6	SCODELLINO SUP.	CUVETTE	TELLERSCHEIBE	CUP	PLATILLO
26	4689554	6	MOLLA	RESSORT	FEDER	SPRING	RESORTE
27	4601302	3	SCODELLINO INF.	CUVETTE	TELLERSCHEIBE	CUP	PLATILLO
28	10329910	3	SPINA	GOUPILLE	STIFT	PIN	PASADOR
29	4621511	3	VALVOLA DI ASPIRAZIONE	SOUPAPE D'ADMISSION	EINLASSVENTIL	INTAKE VALVE	VALVULA DE ADMISION

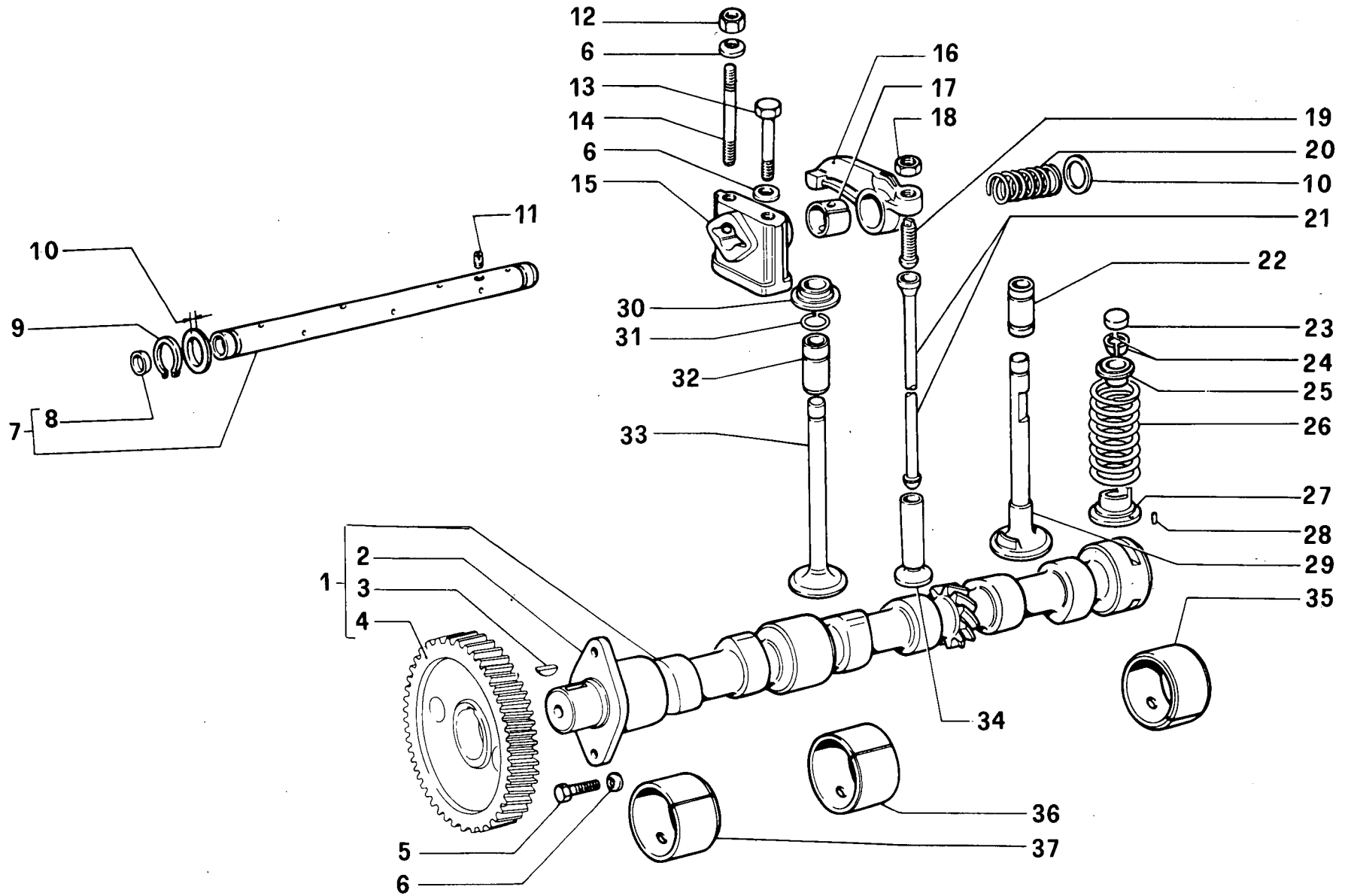

C80/50

DISTRIBUZIONE

10.03/02

(09-1981)

FIG	N. ORDINAZIONE	QTA	DENOMINAZIONE	DESIGNATION	BENENNUNG	DESCRIPTION	DENOMINACIONES
30	4673610	3	SCODELLINO INF.	CUVETTE	TELLERSCHEIBE	CUP	PLATILLO
31	4231247	3	ANELLO DI RITEGNO	ARRETOIR	HALTERING	RETAINER	RETENEDOR
32	4676070	3	GUIDA VALVOLA SCAR.	GUIDE SOUPAPE D'ECHAPP.	AUSLASSVENTILFUEH- RUNG	EXHAUST VALVE GUIDE	GUIA VALVULA DE ESCAPE
32	4676071	-	GUIDA VALVOLA SCAR. +0.2	GUIDE SOUPAPE D'ECHAPP.	AUSLASSVENTILFUEH- RUNG	EXHAST VALVE GUIDE	GUIA VALVULA' DE ESCAPE
33	4673608	3	VALVOLA DI SCARICO	SOUPAPE D'ECHAPPEMENT	AUSLASSVENTIL	EXHAUST VALVE	VALVULA DE ESCAPE
34	4693029	6	PUNTERIA	POUSSOIR	STOESSEL	TAPPET	EMPUJADOR
34	4693030	-	PUNTERIA +0,1	POUSSOIR	STOESSEL	TAPPET	EMPUJADOR
34	4693031	-	PUNTERIA +0.2	POUSSOIR	STOESSEL	TAPPET	EMPUJADOR
34	4693032	-	PUNTERIA +0.3	POUSSOIR	STOESSEL	TAPPET	EMPUJADOR
35	4603451	1	BOCCOLA POSTERIORE	DOUILLE	BUECHSE	BUSH	CASQUILLO
36	4603450	1	BOCCOLA CENTRALE	DOUILLE	BUECHSE	BUSH	CASQUILLO
37	4603449	1	BOCCOLA ANTERIORE	DOUILLE	BUECHSE	BUSH	CASQUILLO

Graissage
Schmierung

Lubrication System
Sistema de engrase

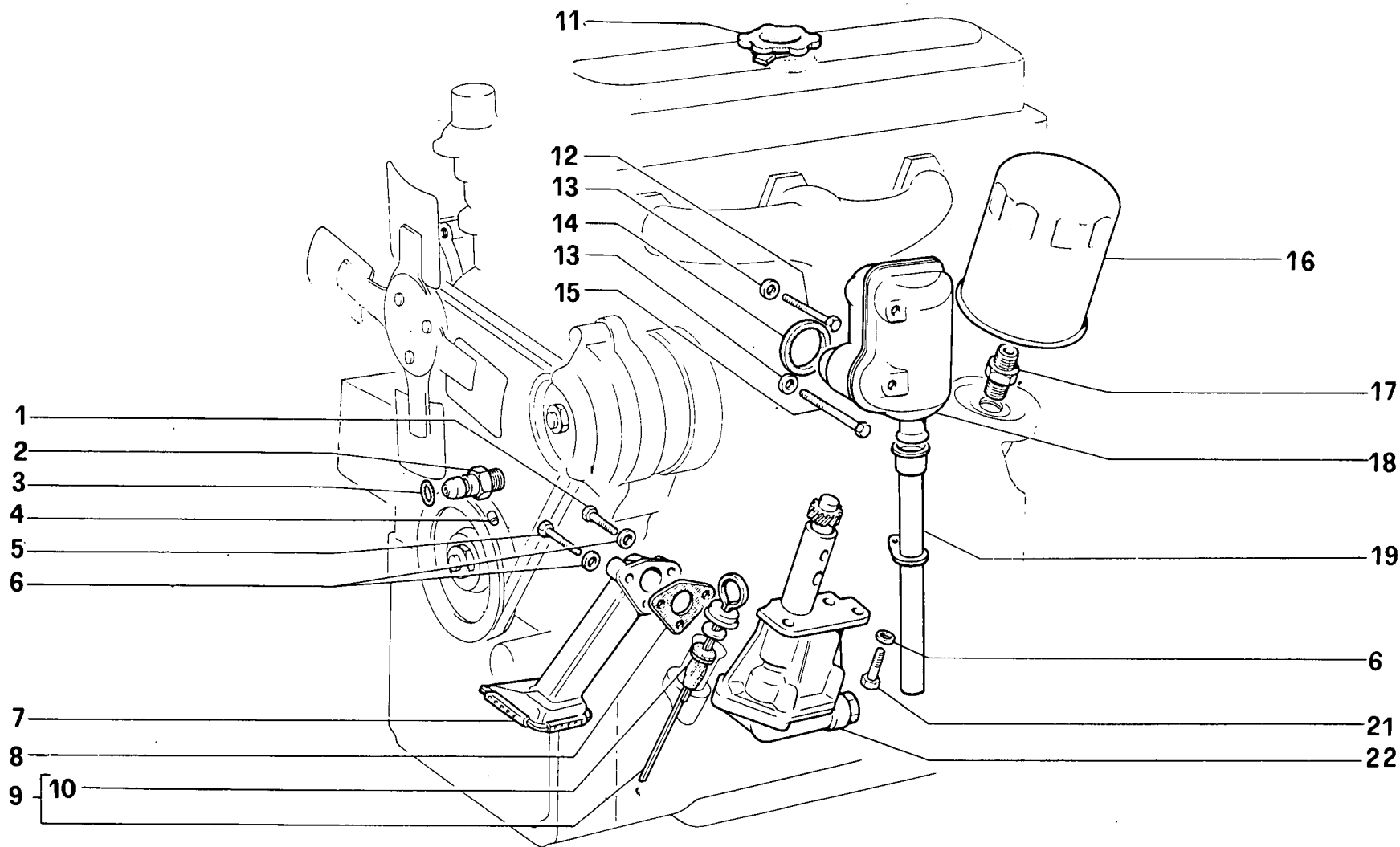

C80/50

LUBRIFICAZIONE

10.05/01

(09-1981)

FIG	N. ORDINAZIONE	QTA	DENOMINAZIONE	DESIGNATION	BENENNUNG	DESCRIPTION	DENOMINACIONES
1	16044021	2	VITE	VIS	SCHRAUBE	SCREW	TORNILLO
2	4607670	1	BOCCHETTONE	VIS-RACCORD	HOLHLSCHRAUBE	UNION	BOQUILLA
3	561293	1	ANELLO DI TENUTA	JOINT D'ETANCHEITE	DICHTRING	SEAL	JUNTA HERMETICA
4	4605220	1	UGELLO	GICLEUR	DUESE	JET	BOQUILLA
5	16044321	1	VITE	VIS	SCHRAUBE	SCREW	TORNILLO
6	11198071	6	ROSETTA DI SICUREZZA	RONDELLE FREIN	SICHERUNGSRING	LOCKWASHER	ARANDELA DE FRENO
7	4705910	1	SUCCHIERUOLA	CREPINE	SAUGKORB	SCOOP	COLADOR
8	4705835	1	GUARNIZIONE	GARNITURE	DICHTUNG	GASKET	JUNTA
9	4608223	1	ASTA LIVELLO OLIO	JAUGE D'HUILE	OELMESSSTAB	OIL DIPSTICK	VARIL. NIVEL ACEITE
10	4624702	1	GUARNIZIONE	GARNITURE	DICHTUNG	GASKET	JUNTA
11	4232606	1	TAPPO	BOUCHON	STOPFEN	PLUG	TAPON
12	16044921	1	VITE	VIS	SCHRAUBE	SCREW	TORNILLO
13	10260060	3	GUARNIZIONE	GARNITURE	DICHTUNG	GASKET	JUNTA
14	4600893	1	GUARNIZIONE	GARNITURE	DICHTUNG	GASKET	JUNTA
15	16045621	1	VITE	VIS	SCHRAUBE	SCREW	TORNILLO
16	4600875	1	CARTUCCIA	CARTOUCHE	PATRONE	CARTRIDGE	CARTUCHO
17	4262887	1	RACCORDO	RACCORD	STUTZEN	CONNECTION	RACOR
18	4624515	1	SFIATATOIO	RENIFLARD	ENTLUEFTER	VENT	RESPIRADERO
19	4614608	1	TUBO	TUBE/TUYAU	ROHR	PIPE/TUBE	TUBO
21	16043621	2	VITE	VIS	SCHRAUBE	SCREW	TORNILLO
22	4705827	1	POMPA OLIO	POMPE A HUILE	OELPUMPE	OIL PUMP	BOMBA DE ACEITE

C80.50

01 02 03

LUBRIFICAZIONE

Graissage
Schmierung

Lubrication System
Sistema de engrase

10.5/2

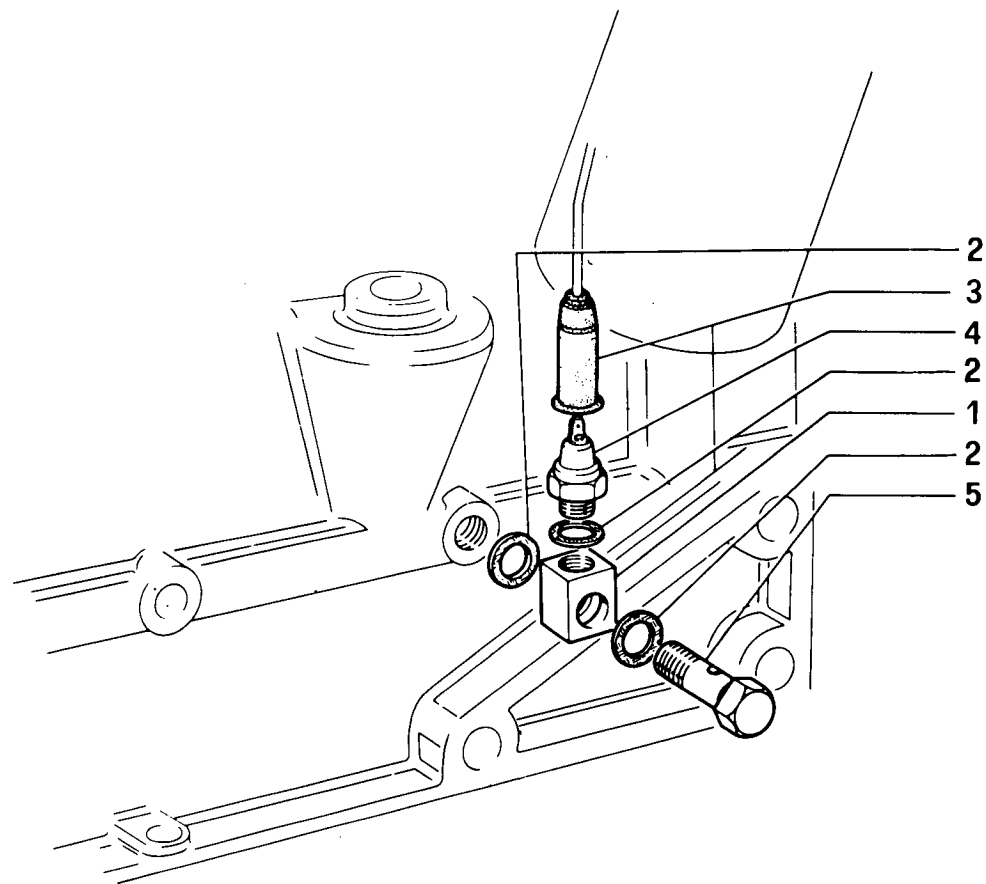

C80/50

LUBRIFICAZIONE

10.05/02

(09-1981)

FIG	N. ORDINAZIONE	QTA	DENOMINAZIONE	DESIGNATION	BENENNUNG	DESCRIPTION	DENOMINACIONES
1	598310	1	RACCORDO	RACCORD	STUTZEN	CONNECTION	RACOR
2	10298460	3	GUARNIZIONE	GARNITURE	DICHTUNG	GASKET	JUNTA
3	5108206	1	CAPPUCCIO	CAPUCHON	STAUBSCHUTZKAPPE	BOOT	CAPUCHON
4	5107603	1	INTERRUTTORE	INTERRUPTEUR	SCHALTER	SWITCH	INTERRUPTOR
5	598311	1	BOCCHETTONE	VIS-RACCORD	HOLHLSCHRAUBE	UNION	BOQUILLA

CEB.50

01 02 03

POMPA OLIO

Pompe à huile
Ölpumpe

Oil pump
Bomba de aceite

10.5/3

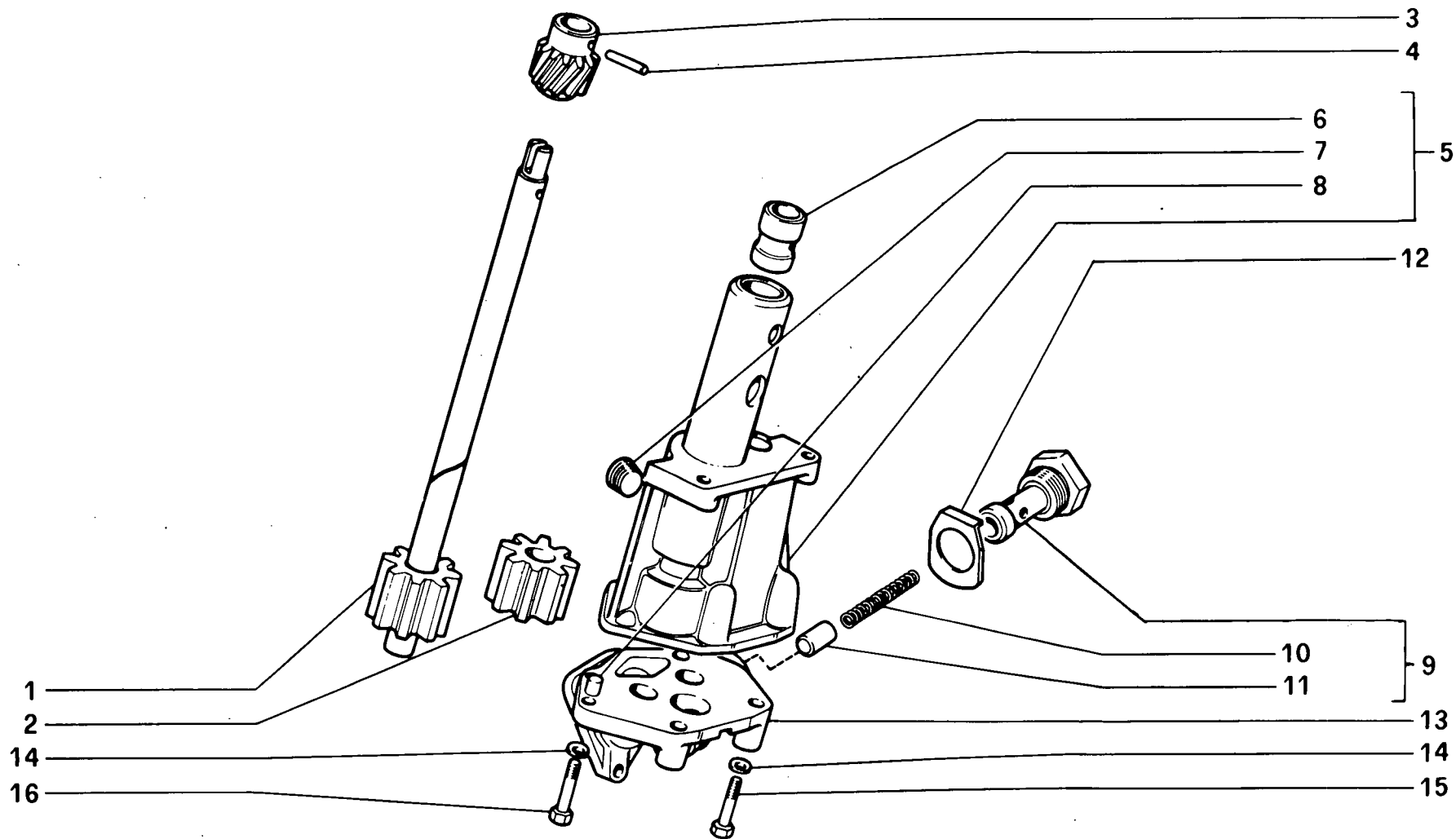

C80/50

POMPA OLIO

10.05/03

(09-1981)

FIG	N. ORDINAZIONE	QTA	DENOMINAZIONE	DESIGNATION	BENENNUNG	DESCRIPTION	DENOMINACIONES
	4705827	1	POMPA OLIO	POMPE A HUILE	OELPUMPE	OIL PUMP	BOMBA DE ACEITE
1	4705834	1	ALBERO	ARBRE	WELLE	SHAFT	ARBOL
2	4705831	1	INGRANAGGIO CONDOTTO	PIGNON CONDUIT	ANGETRIEBENES ZAHNRAD	DRIVEN GEAR	PINON CONDUcido
3	4599726	1	INGRANAGGIO CONDOTTO	PIGNON CONDUIT	ANGETRIEBENES ZAHNRAD	DRIVEN GEAR	PINON CONDUcido
4	4605293	1	SPINA	GOUPILLE	STIFT	PIN	PASADOR
5	4705833	1	CORPO POMPA OLIO	CORPS POMPE HUILE	OELPUMPENGEHAUSE	PUMP HOUSING	CAJA BOMBA ACEITE
6	4673692	1	BOCCOLA	DOUILLE	BUECHSE	BUSH	CASQUILLO
7	14325101	1	TAPPO	BOUCHON	STOPFEN	PLUG	TAPON
8	10839510	1	SPINA	GOUPILLE	STIFT	PIN	PASADOR
9	4707153	1	VALVOLA COMPLETA	SOUPAPE	VENTIL	VALVE	VALVULA
10	4587731	1	MOLLA	RESSORT	FEDER	SPRING	RESORTE
11	4587730	1	VALVOLA	SOUPAPE	VENTIL	VALVE	VALVULA
12	4604941	1	PIASTRINA DI SICUREZZA	PLAQUETTE FREIN	SICHERUNGSBLECH	LOCKPLATE	PLACA DE FRENO
13	4705829	1	COPERCHIO	COUVERCLE	DECKEL	COVER	TAPA
14	11198071	4	ROSETTA DI SICUREZZA	RONDELLE FREIN	SICHERUNGSRING	LOCKWASHER	ARANDELA DE FRENO
15	16044021	2	VITE	VIS	SCHRAUBE	SCREW	TORNILLO
16	16044221	4	VITE	VIS	SCHRAUBE	SCREW	TORNILLO

ALIMENTAZIONE AD INIEZIONE (C.A.V.)

Alimentation par injection
Einspritzausrüstung

Fuel Injection System
Alimentación e inyección

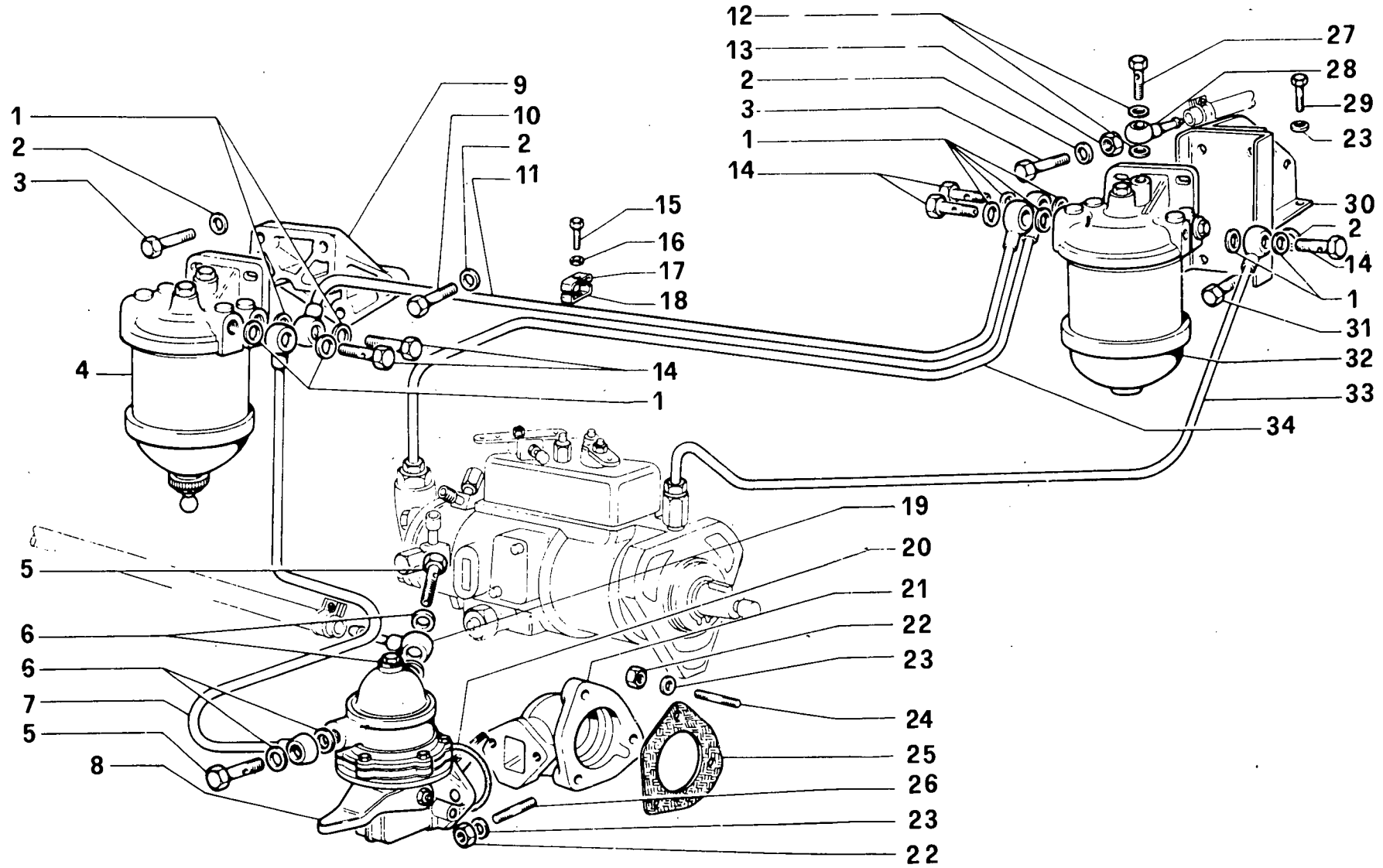

C80/50

ALIMENTAZIONE AD INIEZIONE C.A.V.

10.06/01

(09-1981)

FIG	N. ORDINAZIONE	QTA	DENOMINAZIONE	DESIGNATION	BENENNUNG	DESCRIPTION	DENOMINACIONES
1	10280060	10	GUARNIZIONE DI TENUTA	JOINT	DICHTUNG	GASKET	JUNTA
2	11198371	8	ROSETTA DI SICUREZZA	RONDELLE FREIN	SICHERUNGSRING	LOCKWASHER	ARANDELA DE FRENO
3	11306921	2	VITE	VIS	SCHRAUBE	SCREW	TORNILLO
4	4612229	1	FILTRO COMBUSTIBILE	FILTRE A COMBUSTIBLE	KRAFTSTOFFFILTER	FUEL FILTER	FILTRO DE COMBUSTIBLE
5	10181711	4	BOCCHETTONE	VIS-RACCORD	HOLHLSCHRAUBE	UNION	BOQUILLA
6	10296160	4	GUARNIZIONE DI TENUTA	JOINT	DICHTUNG	GASKET	JUNTA
7	4619233	1	TUBO DA POMPA AC. A FILTRO	TUBE/TUYAU	ROHR	PIPE/TUBE	TUBO
8	4740717	1	POMPA DI ALIMENTAZIONE	POMPE D'ALIMENTAZIONE	KRAFTSTOFFPUMPE	FUEL PUMP	BOMBA DE ALIMENTAZIONE
9	4615697	1	SUPPORTO	SUPPORT	LAGER	SUPPORT	SOPORTE
10	15888821	3	VITE	VIS	SCHRAUBE	SCREW	TORNILLO
11	4621430	1	TUBO DA I A II FILTRO	TUBE/TUYAU	ROHR	PIPE/TUBE	TUBO
12	10260160	2	GUARNIZIONE	GARNITURE	DICHTUNG	GASKET	JUNTA
13	12164711	2	DADO	ECROU	MUTTER	NUT	TUERCA
14	10184311	3	BOCCHETTONE	VIS-RACCORD	HOLHLSCHRAUBE	UNION	BOQUILLA
15	10902421	1	VITE	VIS	SCHRAUBE	SCREW	TORNILLO
16	11197771	1	ROSETTA DI SICUREZZA	RONDELLE FREIN	SICHERUNGSRING	LOCKWASHER	ARANDELA DE FRENO
17	607942	1	MORSETTO SUP.	COLLIER	KLEMME	CLAMP	COLLAR
18	4002890	1	MORSETTO INF.	COLLIER	KLEMME	CLAMP	COLLAR
19	4671700	1	RACCORDO	RACCORD	STUTZEN	CONNECTION	RACOR
20	14458680	1	ANELLO OR	BAGUE TORIQUE	O-RING	O-SEAL	ANILLO O.
21	4607673	1	SUPPORTO	SUPPORT	LAGER	SUPPORT	SOPORTE
22	16100811	5	DADO	ECROU	MUTTER	NUT	TUERCA
23	11198071	5	ROSETTA DI SICUREZZA	RONDELLE FREIN	SICHERUNGSRING	LOCKWASHER	ARANDELA DE FRENO
24	4600631	3	PRIGIONIERO	GOUJON	STIFTSCHRAUBE	STUD	ESPARRAGO
25	4607655	1	GUARNIZIONE	GARNITURE	DICHTUNG	GASKET	JUNTA
26	13516920	2	PRIGIONIERO	GOUJON	STIFTSCHRAUBE	STUD	ESPARRAGO
27	4617972	1	BOCCHETTONE	VIS-RACCORD	HOLHLSCHRAUBE	UNION	BOQUILLA
28	4671701	1	RACCORDO	RACCORD	STUTZEN	CONNECTION	RACOR
29	16043221	2	VITE	VIS	SCHRAUBE	SCREW	TORNILLO
30	4620989	1	SUPPORTO	SUPPORT	LAGER	SUPPORT	SOPORTE
31	15970521	2	VITE	VIS	SCHRAUBE	SCREW	TORNILLO
32	4616707	1	FILTRO COMBUSTIBILE	FILTRE A COMBUSTIBLE	KRAFTSTOFFFILTER	FUEL FILTER	FILTRO DE COMBUSTIBLE

ALIMENTAZIONE AD INIEZIONE (C.A.V.)

Alimentation par injection
Einspritzausrstung

Fuel Injection System
Alimentacin e inyeccin

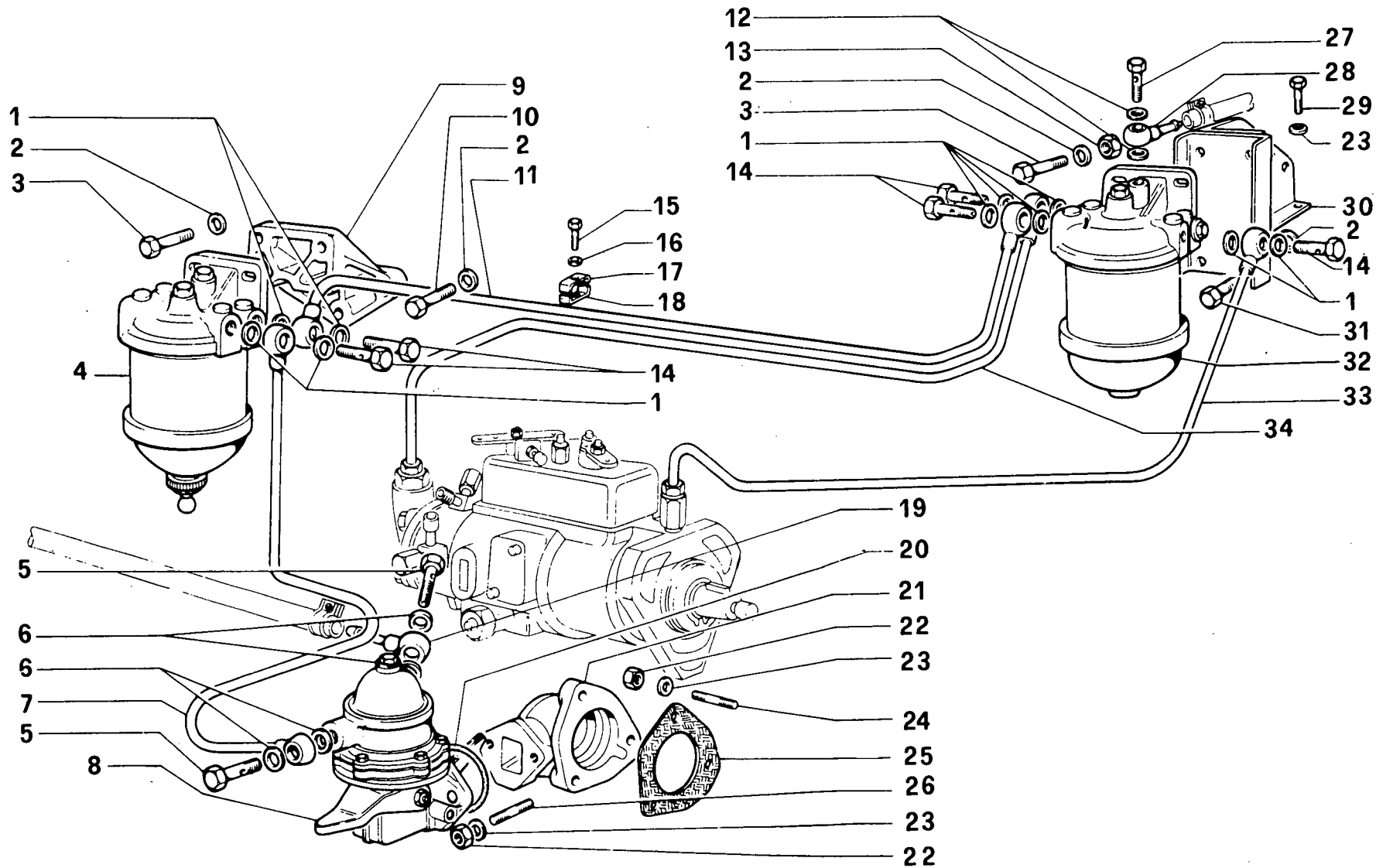

C80/50

ALIMENTAZIONE AD INIEZIONE C.A.V.

10.06/01

(09-1981)

FIG	N. ORDINAZIONE	QTA	DENOMINAZIONE	DESIGNATION	BENENNUNG	DESCRIPTION	DENOMINACIONES
33	4621436	1	TUBO DA FLIT.A POMPA INIE.	TUBE/TUYAU	ROHR	PIPE/TUBE	TUBO
34	4621434	1	TUBO DA POMPA INIEZ.A FIL.	TUBE/TUYAU	ROHR	PIPE/TUBE	TUBO

ALIMENTAZIONE AD INIEZIONE

Alimentation par injection
Einspritzausrüstung

Fuel Injection System
Alimentación e inyección

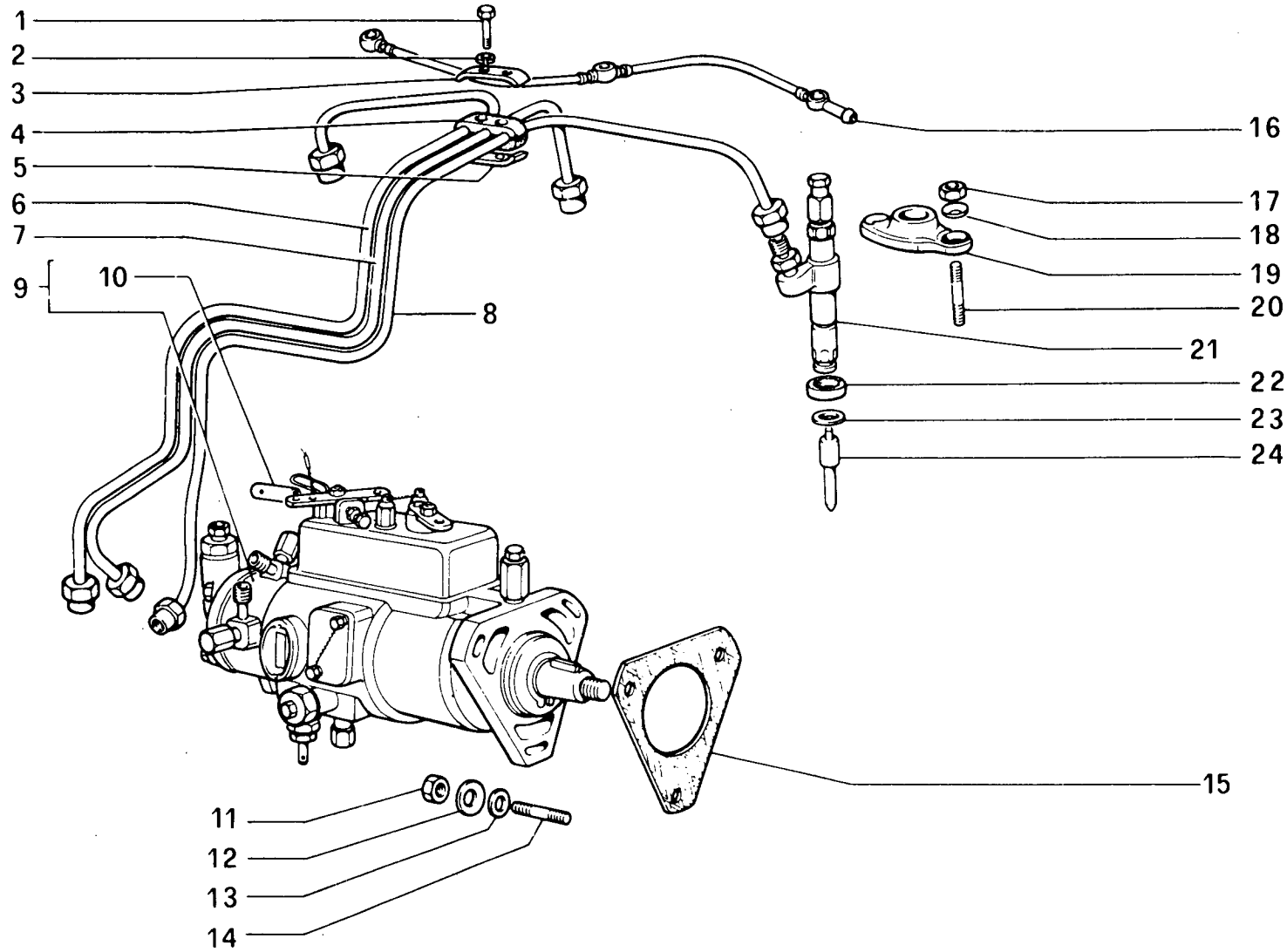

C80/50

ALIMENTAZIONE AD INIEZIONE C.A.V.

10.06/02

(09-1981)

FIG	N. ORDINAZIONE	QTA	DENOMINAZIONE	DESIGNATION	BENENNUNG	DESCRIPTION	DENOMINACIONES
1	10978021	2	VITE	VIS	SCHRAUBE	SCREW	TORNILLO
2	11195471	2	ROSETTA DI SICUREZZA	RONDELLE FREIN	SICHERUNGSRING	LOCKWASHER	ARANDELA DE FRENO
3	4641876	1	MORSETTO SUPERIORE	COLLIER	KLEMME	CLAMP	COLLAR
4	4543282	1	BLOCCHETTO DI FISSAGGIO	TAQUET DI FIXATION	SPANNSTUECK	PAD	MULETILLA DE FIJACION
5	4641875	1	MORSETTO INFERIORE	COLLIER	KLEMME	CLAMP	COLLAR
6	4644325	1	TUBO DA POMPA A 1 CILINDRO	TUBE/TUYAU	ROHR	PIPE/TUBE	TUBO
7	4644326	1	TUBO DA POMPA A 2 CILINDRO	TUBE/TUYAU	ROHR	PIPE/TUBE	TUBO
8	4644327	1	TUBO DA POMPA A 3 CILINDRO	TUBE/TUYAU	ROHR	PIPE/TUBE	TUBO
9	770535	1	POMPA INIEZIONE	POMPE D'INJECTION	EINSPRITZPUMPE	INJECTION PUMP	BOMBA DE INYECCION
10	4617425	1	ASTUCCIO	ETUI	HUELSE	CASE	ESTUCHE
11	16100811	3	DADO	ECROU	MUTTER	NUT	TUERCA
12	11198071	3	ROSETTA DI SICUREZZA	RONDELLE FREIN	SICHERUNGSRING	LOCKWASHER	ARANDELA DE FRENO
13	4564844	3	ROSETTA PIANA	RONDELLE	SCHEIBE	WASHER	ARANDELA
14	4600631	3	PRIGIONIERO	GOUJON	STIFTSCHRAUBE	STUD	ESPARRAGO
15	4607627	1	GUARNIZIONE	GARNITURE	DICHTUNG	GASKET	JUNTA
16	4647814	1	TUBO RECUPERO INIETTORI	TUBE/TUYAU	ROHR	PIPE/TUBE	TUBO
17	16100821	6	DADO	ECROU	MUTTER	NUT	TUERCA
18	771326	6	RONDELLA	RONDELLE	TOPFSCHIEBE	CUP	PLATO DE COPA
18	11198071	6	ROSETTA DI SICUREZZA INIETTORE C.A.V.	RONDELLE FREIN	SICHERUNGSRING	LOCKWASHER	ARANDELA DE FRENO
19	765640	3	STAFFETTA FISSAGGIO	COLLIER	HALTER	RETAINER	ABRAZADERA
20	13517630	6	PRIGIONIERO	GOUJON	STIFTSCHRAUBE	STUD	ESPARRAGO
21	767107	3	PORTAPOLVERIZZATORE	PORTE-INJECTEUR	DUESENHALTER	NOZZLE HOLDER	PORTAINYECTOR
21	770899	-	PORTAPOLVERIZZATORE C.A.V.	PORTE-INJECTEUR	DUESENHALTER	NOZZLE HOLDER	PORTAINYECTOR
21	770958	-	PORTAPOLVERIZZATORE OMAP	PORTE-INJECTEUR	DUESENHALTER	NOZZLE HOLDER	PORTAINYECTOR
21	771065	-	PORTAPOLVERIZZATORE BOSCH	PORTE-INJECTEUR	DUESENHALTER	NOZZLE HOLDER	PORTAINYECTOR
22	767111	3	GUARNIZIONE EST.	GARNITURE	DICHTUNG	GASKET	JUNTA

ALIMENTAZIONE AD INIEZIONE

Alimentation par injection
Einspritzausrüstung

Fuel Injection System
Alimentación e inyección

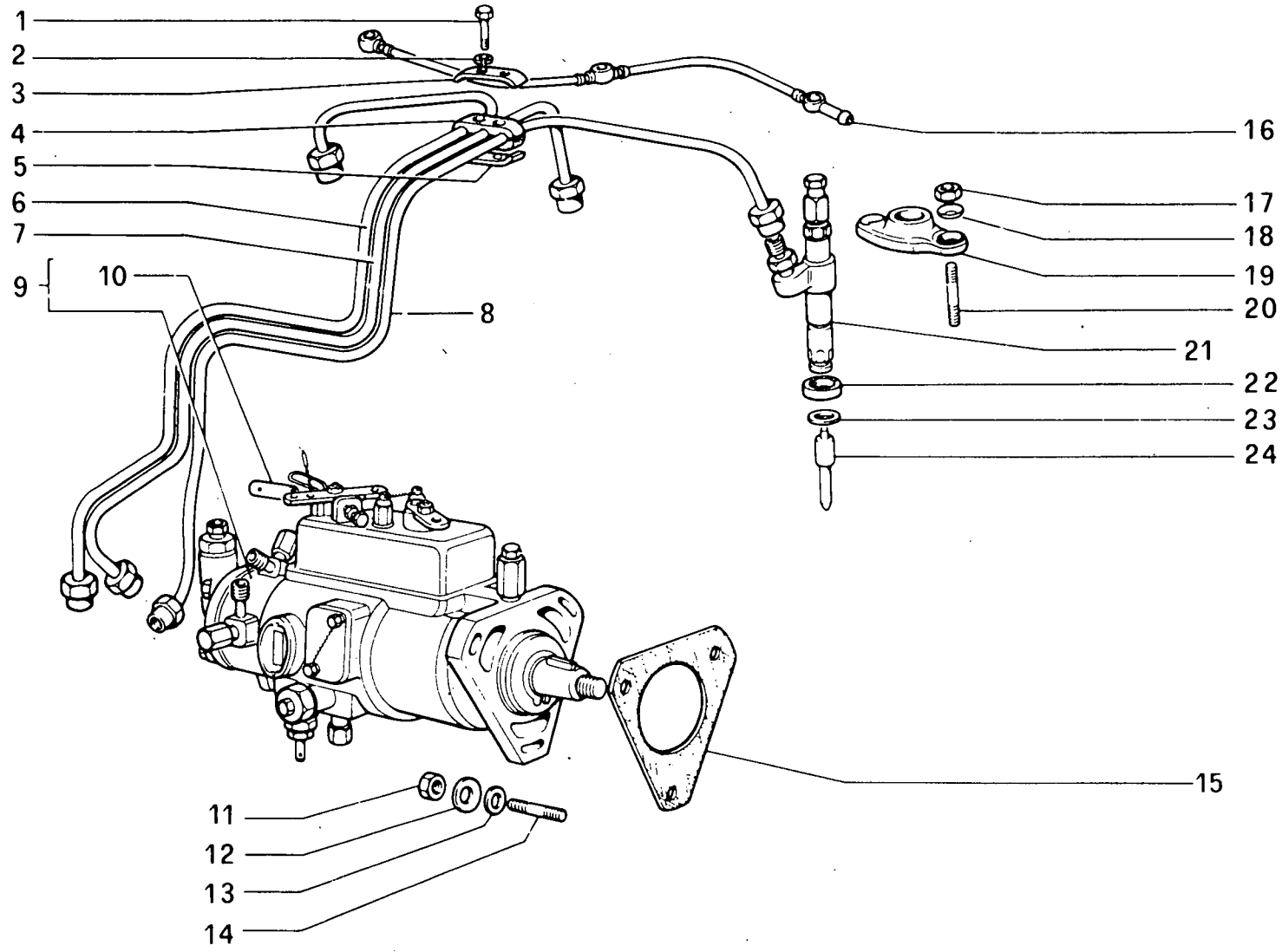

C80/50

ALIMENTAZIONE AD INIEZIONE C.A.V.

10.06/02

(09-1981)

FIG	N. ORDINAZIONE	QTA	DENOMINAZIONE	DESIGNATION	BENENNUNG	DESCRIPTION	DENOMINACIONES
23	767113	3	ANELLO DI TENUTA	JOINT D'ETANCHEITE	DICHTRING	SEAL	JUNTA HERMETICA
24	770578	3	POLVERIZZATORE	INJECTEUR	DUESE	NOZZLE	PULVERIZADOR

CB0.50

01 02 03

COMANDO POMPA INIEZIONE C.A.V.

Commande de pompe d'injection
Einspritzpumpenantrieb

Injection Pump Drive
Arrastre de la bomba de inyección

10.6/3

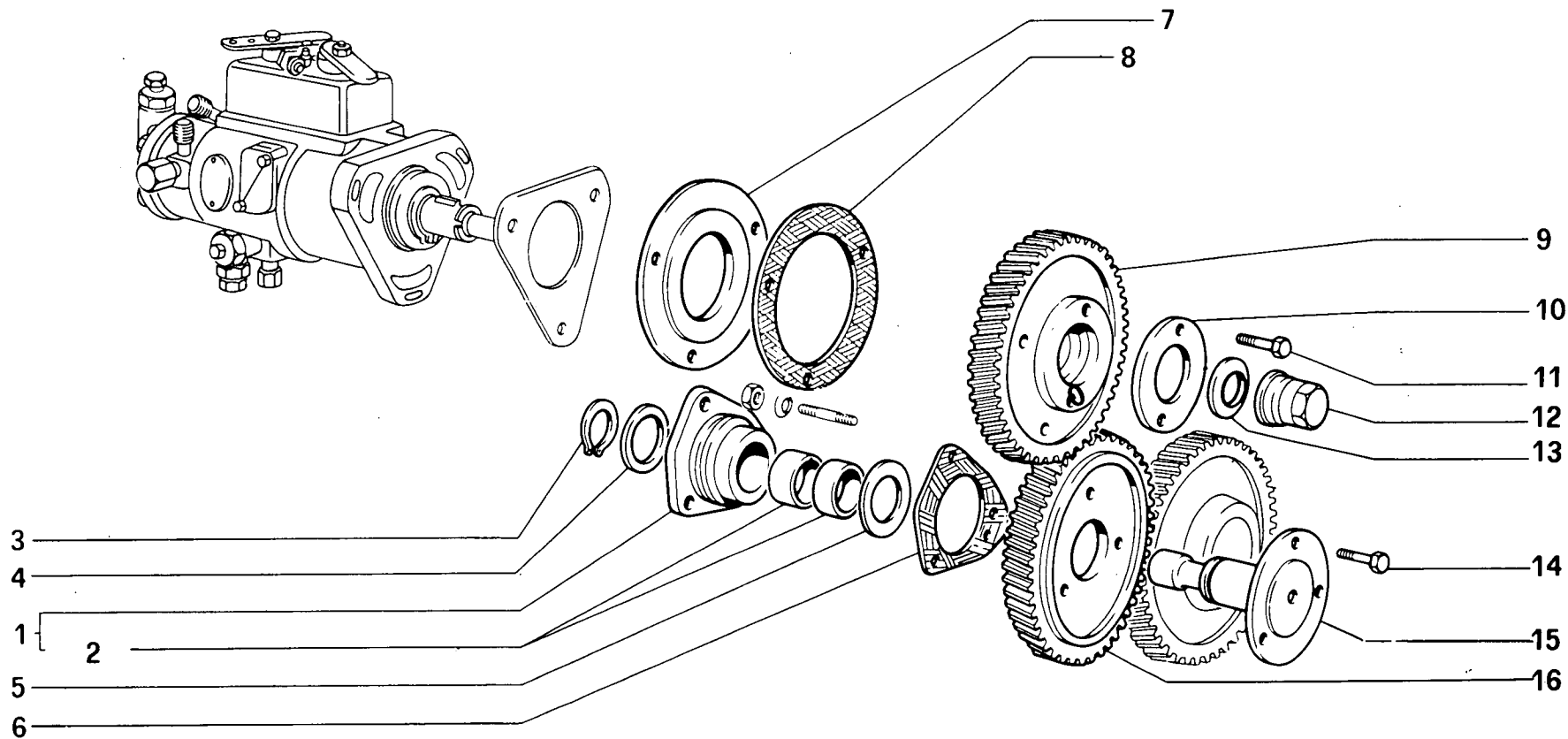

C80/50

COMANDO POMPA INIEZIONE C.A.V.

10.06/03

(09-1981)

FIG	N. ORDINAZIONE	QTA	DENOMINAZIONE	DESIGNATION	BENENNUNG	DESCRIPTION	DENOMINACIONES
1	4607654	1	SUPPORTO	SUPPORT	LAGER	SUPPORT	SOPORTE
2	4599807	2	BOCCOLA	DOUILLE	BUECHSE	BUSH	CASQUILLO
3	4600329	1	ANELLO DI SICUREZZA	ARRETOIR	SICHERUNGSRING	LOCKRING	ANILLO DE FRENO
4	4667450	1	RONDELLA	RONDELLE	TOPFSCHIEBE	CUP	PLATO DE COPA
5	4667451	1	RONDELLA	RONDELLE	TOPFSCHIEBE	CUP	PLATO DE COPA
6	4607655	1	GUARNIZIONE	GARNITURE	DICHTUNG	GASKET	JUNTA
7	4607646	1	DISTANZIALE	ENTRETOISE	ABSTANDSTUECK	SPACER	SEPARADOR
8	4607647	1	GUARNIZIONE	GARNITURE	DICHTUNG	GASKET	JUNTA
9	4662614	1	INGRANAGGIO	PIGNON	ZAHNRAD	GEAR	PINON
10	4607722	1	FLANGIA	BRIDE	FLANSCH	FLANGE	BRIDA
11	14233221	2	VITE	VIS	SCHRAUBE	SCREW	TORNILLO
12	4607721	1	DADO	ECROU	MUTTER	NUT	TUERCA
13	11200171	1	ROSETTA DI SICUREZZA	RONDELLE FREIN	SICHERUNGSRING	LOCKWASHER	ARANDELA DE FRENO
14	14238021	3	VITE	VIS	SCHRAUBE	SCREW	TORNILLO
15	4607652	1	ALBERO	ARBRE	WELLE	SHAFT	ARBOL
16	4607651	1	INGRANAGGIO DI RINVIO	PIGNON DE RENVOI	ZWISCHENZAHNRAD	IDLE GEAR	PINON DE REENVIO

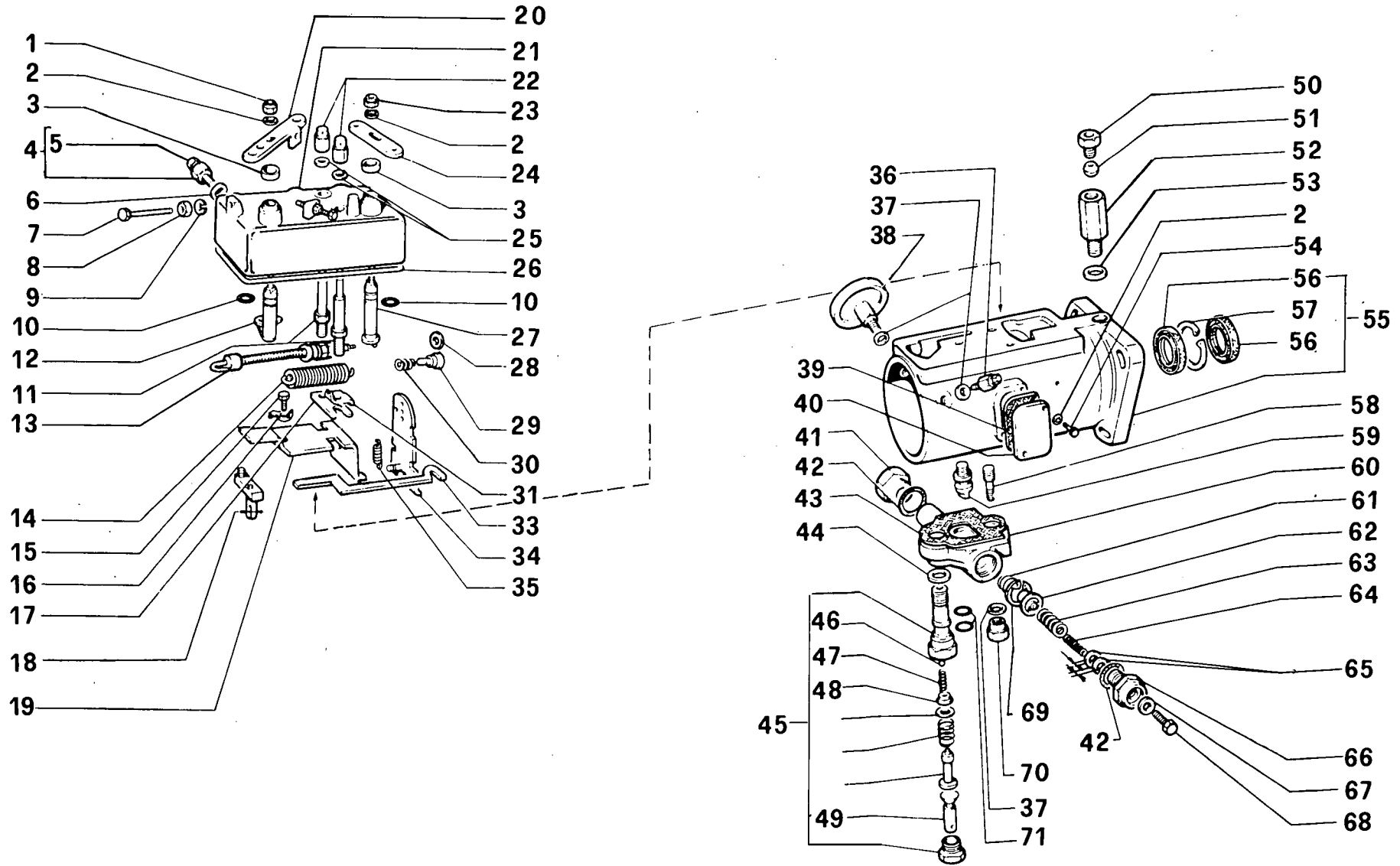

C80/50

POMPA INIEZIONE C.A.V.

10.06/04

(09-1981)

FIG	N. ORDINAZIONE	QTA	DENOMINAZIONE	DESIGNATION	BENENNUNG	DESCRIPTION	DENOMINACIONES
1	9917953	2	DADO	ECROU	MUTTER	NUT	TUERCA
2	9917927	4	ROSETTA DI SICUREZZA	RONDELLE FREIN	SICHERUNGSRING	LOCKWASHER	ARANDELA DE FRENO
3	9917952	2	CAPPUCCIO	CAPUCHON	STAUBSCHUTZKAPPE	BOOT	CAPUCHON
4	9917964	1	VITE DI SFIATO	VIS D'EVENT	ENTLUEFTUNGSSCHRAU- BE	VENT SCREW	TORNILLO DE RESPIRACION
5	9927697	1	VITE	VIS	SCHRAUBE	SCREW	TORNILLO
6	9917965	1	ROSETTA PIANA	RONDELLE	SCHEIBE	WASHER	ARANDELA
7	9917960	2	VITE	VIS	SCHRAUBE	SCREW	TORNILLO
8	9917961	2	DADO	ECROU	MUTTER	NUT	TUERCA
9	9917962	2	ROSETTA DI SICUREZZA	RONDELLE FREIN	SICHERUNGSRING	LOCKWASHER	ARANDELA DE FRENO
10	9917950	4	ANELLO DI TENUTA	JOINT D'ETANCHEITE	DICHTRING	SEAL	JUNTA HERMETICA
11	9917936	2	PRIGIONIERO	GOUJON	STIFTSCHRAUBE	STUD	ESPARRAGO
12	9917954	1	ALBERINO	AXE	WELLE	SHAFT	ARBOL
13	9956304	1	TIRANTE	TIRANT	STANGE	ROD	VARILLA
14	9917956	1	MOLLA	RESSORT	FEDER	SPRING	RESORTE
15	9917934	1	VITE	VIS	SCHRAUBE	SCREW	TORNILLO
16	9929585	1	ROSETTA DI SICUREZZA	RONDELLE FREIN	SICHERUNGSRING	LOCKWASHER	ARANDELA DE FRENO
17	9917931	1	PIASTRA	PLAQUE	PLATTE	PLATE	PLACA
18	9917946	1	VALVOLA	SOUPAPE	VENTIL	VALVE	VALVULA
18	9917947	-	VALVOLA +0.001	SOUPAPE	VENTIL	VALVE	VALVULA
19	9957295	1	STAFFA	ETRIER	HALTER	BRACKET	SOPORTE
20	9917955	1	LEVA	LEVIER	HEBEL	LEVER	PALANCA
21	9917959	1	COPERCHIO	COUVERCLE	DECKEL	COVER	TAPA
22	9917937	2	DADO	ECROU	MUTTER	NUT	TUERCA
23	9917953	2	DADO	ECROU	MUTTER	NUT	TUERCA
24	9917951	1	LEVA	LEVIER	HEBEL	LEVER	PALANCA
25	9917938	2	ROSETTA PIANA	RONDELLE	SCHEIBE	WASHER	ARANDELA
26	9917923	1	GUARNIZIONE	GARNITURE	DICHTUNG	GASKET	JUNTA
27	9917949	1	ALBERINO	AXE	WELLE	SHAFT	ARBOL
28	9918000	1	ROSETTA PIANA	RONDELLE	SCHEIBE	WASHER	ARANDELA
29	9917958	1	GUIDA DELLA MOLLA	GUIDE-RESSORT	FEDERFUEHRUNG	SPRING GUIDE	GUIA DE RESORTE
30	9917957	1	MOLLA	RESSORT	FEDER	SPRING	RESORTE
31	9917932	2	PIASTRINA DI SICUREZZA	PLAQUETTE FREIN	SICHERUNGSBLECH	LOCKPLATE	PLACA DE FRENO
33	9917948	1	TIRANTE	TIRANT	STANGE	ROD	VARILLA
34	9956295	1	PIASTRA	PLAQUE	PLATTE	PLATE	PLACA

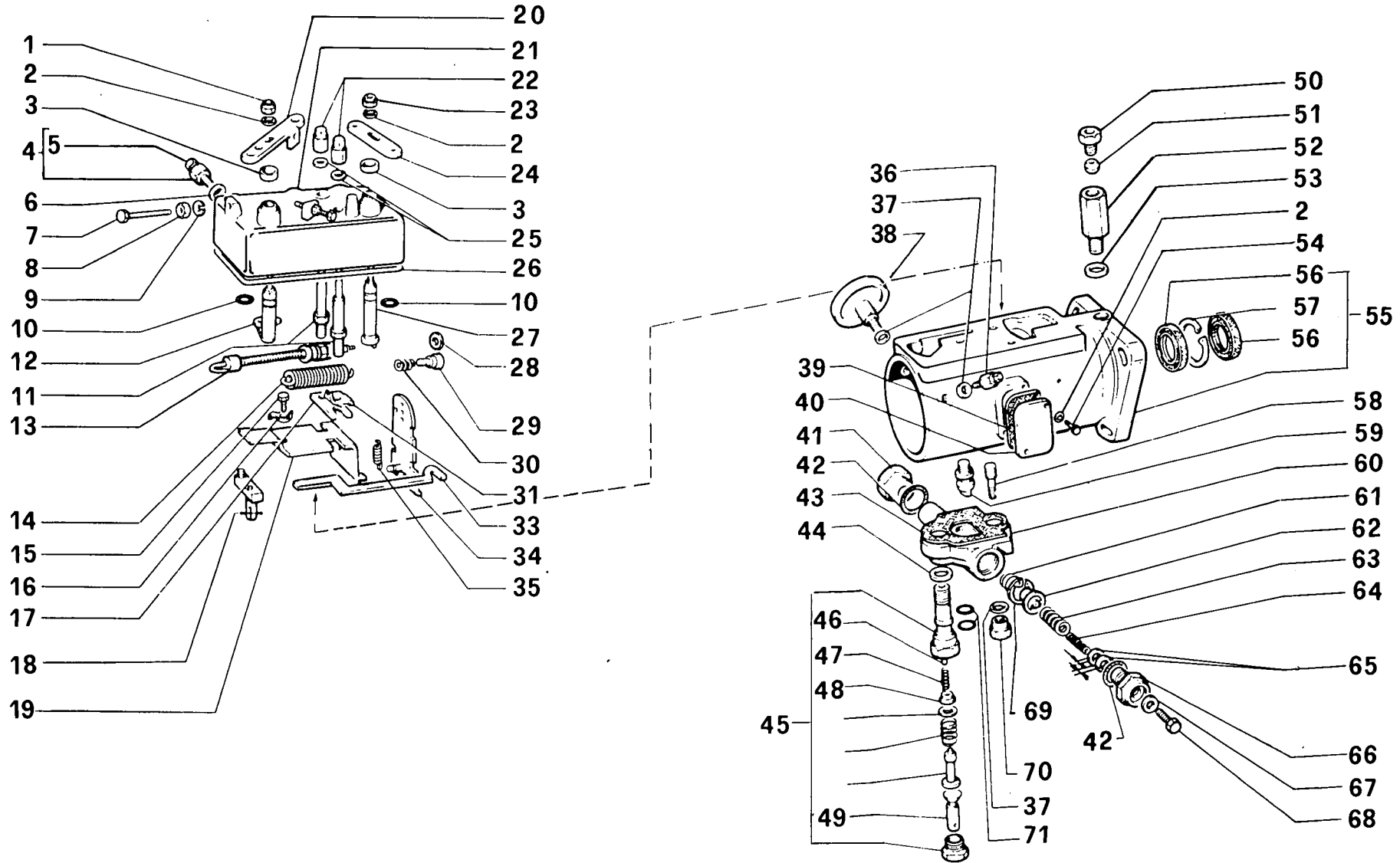
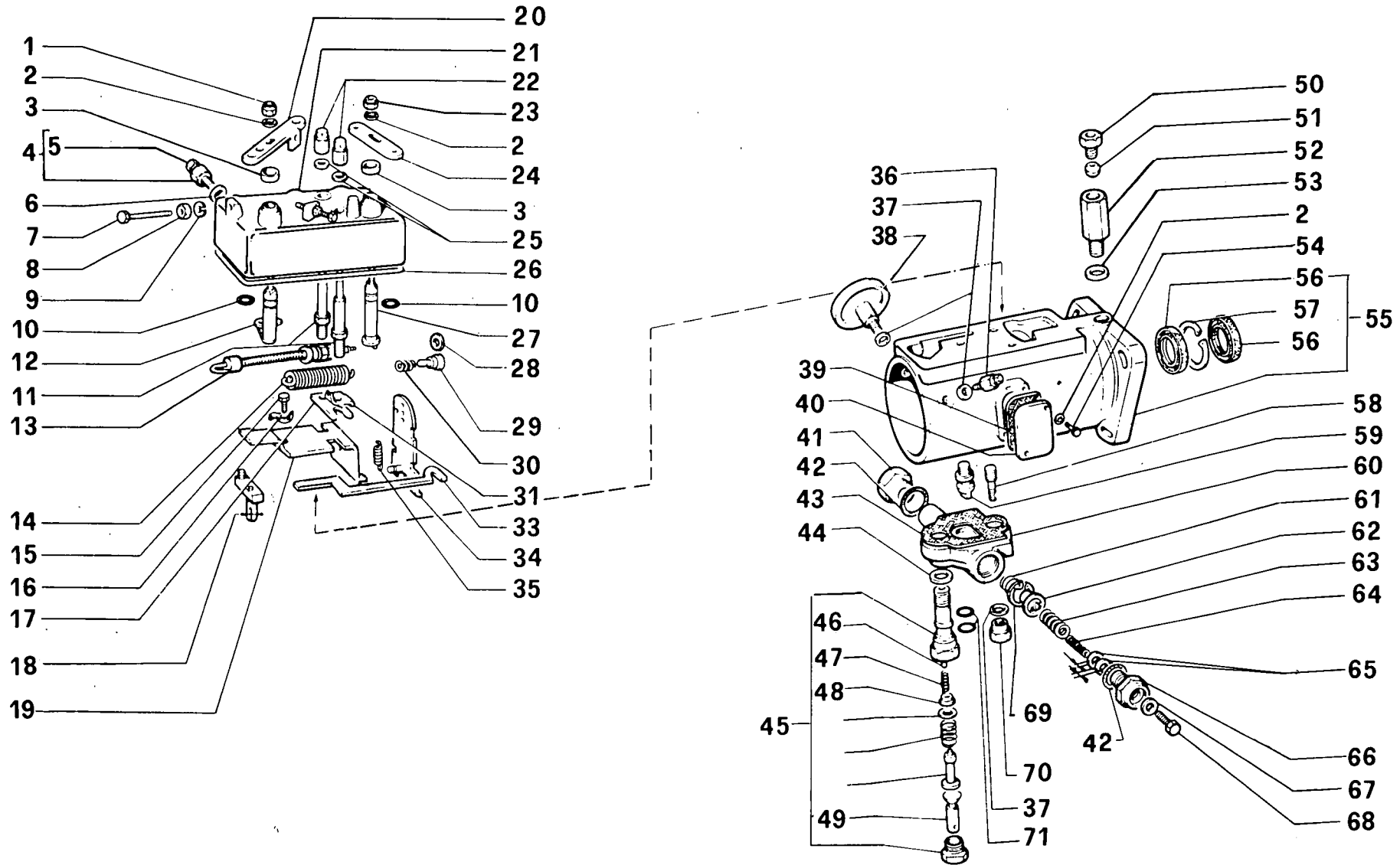

FIG	N. ORDINAZIONE	QTA	DENOMINAZIONE	DESIGNATION	BENENNUNG	DESCRIPTION	DENOMINACIONES
35	9917930	1	MOLLA	RESSORT	FEDER	SPRING	RESORTE
36	9917908	1	VITE DI SFIATO	VIS D'EVENT	ENTLUEFTUNGSSCHRAUBE	VENT SCREW	TORNILLO DE RESPIRACION
37	9922900	3	ROSETTA DI TENUTA	JOINT D'ETANCHEITE	DICHTRING	GASKET	JUNTA HERMETICA
38	9917985	1	STABILIZZATORE	STABILISATEUR	STABILISATOR	STABILIZER	ESTABILIZADOR
39	9917925	1	GUARNIZIONE	GARNITURE	DICHTUNG	GASKET	JUNTA
40	9917924	1	COPERCHIO	COUVERCLE	DECKEL	COVER	TAPA
41	9922909	1	TAPPO	BOUCHON	STOPFEN	PLUG	TAPON
42	9917975	2	ANELLO DI TENUTA	JOINT D'ETANCHEITE	DICHTRING	SEAL	JUNTA HERMETICA
43	9917967	1	GUARNIZIONE	GARNITURE	DICHTUNG	GASKET	JUNTA
44	9917981	1	ROSETTA PIANA	RONDELLE	SCHEIBE	WASHER	ARANDELA
45	9919569	1	COMANDO COMPLETO	COMMANDE	BETAETIGUNGSVOR-	CONTROL	MANDO
46	9919575	1	SFERA	BILLE	KUGEL	BALL	BOLA
47	9929579	1	MOLLA	RESSORT	FEDER	SPRING	RESORTE
48	9919576	1	SCODELLINO	CUVETTE	TELLERSCHEIBE	CUP	PLATILLO
49	9929597	1	LEVA	LEVIER	HEBEL	LEVER	PALANCA
50	9918096	1	RACCORDO	RACCORD	STUTZEN	CONNECTION	RACOR
51	9918095	1	OGIVA DI TENUTA	CONE D'ETANCHEITE	DICHTUNG	SLEEVE	EMPALME CONICO
52	9918988	1	VALVOLA	SOUPAPE	VENTIL	VALVE	VALVULA
53	9920107	1	ROSETTA DI TENUTA	JOINT D'ETANCHEITE	DICHTRING	GASKET	JUNTA HERMETICA
54	9917926	2	VITE	VIS	SCHRAUBE	SCREW	TORNILLO
55	9918001	1	CORPO POMPA	CORPS DE POMPE	PUMPENGEHAUSE	PUMP HOUSING	CAJA BOMBA
56	9917920	1	ANELLO DI TENUTA	JOINT D'ETANCHEITE	DICHTRING	SEAL	JUNTA HERMETICA
57	9917922	1	ANELLO DI SICUREZZA	ARRETOIR	SICHERUNGSRING	LOCKRING	ANILLO DE FRENO
58	9923014	1	PRIGIONIERO	GOUJON	STIFTSCHRAUBE	STUD	ESPARRAGO
59	9917971	1	PERNO SNODO	AXE	BOLZEN	PIN	EJE
60	9922907	1	COPERCHIO	COUVERCLE	DECKEL	COVER	TAPA
61	9922916	1	MOLLA	RESSORT	FEDER	SPRING	RESORTE
62	9917997	1	SCODELLINO	CUVETTE	TELLERSCHEIBE	CUP	PLATILLO
63	9917993	1	MOLLA	RESSORT	FEDER	SPRING	RESORTE
64	9922908	1	MOLLA	RESSORT	FEDER	SPRING	RESORTE
65	9917979	-	ROSETTA PIANA SP 0,2	RONDELLE	SCHEIBE	WASHER	ARANDELA
65	9918092	-	ROSETTA PIANA SP 0,5	RONDELLE	SCHEIBE	WASHER	ARANDELA
65	9922913	-	ROSETTA PIANA SP 1,00	RONDELLE	SCHEIBE	WASHER	ARANDELA
65	9922914	-	ROSETTA PIANA SP 2,00	RONDELLE	SCHEIBE	WASHER	ARANDELA
66	9917976	1	RITEGNO DELLA MOLLA	ARRETOIR DE RESSORT	FEDERHALTER	RETAINER	RETENEDOR DE MUELLE



C80/50

POMPA INIEZIONE C.A.V.

10.06/04

(09-1981)

FIG	N. ORDINAZIONE	QTA	DENOMINAZIONE	DESIGNATION	BENENNUNG	DESCRIPTION	DENOMINACIONES
67	9917978	1	ROSETTA DI TENUTA	JOINT D'ETANCHEITE	DICHTRING	GASKET	JUNTA HERMETICA
68	9922910	1	VITE	VIS	SCHRAUBE	SCREW	TORNILLO
69	9922917	1	ANELLO DI SICUREZZA	ARRETOIR	SICHERUNGSRING	LOCKRING	ANILLO DE FRENO
70	9917969	1	DADO	ECROU	MUTTER	NUT	TUERCA
71	9922915	2	ANELLO DI TENUTA	JOINT D'ETANCHEITE	DICHTRING	SEAL	JUNTA HERMETICA

Pompe d'injection
Einspritzpumpe

Injection Pump
Bomba de inyección

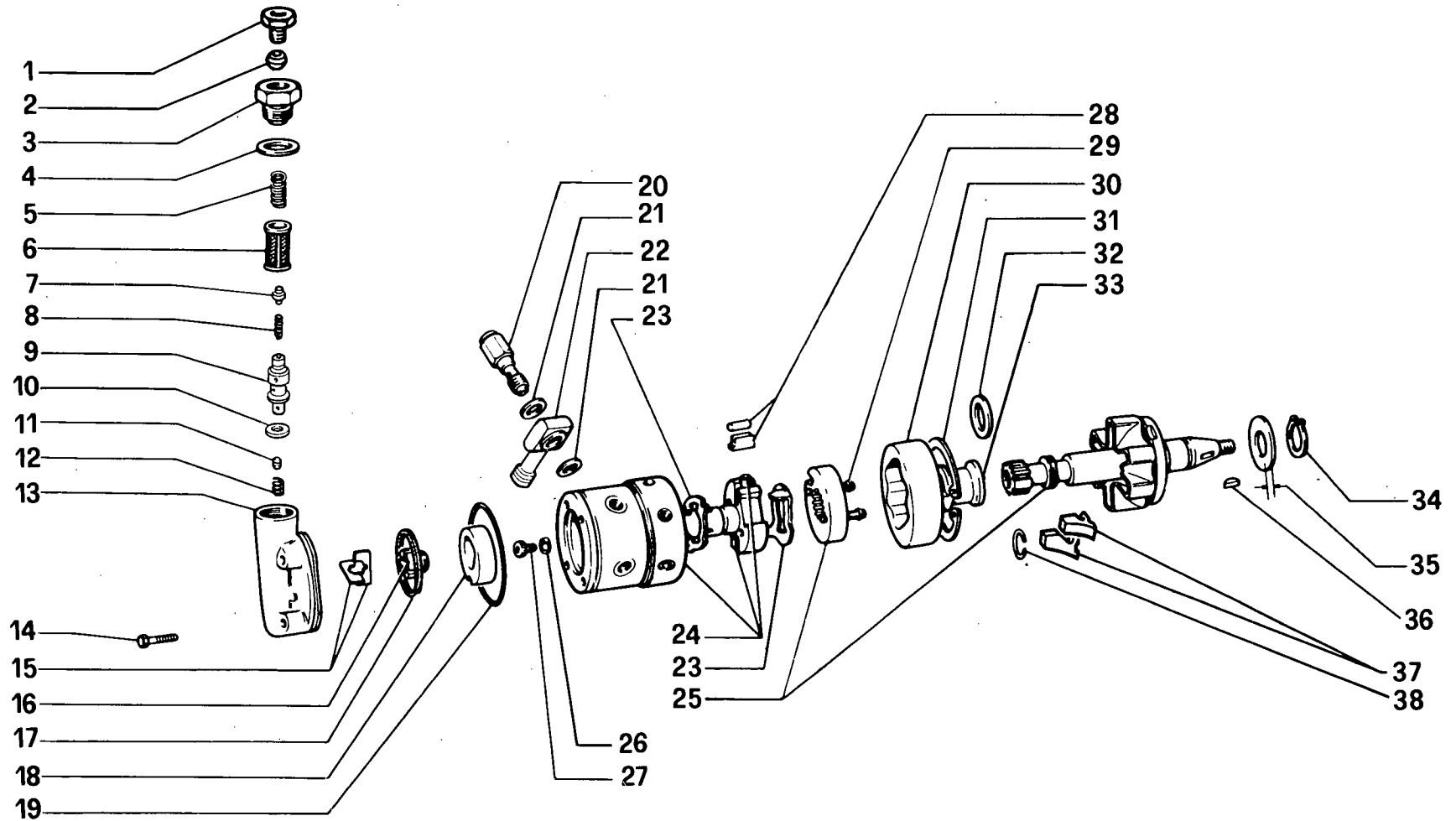

FIG	N. ORDINAZIONE	QTA	DENOMINAZIONE	DESIGNATION	BENENNUNG	DESCRIPTION	DENOMINACIONES
1	9918096	1	RACCORDO	RACCORD	STUTZEN	CONNECTION	RACOR
2	9918095	1	OGIVA DI TENUTA	CONE D'ETANCHEITE	DICHTUNG	SLEEVE	EMPALME CONICO
3	9917894	1	RACCORDO	RACCORD	STUTZEN	CONNECTION	RACOR
4	9917895	1	GUARNIZIONE	GARNITURE	DICHTUNG	GASKET	JUNTA
5	9917893	1	MOLLA	RESSORT	FEDER	SPRING	RESORTE
6	9917890	1	FILTRO	FILTRE	FILTER	FILTER	FILTRO
7	9918182	1	PIATTELLO	COUELLE	TELLERSCHEIBE	PLATE	PLATILLO
8	9917892	1	MOLLA	RESSORT	FEDER	SPRING	RESORTE
9	9917888	1	MANICOTTO DI REGOLAZ.	MANCHON DE REGLAGE	SPANNSCHLOSS	ADJUSTMENT SLEEVE	TUERCA DE REGLAJE
10	9917887	1	PISTONCINO	PISTON	STOESSEL	PLUNGER	EMBOLO
11	9917889	1	ROSETTA PIANA	RONDELLE	SCHEIBE	WASHER	ARANDELA
12	9917886	1	MOLLA	RESSORT	FEDER	SPRING	RESORTE
13	9925951	1	COPERCHIO	COUVERCLE	DECKEL	COVER	TAPA
14	9929587	4	VITE	VIS	SCHRAUBE	SCREW	TORNILLO
15	9917897	2	PALETTA	AUBE	SCHAUFEL	BLADE	ALABE
16	9917987	1	GIRANTE	ROTOR	PUMPENRAD	IMPELLER	IMPULSOR
17	9917899	1	GUARNIZIONE	GARNITURE	DICHTUNG	GASKET	JUNTA
18	9917898	1	SEDE	SIEGE	SITZ	SEAT	ASIENTO
19	9917903	1	ANELLO DI TENUTA	JOINT D'ETANCHEITE	DICHTRING	SEAL	JUNTA HERMETICA
20	9917905	3	VALVOLA	SOUPAPE	VENTIL	VALVE	VALVULA
21	9920107	6	ROSETTA DI TENUTA	JOINT D'ETANCHEITE	DICHTRING	GASKET	JUNTA HERMETICA
22	9917904	3	RACCORDO	RACCORD	STUTZEN	CONNECTION	RACOR
23	9956300	2	PIASTRINA	PLAQUETTE	PLAETTCHEN	PLATE	PLACA
24	9917900	1	CORPO POMPA	CORPS DE POMPE	PUMPENGEHAUSE	PUMP HOUSING	CAJA BOMBA
25	9922902	1	ALBERO COMPLETO	ARBRE	WELLE	SHAFT	ARBOL
26	9917902	1	ROSETTA DI TENUTA	JOINT D'ETANCHEITE	DICHTRING	GASKET	JUNTA HERMETICA
27	9917901	1	PIATTELLO	COUELLE	TELLERSCHEIBE	PLATE	PLATILLO
28	9956254	1	PATTINO	PATIN	GLEITSTEIN	PAD	PATIN
29	9917914	2	VITE	VIS	SCHRAUBE	SCREW	TORNILLO
30	9922901	1	CAMMA	CAME	NOCKEN	CAM.	LEVA
31	9917916	1	ANELLO DI SICUREZZA	ARRETOIR	SICHERUNGSRING	LOCKRING	ANILLO DE FRENO
32	9927703	1	ANELLO DI APPOGGIO	BAGUE DE SUPPORT	STUETZRING	SUPPORT RING	ANILLO APOYO
33	9926919	1	MANICOTTO	MANCHON	MUFFE	SLEEVE	MANGUITO
34	9917921	1	ANELLO DI SICUREZZA	ARRETOIR	SICHERUNGSRING	LOCKRING	ANILLO DE FRENO
35	9923012	-	ROSETTA PIANA SP 2,05	RONDELLE	SCHEIBE	WASHER	ARANDELA
35	9922903	-	ROSETTA PIANA SP 2,18	RONDELLE	SCHEIBE	WASHER	ARANDELA

C80.50

01 02 03

POMPA INIEZIONE (C.A.V.)

Pompe d'injection
Einspritzpumpe

Injection Pump
Bomba de inyección

10.6/5

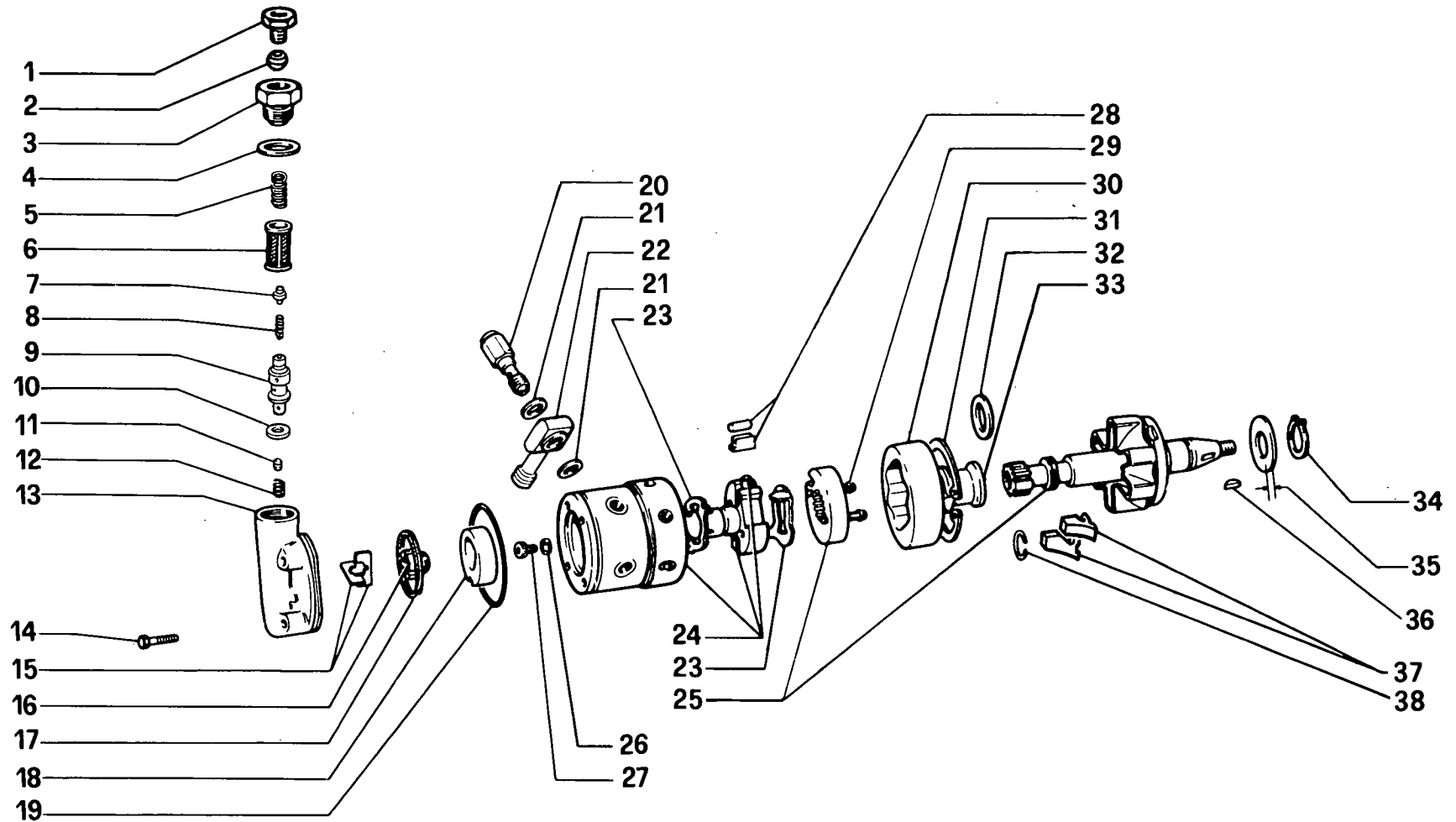

C80/50

POMPA INIEZIONE C.A.V.

10.06/05

(09-1981)

FIG	N. ORDINAZIONE	QTA	DENOMINAZIONE	DESIGNATION	BENENNUNG	DESCRIPTION	DENOMINACIONES
35	9922904	-	ROSETTA PIANA SP 2,31	RONDELLE	SCHEIBE	WASHER	ARANDELA
36	9917998	1	LINGUETTA	LINGUET	SCHEIBENFEDER	KEY	CHAVETA
37	9957819	4	MASSA CENTRIFUGA	MASSELOTTE	REGLERGEWICHT	FLYWEIGHT	CONTRAPESO REGULAD
38	9917991	1	ANELLO DI SICUREZZA	ARRETOIR	SICHERUNGSRING	LOCKRING	ANILLO DE FRENO

CEB.50

01 02 03

POMPA ALIMENTAZIONE

Pompe d'alimentation
Kraftstoffpumpe

Fuel Pump
Bomba de alimentación

10.6/6

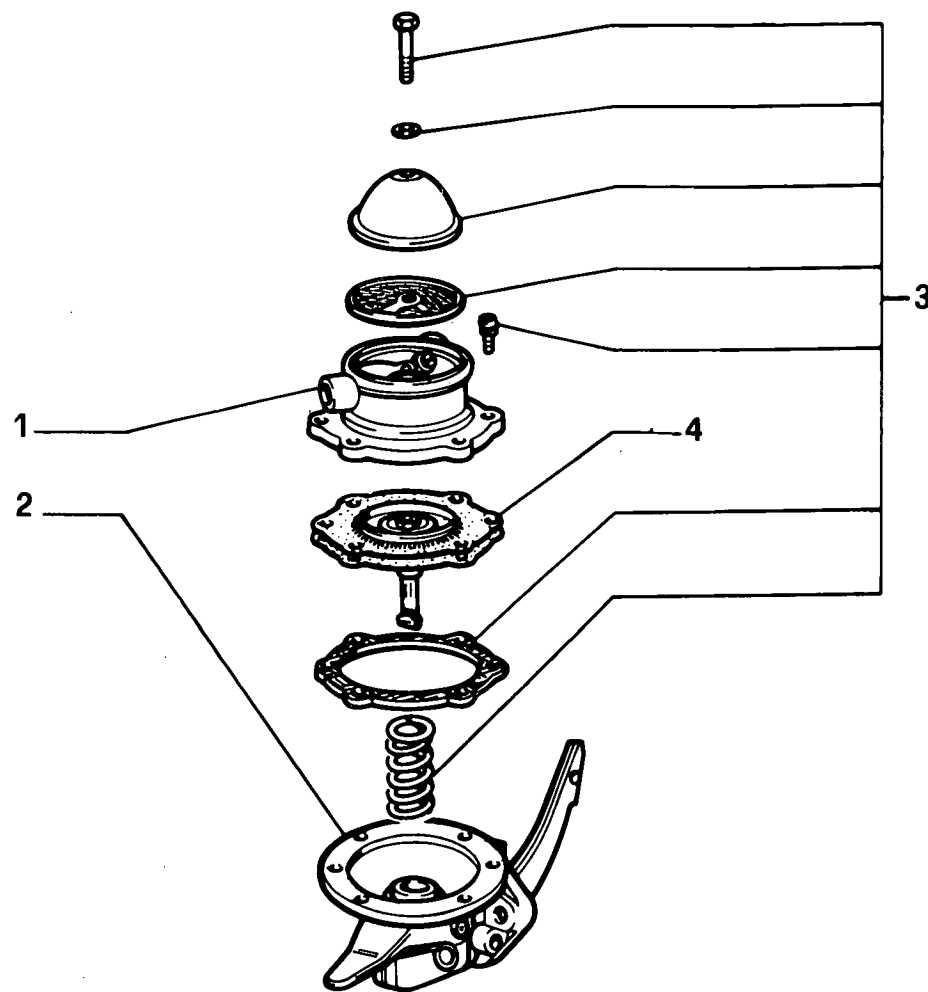

C80/50

POMPA DI ALIMENTAZIONE

10.06/06

(09-1981)

FIG	N. ORDINAZIONE	QTA	DENOMINAZIONE	DESIGNATION	BENENNUNG	DESCRIPTION	DENOMINACIONES
1	9927918	1	CORPO SUPERIORE	CORPS	GEHAUSE	BODY	CUERPO
2	9957842	1	CORPO INFERIORE	CORPS	GEHAUSE	BODY	CUERPO
3	9927920	1	CORREDO	EQUIPEMENT	SATZ	KIT	JUEGO
4	9924369	1	MEMBRANA	MEMBRANE	MEMBRAN	DIAPHRAGM	MEMBRANA

FILTRO COMBUSTIBILE

Filtre à combustible
Kraftstofffilter

Fuel Filter
Filtro de combustible

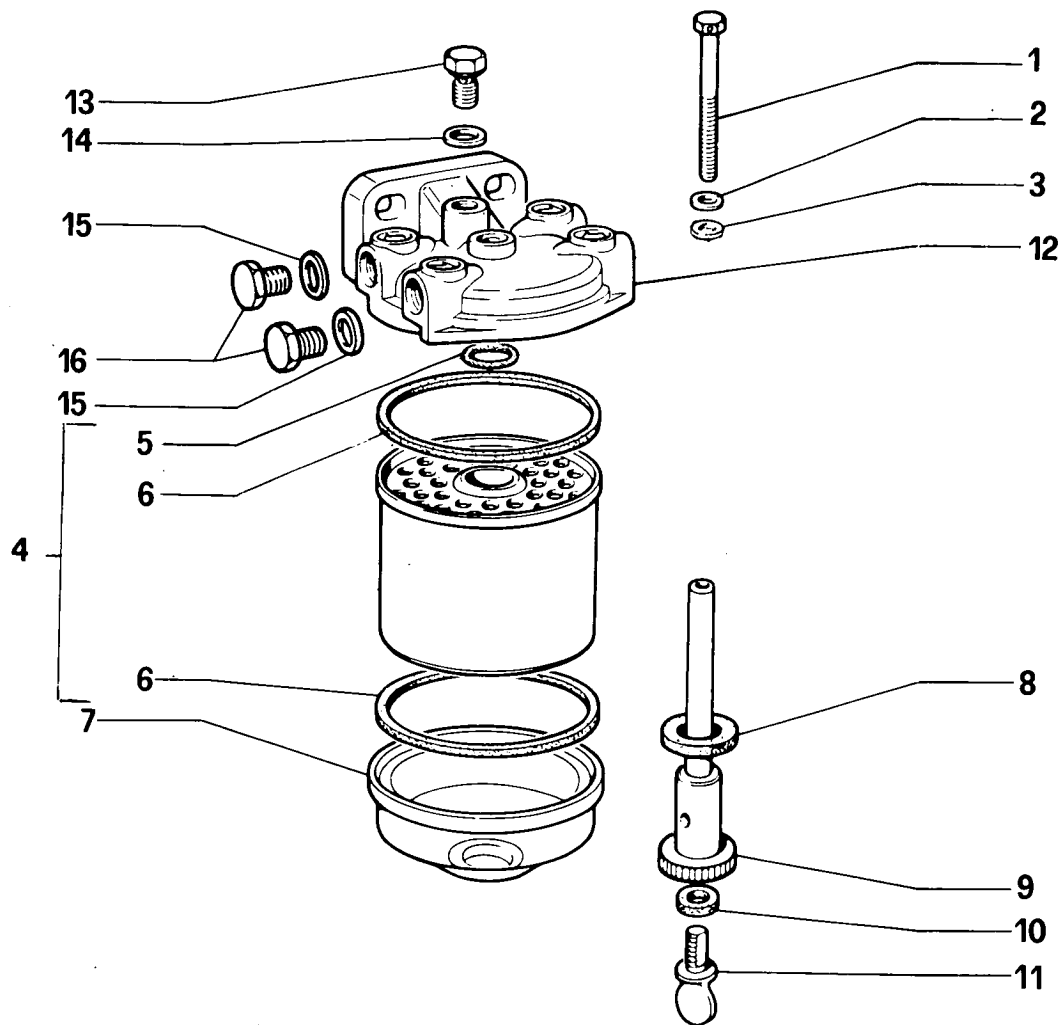

C80/50

FILTRO COMBUSTIBILE

10.06/07

(09-1981)

FIG	N. ORDINAZIONE	QTA	DENOMINAZIONE	DESIGNATION	BENENNUNG	DESCRIPTION	DENOMINACIONES
1	9918385	1	VITE	VIS	SCHRAUBE	SCREW	TORNILLO
2	9927911	1	ROSETTA DI SICUREZZA	RONDELLE FREIN	SICHERUNGSRING	LOCKWASHER	ARANDELA DE FRENO
3	9917950	1	ANELLO DI TENUTA	JOINT D'ETANCHEITE	DICHTRING	SEAL	JUNTA HERMETICA
4	4621740	1	CORREDO	EQUIPEMENT	SATZ	KIT	JUEGO
5	9918105	1	ANELLO OR	BAGUE TORIQUE	O-RING	O-SEAL	ANILLO O.
6	9918103	2	GUARNIZIONE DI TENUTA	JOINT	DICHTUNG	GASKET	JUNTA
7	9918123	1	VASCHETTA FILTRO	CUVE	GLOCKE	BOWL	TAZA
8	9918124	1	GUARNIZIONE	GARNITURE	DICHTUNG	GASKET	JUNTA
9	9919164	1	COLONNETTA	COLONNETTE	BOLZEN	STUD	ESPARRAGO
10	9918145	1	GUARNIZIONE	GARNITURE	DICHTUNG	GASKET	JUNTA
11	9918125	1	VITE	VIS	SCHRAUBE	SCREW	TORNILLO
12	9927916	1	SUPPORTO FILTRO	SUPPORT	LAGER	SUPPORT	SOPORTE
13	9918110	2	TAPPO	BOUCHON	STOPFEN	PLUG	TAPON
14	9918107	2	ROSETTA PIANA	RONDELLE	SCHEIBE	WASHER	ARANDELA
15	9918111	2	TAPPO	BOUCHON	STOPFEN	PLUG	TAPON
16	9918104	2	GUARNIZIONE	GARNITURE	DICHTUNG	GASKET	JUNTA

CEB.50

01 02 03

FILTRO COMBUSTIBILE

(C.A.V.)

10.6/8

Filtre à combustible
Kraftstofffilter

Fuel Filter
Filtro de combustible

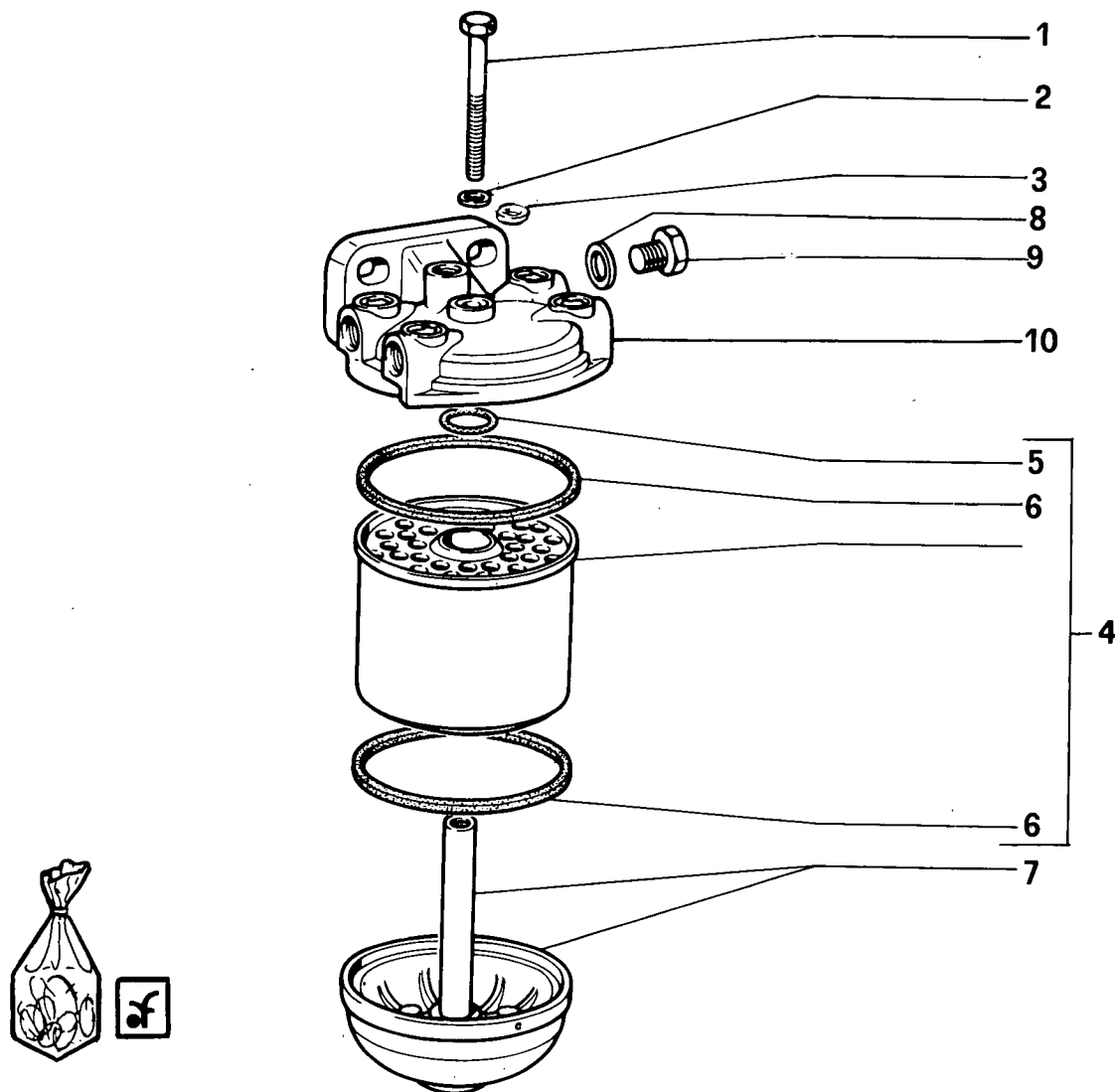

C80/50

FILTRO COMBUSTIBILE

10.06/08

(09-1981)

FIG	N. ORDINAZIONE	QTA	DENOMINAZIONE	DESIGNATION	BENENNUNG	DESCRIPTION	DENOMINACIONES
1	9918385	1	VITE	VIS	SCHRAUBE	SCREW	TORNILLO
2	9927911	1	ROSETTA DI SICUREZZA	RONDELLE FREIN	SICHERUNGSRING	LOCKWASHER	ARANDELA DE FRENO
3	9917950	1	ANELLO DI TENUTA	JOINT D'ETANCHEITE	DICHTRING	SEAL	JUNTA HERMETICA
4	4621740	2	CORREDO	EQUIPEMENT	SATZ	KIT	JUEGO
5	9918105	1	ANELLO OR	BAGUE TORIQUE	O-RING	O-SEAL	ANILLO O.
6	9918103	2	GUARNIZIONE DI TENUTA	JOINT	DICHTUNG	GASKET	JUNTA
7	9918386	1	VASCHETTA FILTRO	CUVE	GLOCKE	BOWL	TAZA
8	9918104	2	GUARNIZIONE	GARNITURE	DICHTUNG	GASKET	JUNTA
9	9918111	2	TAPPO	BOUCHON	STOPFEN	PLUG	TAPON
10	9927916	1	SUPPORTO FILTRO	SUPPORT	LAGER	SUPPORT	SOPORTE

C80.50

01 02 03

PORTAPOLVERIZZATORE

Porte-injecteur
Düsenhalter

Nozzle Holder
Portainyector

10.6/9

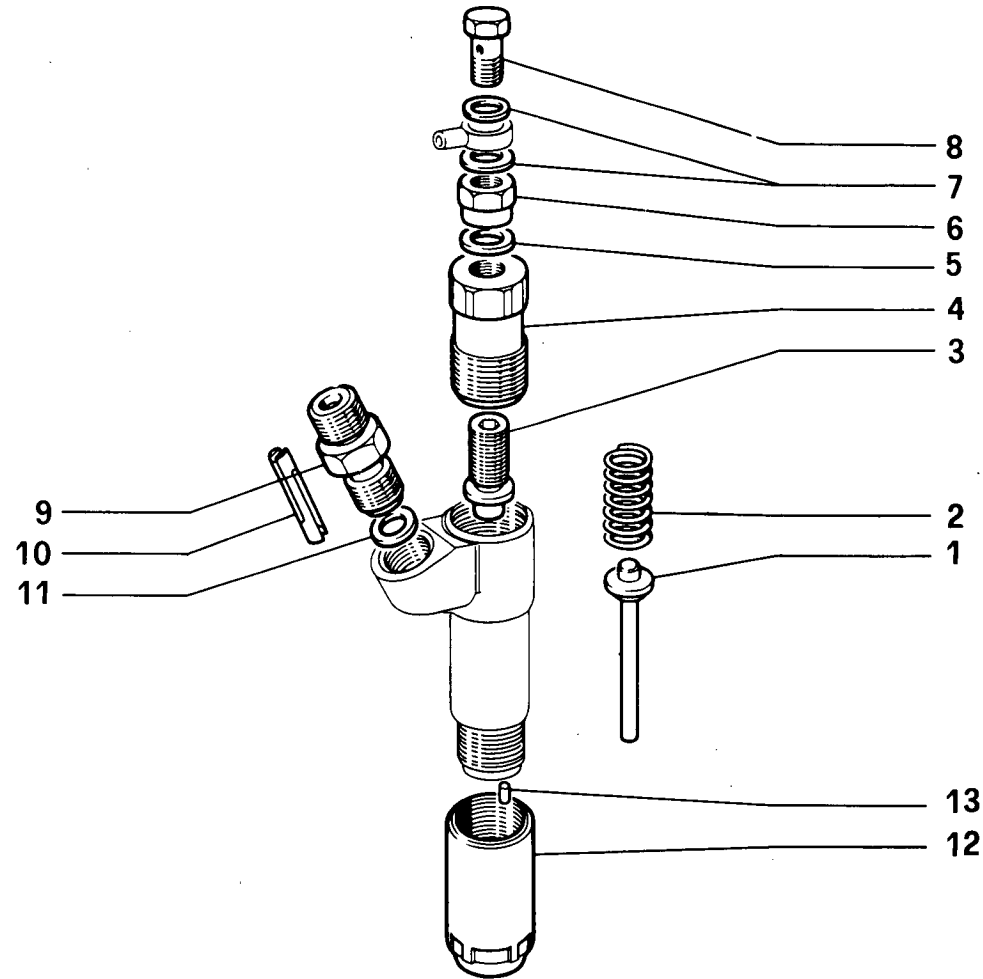

C80/50

PORTAPOLVERIZZATORE

10.06/09

(09-1981)

FIG	N. ORDINAZIONE	QTA	DENOMINAZIONE	DESIGNATION	BENENNUNG	DESCRIPTION	DENOMINACIONES
1	767110	1	ASTA	TIGE	STANGE	ROD	VARILLA
2	656829	1	MOLLA	RESSORT	FEDER	SPRING	RESORTE
3	766839	1	VITE DI REGOLAZIONE	VIS DE REGLAGE	EINSTELL SCHRAUBE	ADJ/SCREW	TORNILLO DE REGLAJE
4	766838	1	TAPPO	BOUCHON	STOPFEN	PLUG	TAPON
5	726381	1	ROSETTA PIANA	RONDELLE	SCHEIBE	WASHER	ARANDELA
6	766837	1	DADO	ECROU	MUTTER	NUT	TUERCA
7	722023	2	GUARNIZIONE	GARNITURE	DICHTUNG	GASKET	JUNTA
8	767451	1	BOCCHETTONE	VIS-RACCORD	HOLHLSCHRAUBE	UNION	BOQUILLA
9	771163	1	RACCORDO	RACCORD	STUTZEN	CONNECTION	RACOR
10	766193	1	FILTRO A BARRETTA	FILTRE	FILTER	FILTER	FILTRO
11	722027	1	ROSETTA PIANA	RONDELLE	SCHEIBE	WASHER	ARANDELA
12	767112	1	DADO	ECROU	MUTTER	NUT	TUERCA
13	768378	2	GRANO	ERGOT	PASSTIFT	DOWEL	PITON

CEB.50

01 02 03

PORTAPOLVERIZZATORE C.A.V.

Porte-injecteur
Düsenhalter

Nozzle Holder
Portainyector

10.6/10

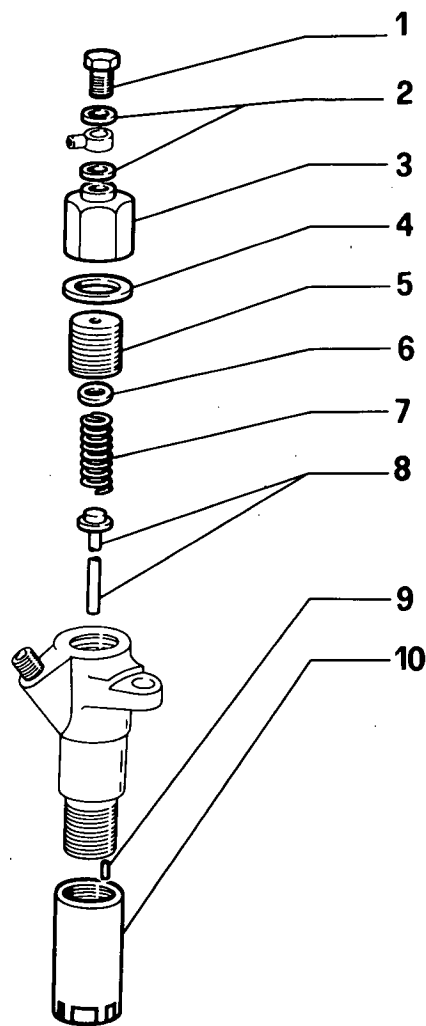

C80/50

PORTAPOLVERIZZATORE C,A.V.

10.06/10

(09-1981)

FIG	N. ORDINAZIONE	QTA	DENOMINAZIONE	DESIGNATION	BENENNUNG	DESCRIPTION	DENOMINACIONES
1	9928367	1	RACCORDO	RACCORD	STUTZEN	CONNECTION	RACOR
2	9928396	2	GUARNIZIONE	GARNITURE	DICHTUNG	GASKET	JUNTA
3	9928374	1	GHIERA	VIROLE	GEWINDERING	PLUG	VIROLA
4	9928366	1	ROSETTA DI TENUTA	JOINT D'ETANCHEITE	DICHTRING	GASKET	JUNTA HERMETICA
5	9928371	1	GHIERA	VIROLE	GEWINDERING	PLUG	VIROLA
6	9928369	1	DISTANZIALE	ENTRETOISE	ABSTANDSTUECK	SPACER	SEPARADOR
7	9928370	1	MOLLA	RESSORT	FEDER	SPRING	RESORTE
8	9928375	1	ASTA	TIGE	STANGE	ROD	VARILLA
9	9928376	2	SPINA	GOUPILLE	STIFT	PIN	PASADOR
10	9928373	1	GHIERA	VIROLE	GEWINDERING	PLUG	VIROLA

CEB.50

01 02 03

PORTAPOLVERIZZATORE

Porte-injecteur
Düsenhalter

Nozzle Holder
Portainyector

10.6/11

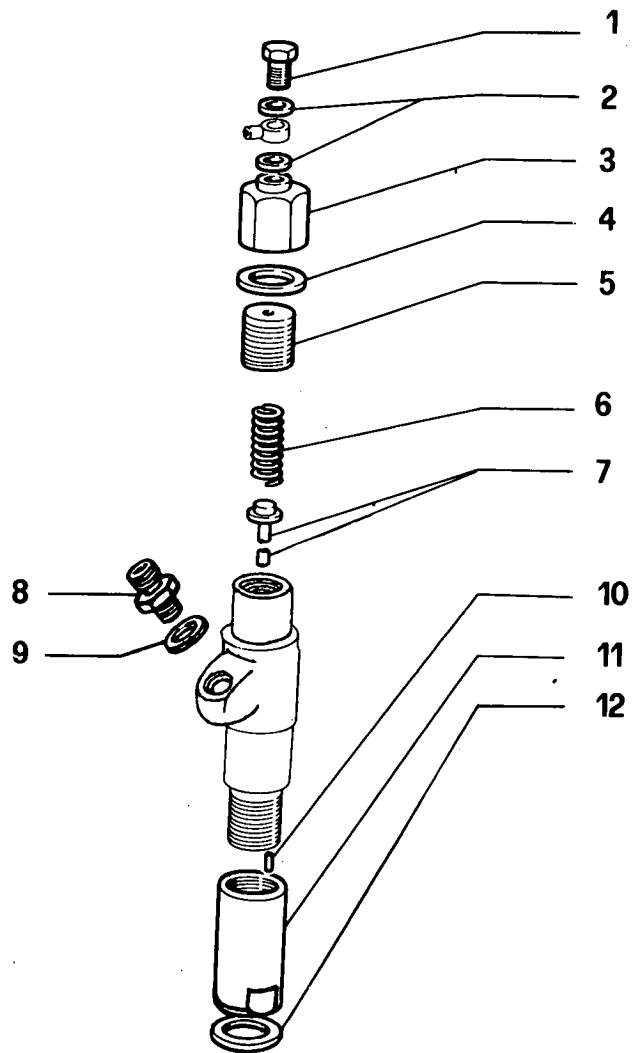

C80/50

PORTAPOLVERIZZATORE OMAP

10.06/11

(09-1981)

FIG	N. ORDINAZIONE	QTA	DENOMINAZIONE	DESIGNATION	BENENNUNG	DESCRIPTION	DENOMINACIONES
1	9928392	1	RACCORDO	RACCORD	STUTZEN	CONNECTION	RACOR
2	9928391	2	GUARNIZIONE	GARNITURE	DICHTUNG	GASKET	JUNTA
3	9930022	1	RACCORDO	RACCORD	STUTZEN	CONNECTION	RACOR
4	9930025	1	GUARNIZIONE	GARNITURE	DICHTUNG	GASKET	JUNTA
5	9930024	1	VITE	VIS	SCHRAUBE	SCREW	TORNILLO
6	9930019	1	MOLLA	RESSORT	FEDER	SPRING	RESORTE
7	9930026	1	ASTA	TIGE	STANGE	ROD	VARILLA
8	9930023	1	BOCCHETTONE	VIS-RACCORD	HOLHLSCHRAUBE	UNION	BOQUILLA
9	9930027	1	GUARNIZIONE	GARNITURE	DICHTUNG	GASKET	JUNTA
10	9931247	2	SPINA	GOUPILLE	STIFT	PIN	PASADOR
11	9930021	1	GHIERA	VIROLE	GEWINDERING	PLUG	VIROLA
12	9930020	1	ROSETTA PIANA	RONDELLE	SCHEIBE	WASHER	ARANDELA

Radiateur
Kühler

Radiator
Radiador

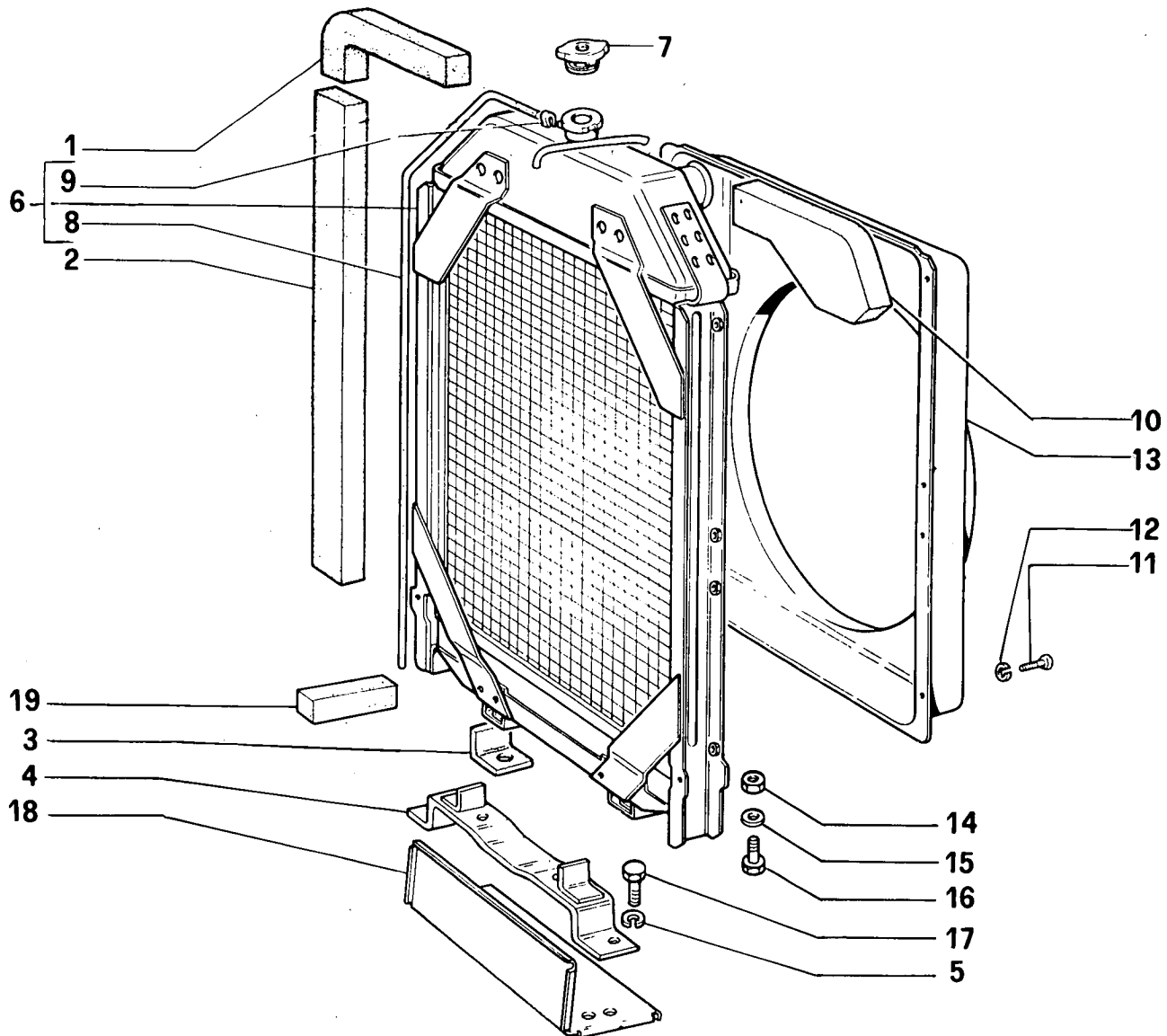

C80/50

RADIATORE

10.07/01

(09-1981)

FIG	N. ORDINAZIONE	QTA	DENOMINAZIONE	DESIGNATION	BENENNUNG	DESCRIPTION	DENOMINACIONES
1	4950002	1	PROTEZIONE SUP. DX	PROTECTION	ABDECKUNG	SHIELD	DEFENSA
2	4953953	2	PROTEZIONE LATERALE	PROTECTION	ABDECKUNG	SHIELD	DEFENSA
3	594762	2	TASSELLO ELASTICO	TAMPON	GUMMISTUECK	PAD	ALMOHADILLA
4	4950882	1	STAFFA	ETRIER	HALTER	BRACKET	SOPORTE
5	10517070	2	ROSETTA DI SICUREZZA	RONDELLE FREIN	SICHERUNGSRING	LOCKWASHER	ARANDELA DE FRENO
6	4970998	1	RADIATORE COMPLETO	RADIATEUR	KUEHLER	RADIATOR	RADIADOR
6	4952473	1	RADIATORE COMPL.-171-	RADIATEUR	KUEHLER	RADIATOR	RADIADOR
7	590054	1	TAPPO	BOUCHON	STOPFEN	PLUG	TAPON
8	4953838	1	TUBO DI SFIATO	TUBE DE DESAERAGE	ENTLUEFTUNGSROHR	BREATHER PIPE	TUBO PRG. AIRE
9	596747	3	FERMAGLIO	AGRAFE	KLEMMSTUECK	CLIP	SUJETADOR
10	4950003	1	PROTEZIONE SUP. SX	PROTECTION	ABDECKUNG	SHIELD	DEFENSA
11	10902011	6	VITE	VIS	SCHRAUBE	SCREW	TORNILLO
12	10516470	6	ROSETTA DI SICUREZZA	RONDELLE FREIN	SICHERUNGSRING	LOCKWASHER	ARANDELA DE FRENO
13	4970999	1	CONVOGLIATORE	CONVOYEUR	LEITBLECH	CONVEYOR	CANALIZADOR
14	12574511	2	DADO	ECROU	MUTTER	NUT	TUERCA
15	12638601	2	ROSETTA PIANA	RONDELLE	SCHEIBE	WASHER	ARANDELA
16	11306921	2	VITE	VIS	SCHRAUBE	SCREW	TORNILLO
17	15540321	2	VITE	VIS	SCHRAUBE	SCREW	TORNILLO
18	4950177	1	RIPARO	PROTECTION	ABDECKUNG	PROTECTION	DEFENSA
19	4950005	1	PROTEZIONE INF.	PROTECTION	ABDECKUNG	SHIELD	DEFENSA

POMPA ACQUA E TUBAZIONI

Pompe et canalisations d'eau
Wasserpumpe und Leitungen

Water Pump and Lines
Bomba de agua y tuberías

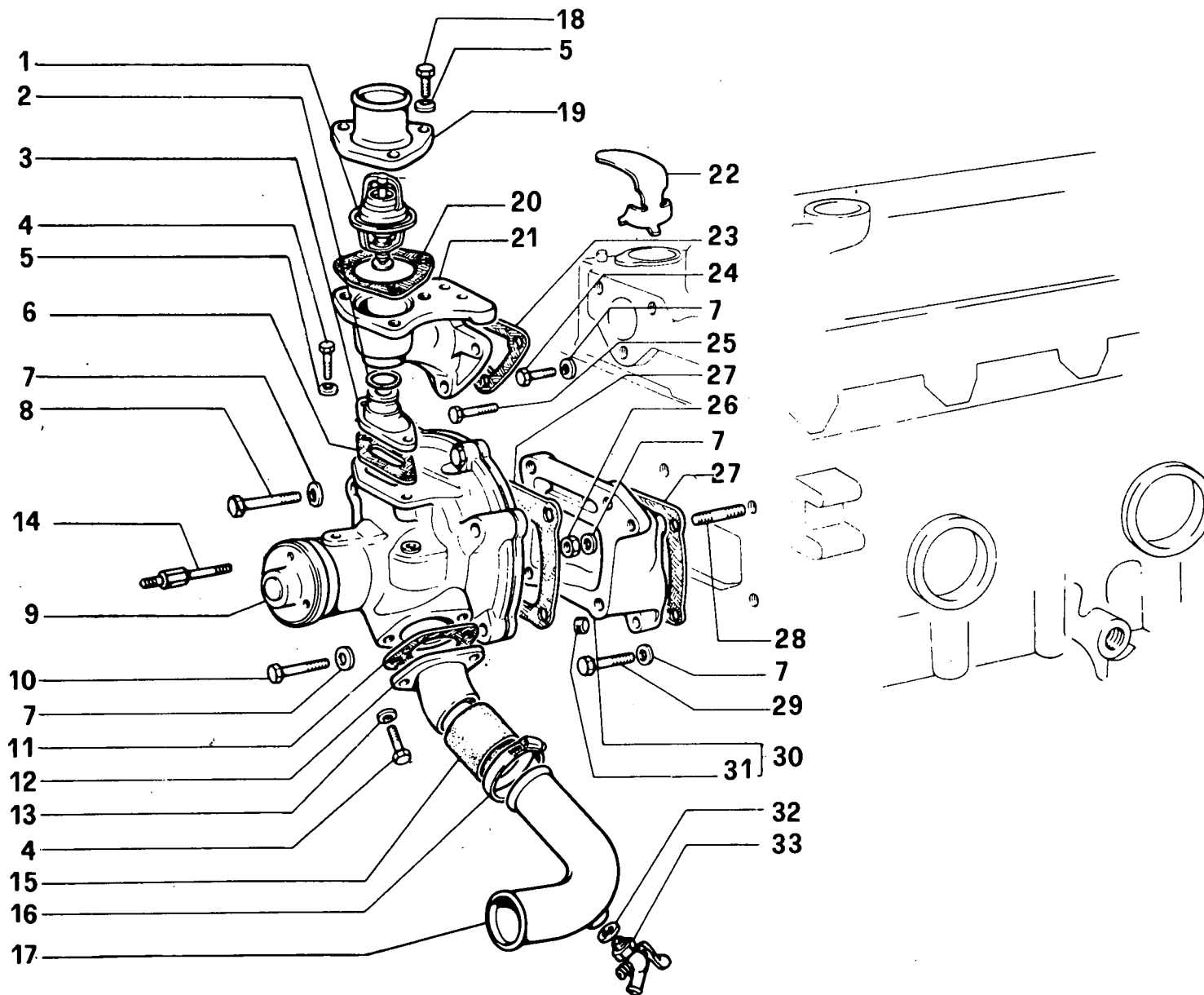

C80/50

POMPA ACQUA E TUBAZIONI

10.07/02

(09-1981)

FIG	N. ORDINAZIONE	QTA	DENOMINAZIONE	DESIGNATION	BENENNUNG	DESCRIPTION	DENOMINACIONES
1	4703088	1	TERMOSTATO	THERMOSTAT	THERMOSTAT	THERMOSTAT	TERMOSTATO
2	14462882	1	ANELLO OR	BAGUE TORIQUE	O-RING	O-SEAL	ANILLO O.
3	4673807	1	TUBO	TUBE/TUYAU	ROHR	PIPE/TUBE	TUBO
4	16043421	4	VITE	VIS	SCHRAUBE	SCREW	TORNILLO
5	11198071	4	ROSETTA DI SICUREZZA	RONDELLE FREIN	SICHERUNGSRING	LOCKWASHER	ARANDELA DE FRENO
6	4673810	1	GUARNIZIONE	GARNITURE	DICHTUNG	GASKET	JUNTA
7	11198371	11	ROSETTA DI SICUREZZA	RONDELLE FREIN	SICHERUNGSRING	LOCKWASHER	ARANDELA DE FRENO
8	15888721	3	VITE	VIS	SCHRAUBE	SCREW	TORNILLO
9	4679242	1	POMPA ACQUA	POMPE A EAU	WASSERPUMPE	WATER PUMP	BOMBA DE AGUA
10	15970921	1	VITE	VIS	SCHRAUBE	SCREW	TORNILLO
11	4599562	1	GUARNIZIONE	GARNITURE	DICHTUNG	GASKET	JUNTA
12	4697838	1	TUBO	TUBE/TUYAU	ROHR	PIPE/TUBE	TUBO
13	10519621	2	ROSETTA DI SICUREZZA	RONDELLE FREIN	SICHERUNGSRING	LOCKWASHER	ARANDELA DE FRENO
14	4702455	1	VITE	VIS	SCHRAUBE	SCREW	TORNILLO
15	596152	2	MANICOTTO USCITA	MANCHON	MUFFE	SLEEVE	MANGUITO
16	12174090	4	COLLARE	COLLIER	SHELLE	COLLAR	COLLAR
17	4956119	1	TUBO USCITA	TUBE/TUYAU	ROHR	PIPE/TUBE	TUBO
18	16043621	3	VITE	VIS	SCHRAUBE	SCREW	TORNILLO
19	4661543	1	TUBO USCITA ACQUA	TUBE/TUYAU	ROHR	PIPE/TUBE	TUBO
20	4599809	1	GUARNIZIONE	GARNITURE	DICHTUNG	GASKET	JUNTA
21	4671017	1	BOCCHETTONE	VIS-RACCORD	HOLHLSCHRAUBE	UNION	BOQUILLA
22	4601060	1	DEFLETTORE	DEFLECTEUR	ABWEISER	DEFLECTOR	DEFLECTOR
23	4604615	1	GUARNIZIONE	GARNITURE	DICHTUNG	GASKET	JUNTA
24	11307021	2	VITE	VIS	SCHRAUBE	SCREW	TORNILLO
25	15970721	1	VITE	VIS	SCHRAUBE	SCREW	TORNILLO
26	12164740	1	DADO	ECROU	MUTTER	NUT	TUERCA
27	4599561	2	GUARNIZIONE	GARNITURE	DICHTUNG	GASKET	JUNTA
28	13449910	1	PRIGIONIERO	GOUJON	STIFTSCHRAUBE	STUD	ESPARRAGO
29	11234721	1	VITE	VIS	SCHRAUBE	SCREW	TORNILLO
30	4647958	1	SUPPORTO POMPA	PORTE-POMPE	PUMPENTRAEGER	PUMP BRACKET	PORTA-BOMBA
31	14325701	1	TAPPO	BOUCHON	STOPFEN	PLUG	TAPON
32	10278660	1	GUARNIZIONE	GARNITURE	DICHTUNG	GASKET	JUNTA
33	5118499	1	RUBINETTO	ROBINET	HARN	COCK	GRIFO

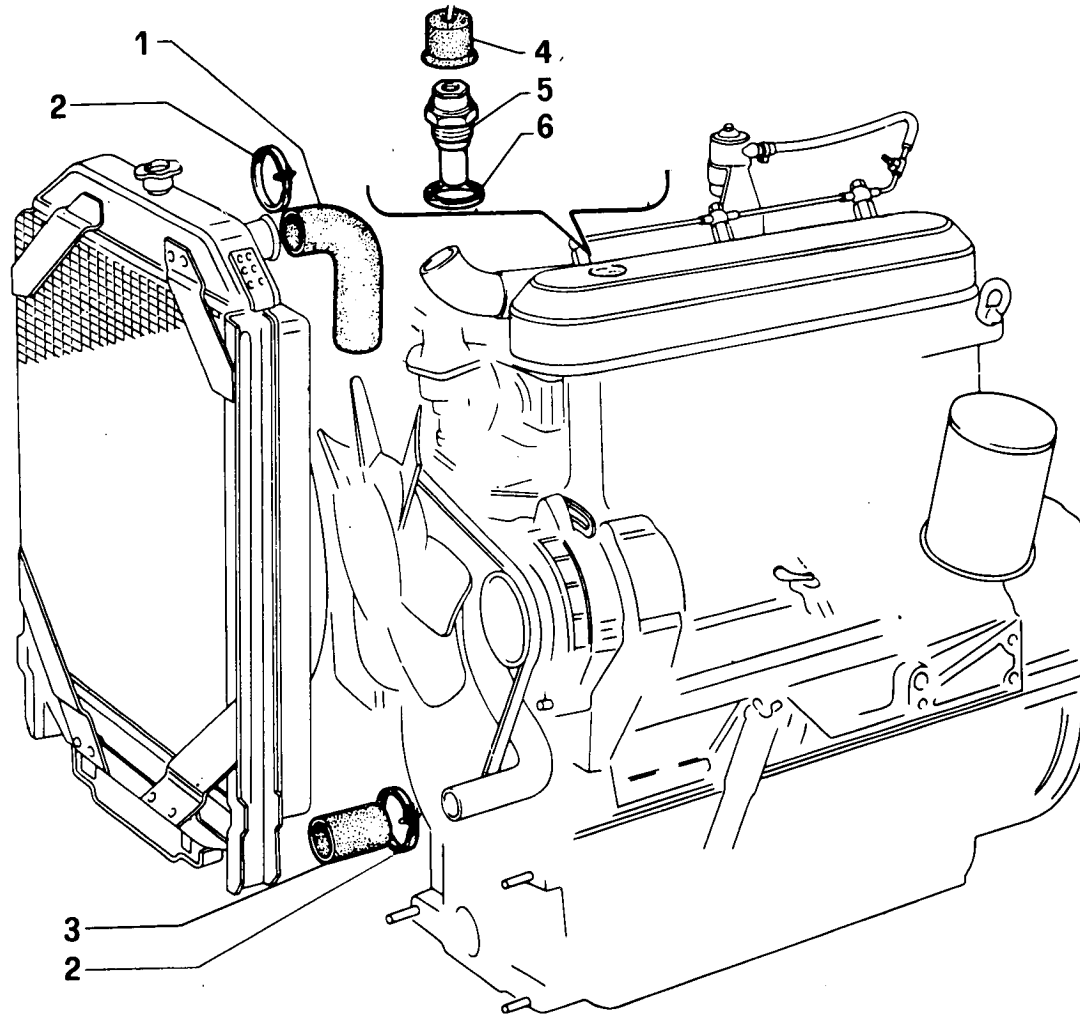

C80/50

POMPA ACQUA E TUBAZIONI

10.07/03

(09-1981)

FIG	N. ORDINAZIONE	QTA	DENOMINAZIONE	DESIGNATION	BENENNUNG	DESCRIPTION	DENOMINACIONES
1	4953958	1	MANICOTTO	MANCHON	MUFFE	SLEEVE	MANGUITO
2	12174790	2	FASCETTA	COLLIER	HALTEBAND	STRAP	ABRAZADERA
3	596152	1	MANICOTTO	MANCHON	MUFFE	SLEEVE	MANGUITO
4	5108206	1	CAPPUCCIO	CAPUCHON	STAUBSCHUTZKAPPE	BOOT	CAPUCHON
5	4988618	1	TRASMETTITORE TEMP. ACQUA	CONTACTEUR	KONTAKTGEBER	SENDING UNIT	CONTACTOR
6	4988619	1	GUARNIZIONE	GARNITURE	DICHTUNG	GASKET	JUNTA

C80.50

01 02 03

POMPA ACQUA

*Pompe à eau
Wasserpumpe*

*Water Pump
Bomba de agua*

10.7/4

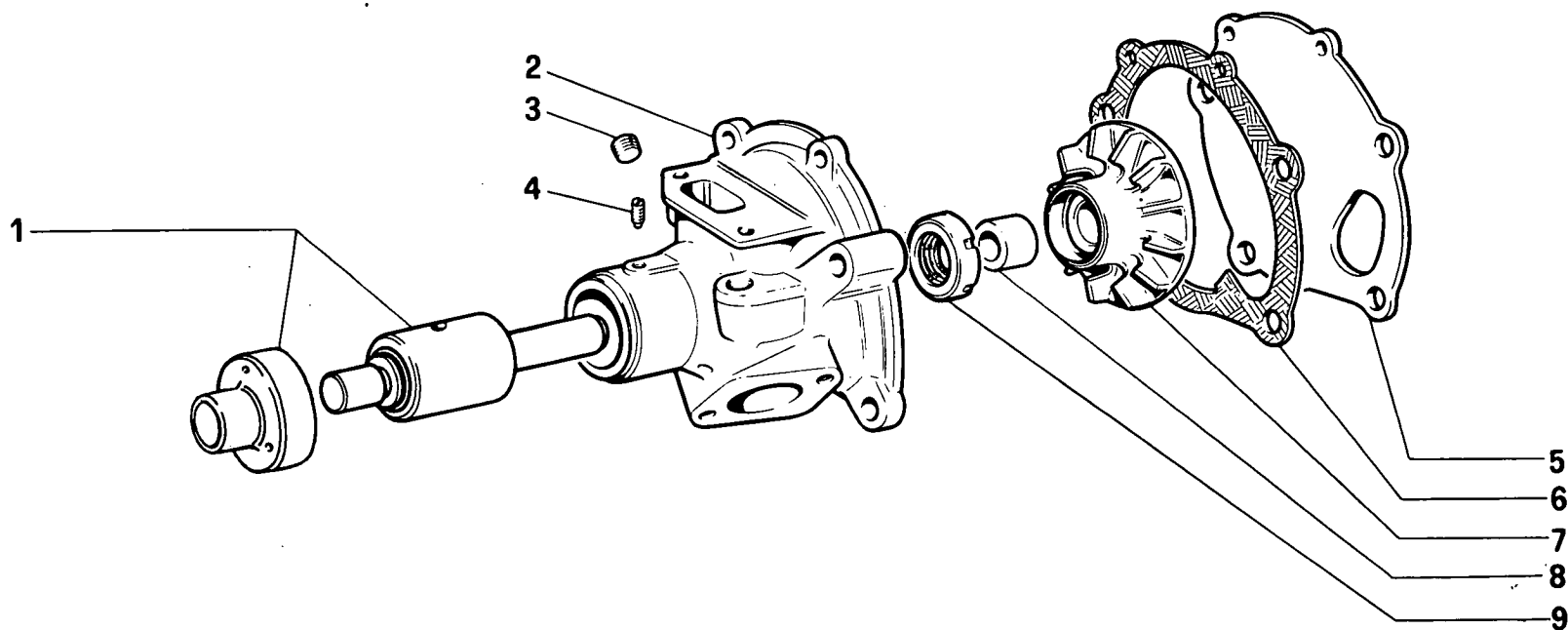

C80/50

POMPA ACQUA

10.07/04

(09-1981)

FIG	N. ORDINAZIONE	QTA	DENOMINAZIONE	DESIGNATION	BENENNUNG	DESCRIPTION	DENOMINACIONES
1	4679242 4655011	1 1	POMPA ACQUA COMPLETA ALBERO POMPA ACQUA COMPLETO	POMPE A EAU ARBRE POMPE A EAU	WASSERPUMPE WASSERPUMPENWELLE	WATER PUMP PUMP SHAFT	BOMBA DE AGUA EJE BOMBA AGUA
2	4603862	1	CORPO POMPA ACQUA	CORPS DE POMPE	PUMPENGEHAUSE	PUMP HOUSING	CAJA BOMBA
3	14325001	2	TAPPO	BOUCHON	STOPFEN	PLUG	TAPON
4	13748610	1	VITE	VIS	SCHRAUBE	SCREW	TORNILLO
5	4599557	1	COPERCHIO	COUVERCLE	DECKEL	COVER	TAPA
6	4599560	1	GUARNIZIONE	GARNITURE	DICHTUNG	GASKET	JUNTA
7	4639097	1	GIRANTE	ROTOR	PUMPENRAD	IMPELLER	IMPULSOR
8	4639096	1	BOCCOLA	DOUILLE	BUECHSE	BUSH	CASQUILLO
9	4603870	1	ANELLO DI TENUTA	JOINT D'ETANCHEITE	DICHTRING	SEAL	JUNTA HERMETICA

VENTILATORE E SUO COMANDO

Ventilateur et sa commande
Lüfter und Lüfterantrieb

Fan and Fan Drive
Ventilador y su mando

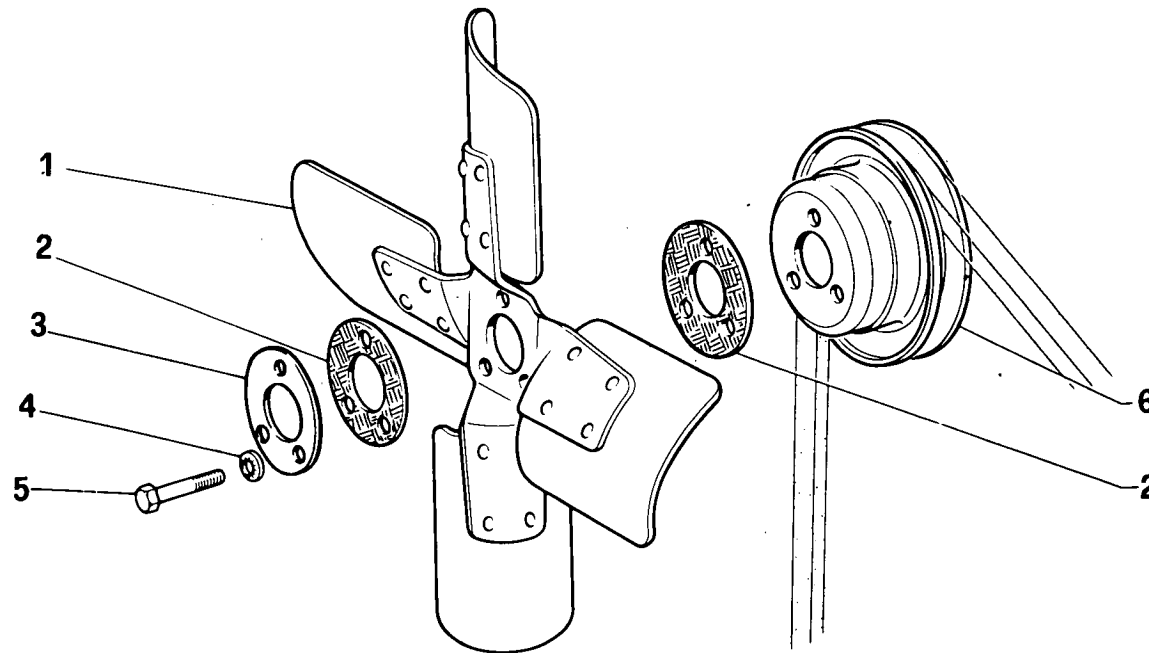

C80/50

VENTILATORE E SUO COMANDO

10.07/05

(09-1981)

FIG	N. ORDINAZIONE	QTA	DENOMINAZIONE	DESIGNATION	BENENNUNG	DESCRIPTION	DENOMINACIONES
1	4714777	1	VENTOLA	SOUFFLERIE	GEBLAESE	BLOWER	VENTILADOR
2	574526	2	RONDELLA APPOGGIO	RONDELLE	TOPFSCHIEBE	CUP	PLATO DE COPA
3	4584861	1	RONDELLA	RONDELLE	TOPFSCHIEBE	CUP	PLATO DE COPA
4	11198071	3	ROSETTA DI SICUREZZA	RONDELLE FREIN	SICHERUNGSRING	LOCKWASHER	ARANDELA DE FRENO
5	16043421	3	VITE	VIS	SCHRAUBE	SCREW	TORNILLO
6	4655014	1	PULEGGIA CONDOTTA	POULIE ENTRAINEE	RIEMENSCHIEBE GETRIEBEN	DRIVEN PULLEY	POLEA CONDUCCIDA

VENTILATORE E SUO COMANDO

Ventilateur et sa commande
Lüfter und Lüfterantrieb

Fan and Fan Drive
Ventilador y su mando

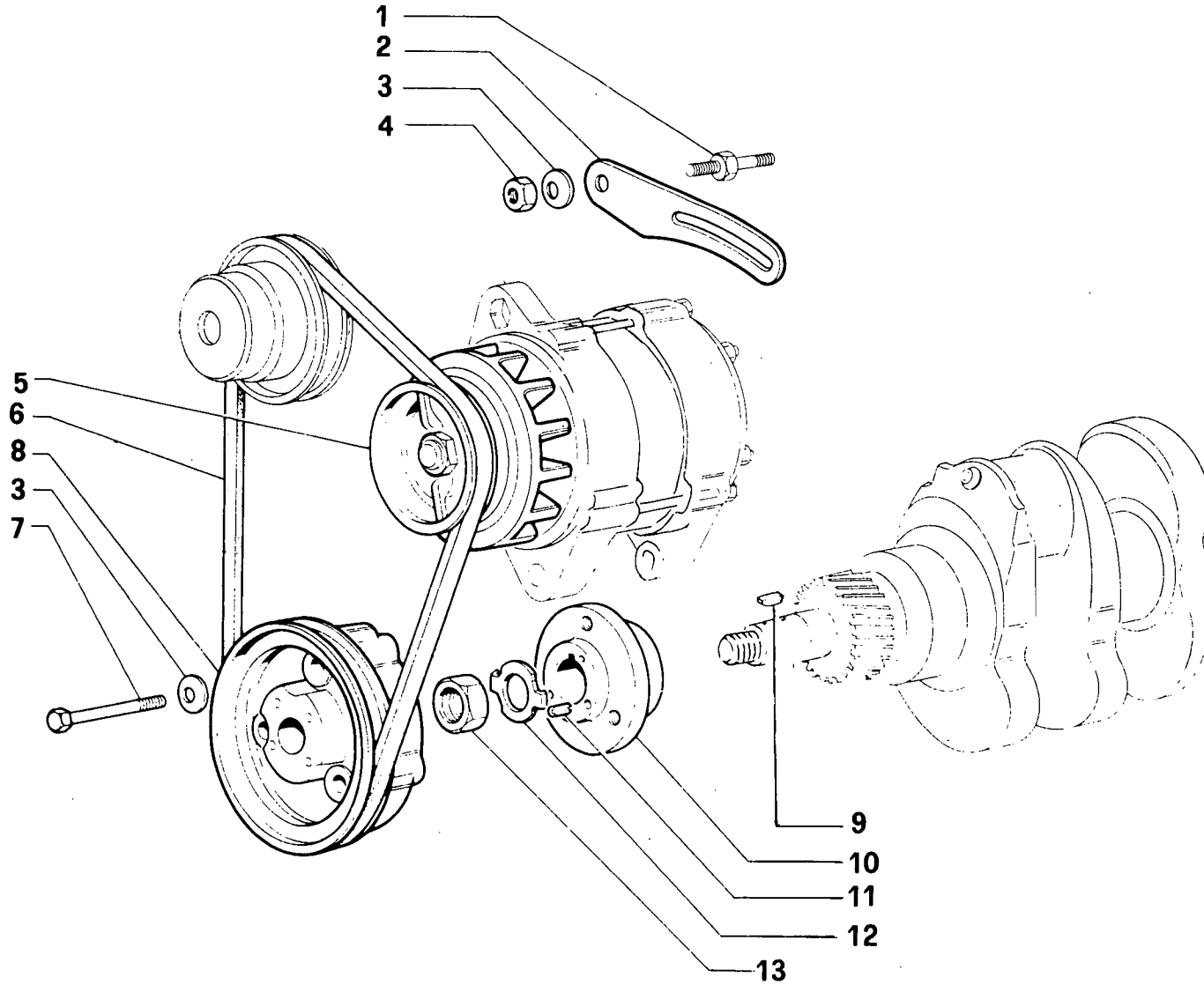

C80/50

VENTILATORE E SUO COMANDO

10.07/06

(09-1981)

FIG	N. ORDINAZIONE	QTA	DENOMINAZIONE	DESIGNATION	BENENNUNG	DESCRIPTION	DENOMINACIONES
1	4702455	1	VITE	VIS	SCHRAUBE	SCREW	TORNILLO
2	4702454	1	TENDITORE	TENDEUR	SPANNER	TENSIONER	TENSOR
3	11198371	4	ROSETTA DI SICUREZZA	RONDELLE FREIN	SICHERUNGSRING	LOCKWASHER	ARANDELA DE FRENO
4	12164711	1	DADO	ECROU	MUTTER	NUT	TUERCA
5	4702548	1	PULEGGIA CONDOTTA	POULIE ENTRAINEE	RIEMENSCHLEIBE GETRIEBEN	DRIVEN PULLEY	POLEA CONDUCTIDA
6	4624737	1	CINGHIA	COURROIES	RIEMEN	BELTS	CORREAS
7	15888721	3	VITE	VIS	SCHRAUBE	SCREW	TORNILLO
8	4666429	1	PULEGGIA CONDUTTRICE	POULIE ENTRAINEUSE	RIEMENSCHLEIBE TRIEBEND	DRIVING PULLEY	POLEA CONDUCTORA
9	4606664	1	LINGUETTA	LINGUET	SCHEIBENFEDER	KEY	CHAVETA
10	4622324	1	MOZZO PULEGGIA	MOYEU	NABE	HUB	FUJE
11	14165470	1	SPINA	GOUPILLE	STIFT	PIN	PASADOR
12	4600190	1	PIASTRINA DI SICUREZZA	PLAQUETTE FREIN	SICHERUNGSBLECH	LOCKPLATE	PLACA DE FRENO
13	4600189	1	DADO	ECROU	MUTTER	NUT	TUERCA

DISPOSITIVI PER AVVIAMENTO A BASSA TEMPERATURA

Dispositifs pour démarrage par basse température

Anlassvorrichtung bei tiefer Temperatur

Low Temperature Starting Aids

Dispositivos para el arranque en tiempo frío

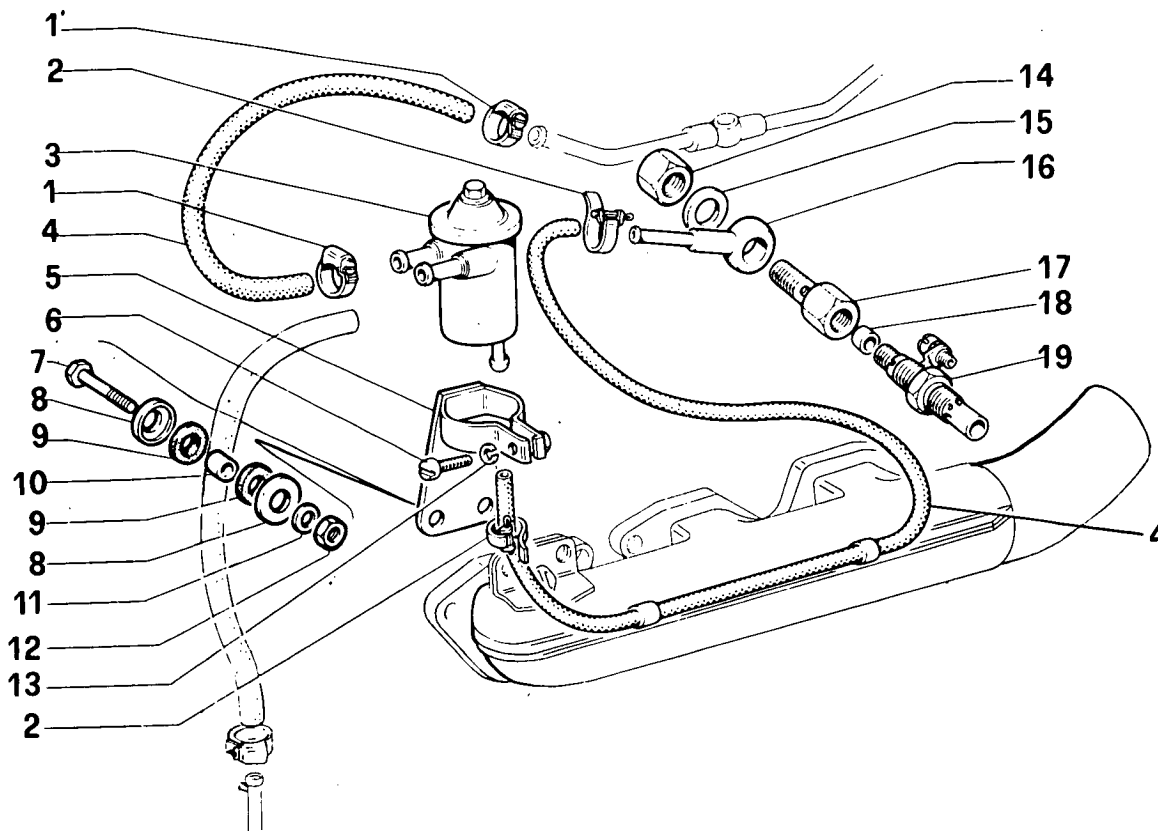

C80/50

DISPOSITIVI PER AVVIAMENTO BASSA TEMP.

10.08/01

(09-1981)

FIG	N. ORDINAZIONE	QTA	DENOMINAZIONE	DESIGNATION	BENENNUNG	DESCRIPTION	DENOMINACIONES
1	12179490	2	COLLARE	COLLIER	SCHELLE	COLLAR	COLLAR
2	12179090	2	COLLARE	COLLIER	SCHELLE	COLLAR	COLLAR
3	4613792	1	SERBATOIO	RESERVOIR	BEHAELTER	TANK	DEPOSITO
4	19053182	2	TUBO	TUBE/TUYAU	ROHR	PIPE/TUBE	TUBO
5	4617260	1	SUPPORTO	SUPPORT	LAGER	SUPPORT	SOPORTE
6	10389901	1	VITE	VIS	SCHRAUBE	SCREW	TORNILLO
7	16043821	2	VITE	VIS	SCHRAUBE	SCREW	TORNILLO
8	4023904	4	SCODELLINO	CUVETTE	TELLERSCHEIBE	CUP	PLATILLO
9	4023905	4	TASSELLO	TAMPON	BEILAGE	PAD	TACO
10	4617262	2	DISTANZIALE	ENTRETOISE	ABSTANDSTUECK	SPACER	SEPARADOR
11	11198071	2	ROSETTA DI SICUREZZA	RONDELLE FREIN	SICHERUNGSRING	LOCKWASHER	ARANDELA DE FRENO
12	16100811	2	DADO	ECROU	MUTTER	NUT	TUERCA
13	11195471	1	ROSETTA DI SICUREZZA	RONDELLE FREIN	SICHERUNGSRING	LOCKWASHER	ARANDELA DE FRENO
14	11902017	1	TAPPO	BOUCHON	STOPFEN	PLUG	TAPON
15	14330260	2	GUARNIZIONE DI TENUTA	JOINT	DICHTUNG	GASKET	JUNTA
16	4551099	1	RACCORDO	RACCORD	STUTZEN	CONNECTION	RACOR
17	4551101	1	RACCORDO	RACCORD	STUTZEN	CONNECTION	RACOR
18	4557649	1	GUARNIZIONE	GARNITURE	DICHTUNG	GASKET	JUNTA
19	4176086	1	TERMOAVVIATORE	THERMO-START	THERMOSTARTER	STARTING AID	DISPOSITIVO THERMOSTARTER

C80.50

01 02 03

CONDOTTI ASPIRAZIONE E SCARICO

Tubulures d'admission et d'échappement
Saug- und Auspuffkrümmer

Intake and Exhaust Manifolds
Colectores de admisión y escape

10.8/2

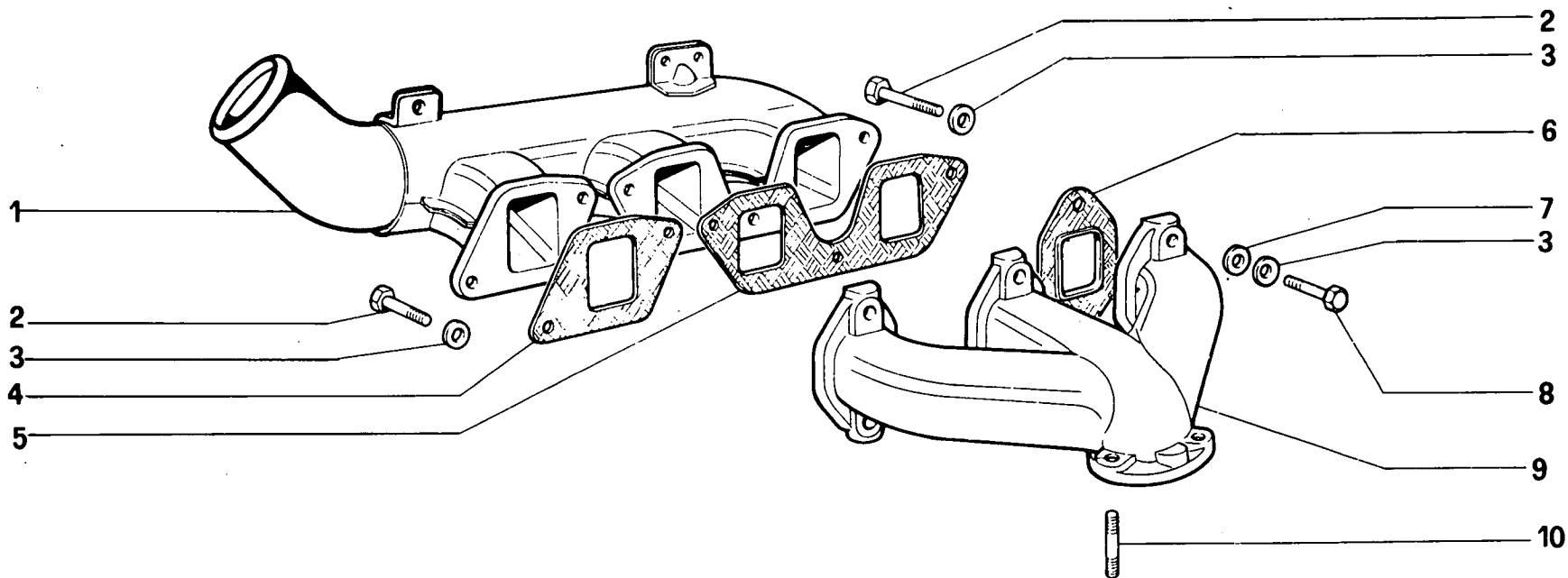

C80/50

CONDOTTI ASPIRAZIONE E SCARICO

10.08/02

(09-1981)

FIG	N. ORDINAZIONE	QTA	DENOMINAZIONE	DESIGNATION	BENENNUNG	DESCRIPTION	DENOMINACIONES
1	4602345	1	COLLETORE DI ASPIRAZIONE	COUDE ASPIRATION	ANSAUGKRUEMMER	INTAKE ELBOW	CODO ASPIRACION
2	16043421	5	VITE	VIS	SCHRAUBE	SCREW	TORNILLO
3	11198071	11	ROSETTA DI SICUREZZA	RONDELLE FREIN	SICHERUNGSRING	LOCKWASHER	ARANDELA DE FRENO
4	4602162	1	GUARNIZIONE	GARNITURE	DICHTUNG	GASKET	JUNTA
5	4601827	1	GUARNIZIONE	GARNITURE	DICHTUNG	GASKET	JUNTA
6	4601981	3	GUARNIZIONE	GARNITURE	DICHTUNG	GASKET	JUNTA
7	10519601	6	ROSETTA DI SICUREZZA	RONDELLE FREIN	SICHERUNGSRING	LOCKWASHER	ARANDELA DE FRENO
8	16043821	8	VITE	VIS	SCHRAUBE	SCREW	TORNILLO
9	4607842	1	COLLETORE DI SCARICO	COUDE D'ECHAPPEMT	AUSLASSKRUEMMER	EXHAUST ELBOW	CODO ESCAPE
10	13543710	3	PRIGIONIERO	GOUJON	STIFTSCHRAUBE	STUD	ESPARRAGO

CEC 50

01 02 03

TUBAZIONE DI SCARICO

Canalisation d'échappement
Auspuffleitung

Exhaust Pipe
Tubería de escape

10.8/3

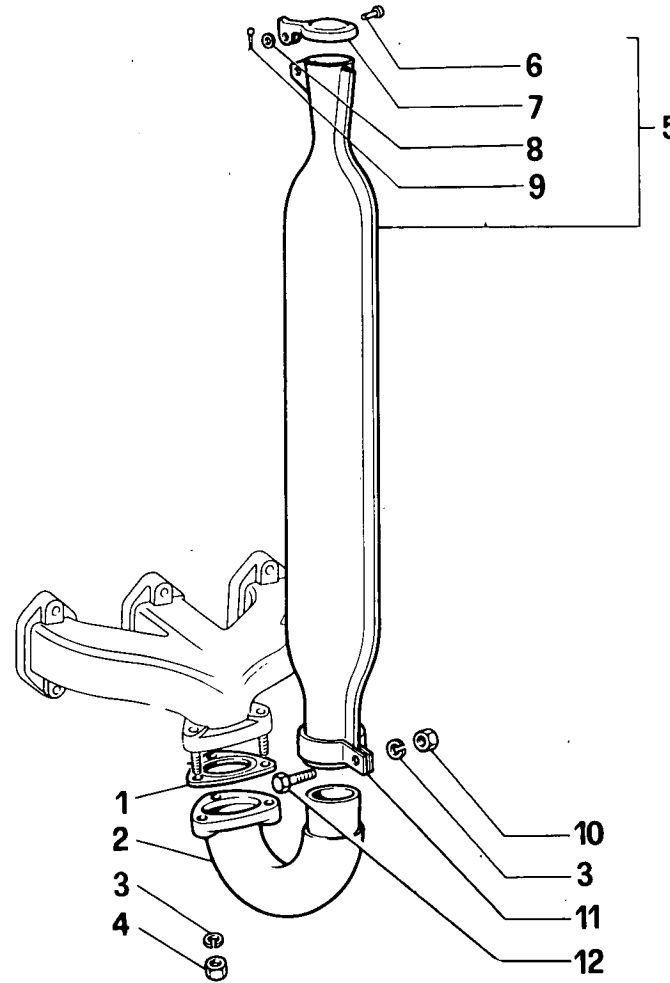

C80/50

TUBAZIONE DI SCARICO

10.08/03

(09-1981)

FIG	N. ORDINAZIONE	QTA	DENOMINAZIONE	DESIGNATION	BENENNUNG	DESCRIPTION	DENOMINACIONES
1	4610742	1	GUARNIZIONE	GARNITURE	DICHTUNG	GASKET	JUNTA
2	5118066	1	GOMITO	COUDE	KNIESTUECK	ELBOW	CODO
3	10516671	4	ROSETTA DI SICUREZZA	RONDELLE FREIN	SICHERUNGSRING	LOCKWASHER	ARANDELA DE FRENO
4	747144	3	DADO	ECROU	MUTTER	NUT	TUERCA
5	5117618	1	SILENZIATORE DI SCARICO COMPLETO	SILENCIEUX D'ECHAPPEMENT	ABGASSCHALLDAEMPF	AXHAUST SILENCER	SILENCIADOR DE ESCAPE
6	4990945	1	PERNO	AXE	BOLZEN	PIN	EJE
7	5117619	1	COPERCHIO	COUVERCLE	DECKEL	COVER	TAPA
8	10519601	1	ROSETTA DI SICUREZZA	RONDELLE FREIN	SICHERUNGSRING	LOCKWASHER	ARANDELA DE FRENO
9	10734201	1	COPIGLIA	GOUPILLE	SPLINT	SPLIT PIN	PASADOR ABIERTO
10	16100840	1	DADO	ECROU	MUTTER	NUT	TUERCA
11	5117610	1	COLLARE	COLLIER	SCHELLE	COLLAR	COLLAR
12	16043621	1	VITE	VIS	SCHRAUBE	SCREW	TORNILLO

Canalisation d'échappement
Auspuffleitung

Exhaust Pipe
Tuberla de escape

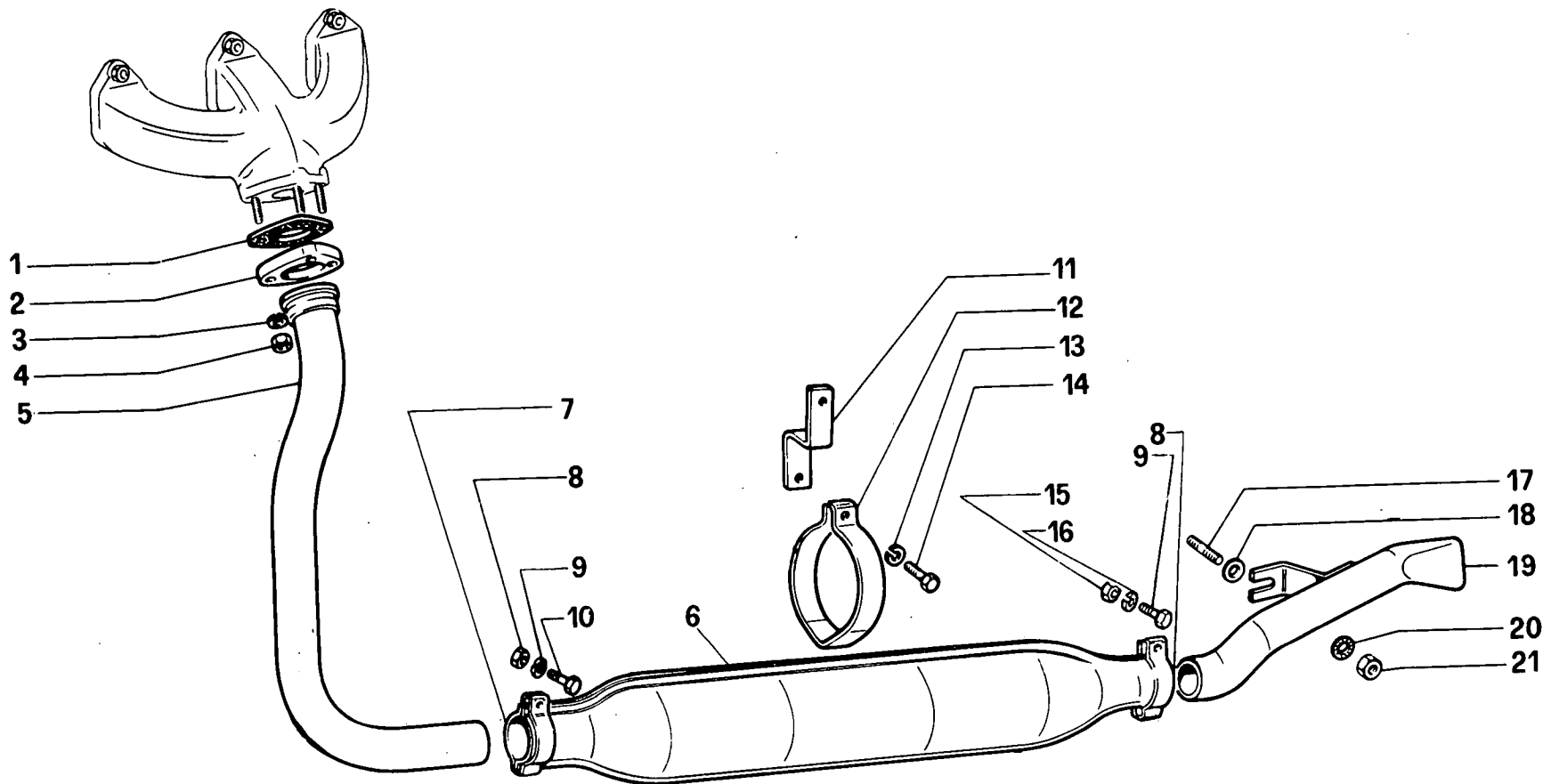

C80/50

TUBAZIONE DI SCARICO

10.08/04

(09-1981)

FIG	N. ORDINAZIONE	QTA	DENOMINAZIONE	DESIGNATION	BENENNUNG	DESCRIPTION	DENOMINACIONES
1	4610742	1	GUARNIZIONE	GARNITURE	DICHTUNG	GASKET	JUNTA
2	5117612	1	FLANGIA	BRIDE	FLANSCH	FLANGE	BRIDA
3	10516671	2	ROSETTA DI SICUREZZA	RONDELLE FREIN	SICHERUNGSRING	LOCKWASHER	ARANDELA DE FRENO
4	747144	3	DADO	ECROU	MUTTER	NUT	TUERCA
5	5117608	1	TUBO ANT.	TUBE/TUYAU	ROHR	PIPE/TUBE	TUBO
6	5117607	1	SILENZIATORE DI SCARICO	SILENCIEUX D'ECHAPPEMENT	ABGASSCHALLDAEMPF	AXHAUST SILENCER	SILENCIADOR DE ESCAPE
7	5117610	1	COLLARE	COLLIER	SCHELLE	COLLAR	COLLAR
8	16100840	2	DADO	ECROU	MUTTER	NUT	TUERCA
9	10516671	2	ROSETTA DI SICUREZZA	RONDELLE FREIN	SICHERUNGSRING	LOCKWASHER	ARANDELA DE FRENO
10	16043821	1	VITE	VIS	SCHRAUBE	SCREW	TORNILLO
11	5118068	1	STAFFA	ETRIER	HALTER	BRACKET	SOPORTE
12	5117611	1	COLLARE	COLLIER	SCHELLE	COLLAR	COLLAR
13	10516871	1	ROSETTA DI SICUREZZA	RONDELLE FREIN	SICHERUNGSRING	LOCKWASHER	ARANDELA DE FRENO
14	15970921	1	VITE	VIS	SCHRAUBE	SCREW	TORNILLO
15	44900813	1	COLLARE POST.	COLLIER	SCHELLE	COLLAR	COLLAR
16	16043621	1	VITE	VIS	SCHRAUBE	SCREW	TORNILLO
17	11796320	1	PRIGIONIERO	GOUJON	STIFTSCHRAUBE	STUD	ESPARRAGO
18	10520001	1	ROSETTA PIANA	RONDELLE	SCHEIBE	WASHER	ARANDELA
19	5117609	1	TERMINALE	BORNE	LABELSCHUH	TERMINAL	TERMINAL
20	12598879	1	ROSETTA DI SICUREZZA	RONDELLE FREIN	SICHERUNGSRING	LOCKWASHER	ARANDELA DE FRENO
21	12163911	1	DADO	ECROU	MUTTER	NUT	TUERCA

FRIZIONE

Embrayage
Kupplung

Clutch
Embrague

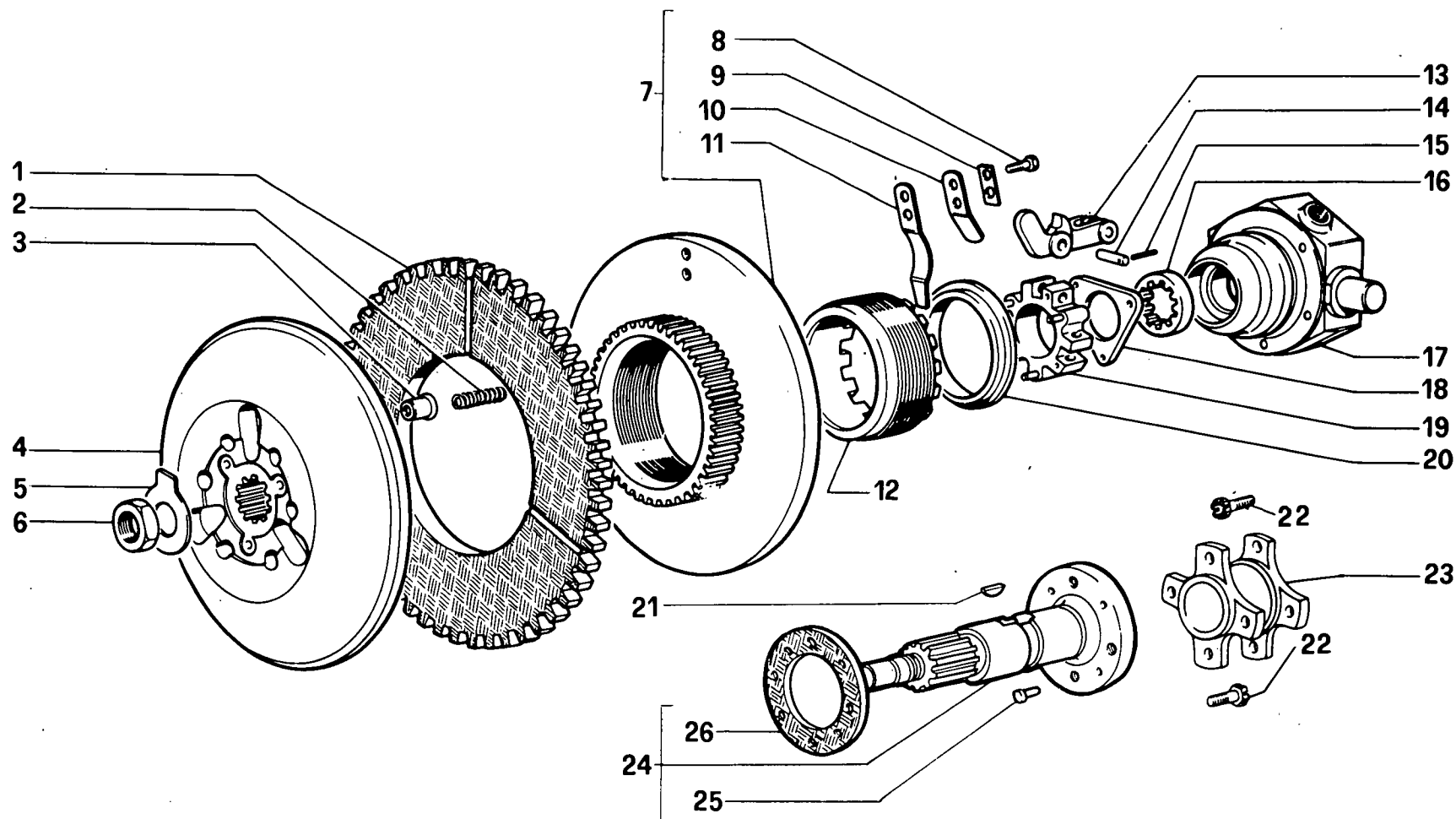

C80/50

FRIZIONE

20.05/01

(09-1981)

FIG	N. ORDINAZIONE	QTA	DENOMINAZIONE	DESIGNATION	BENENNUNG	DESCRIPTION	DENOMINACIONES
1	599728	1	FRIZIONE COMPLETA	EMBAYAGE	KUPPLUNG	CLUTCH	EMBRAGUE
	588433	2	DISCO CONDUTT. FRIZIONE	DISQUE ENTRAINEUR EMBRY	KUPPLUNGSSCHEIBE	CLUTCH DRIVING PLATE	DISCO DE APRIETE
2	596516	6	MOLLA	RESSORT	FEDER	SPRING	RESORTE
3	565617	6	SCODELLINO	CUVETTE	TELLERSCHEIBE	CUP	PLATILLO
4	596513	1	ANELLO SPINGIDISCO	PLATEAU DE PRESSION	DRUCKPLATTE	PRESSURE PLATE	PLATO DE EMPUJE
5	567633	1	PIASTRINA DI SICUREZZA	PLAQUETTE FREIN	SICHERUNGSBLECH	LOCKPLATE	PLACA DE FRENO
6	582321	1	DADO	ECROU	MUTTER	NUT	TUERCA
7	599730	1	ANELLO SPINGIDISCO	PLATEAU DE PRESSION	DRUCKPLATTE	PRESSURE PLATE	PLATO DE EMPUJE
8	10979421	2	VITE	VIS	SCHRAUBE	SCREW	TORNILLO
9	569438	1	PIASTRINA DI SICUREZZA	PLAQUETTE FREIN	SICHERUNGSBLECH	LOCKPLATE	PLACA DE FRENO
10	569437	1	RINFORZO MOLLA	RENFORT	VERSTAERKUNG	REINFORGEMENT	REFUERZO
11	569436	3	MOLLA	RESSORT	FEDER	SPRING	RESORTE
12	599731	1	GHIERA REGISTRO	VIROLE	GEWINDERING	PLUG	VIROLA
13	595864	3	LEVA DI INNESTO FRIZIONE	LEVIER D'EMBAYAGE	EINRUECKHEBEL	ENGAGING LEVER	PALANCA CONEXION
14	565620	3	PERNO	AXE	BOLZEN	PIN	EJE
15	14161970	3	SPINA	GOUPILLE	STIFT	PIN	PASADOR
16	572000	1	MANICOTTO	MANCHON	MUFFE	SLEEVE	MANGUITO
17	4984282	1	MANICOTTO INNESTO	MANCHON D'EMBAYAGE	EINRUECKMUFFE	ENGAGING SLEEVE	MANGUITO CONEXION
18	572001	1	PIASTRA DI REAZIONE	PLAQUE	PLATTE	PLATE	PLACA
19	571999	1	SUPPORTO LEVE	SUPPORT	LAGER	SUPPORT	SOPORTE
20	570226	1	ANELLO GHIERA	BAGUE	RING	RING	ANILLO
21	10205910	1	LINGUETTA	LINGUET	SCHEIBENFEDER	KEY	CHAVETA
22	570933	8	VITE	VIS	SCHRAUBE	SCREW	TORNILLO
23	580197	1	GIUNTO FRIZIONE	ACCOUPEMENT	KUPPLUNG	COUPLING	ARRASTRE
24	4984280	1	ALBERO FRIZIONE COMPL.	ARBRE D'EMBAYAGE	KUPPLUNGSWELLE	CLUTCH SHAFT	EJE EMBRAGUE
25	13868350	4	RIBATTINO	RIVET	NIET	RIVET	REMACHE
26	571707	1	GUARNIZIONE	GARNITURE	DICHTUNG	GASKET	JUNTA

CEB 50

01 02 03

SCATOLA CAMBIO

Carter de boîte
Getriebegehäuse

Transmission case
Caja engranaje

30.1/1

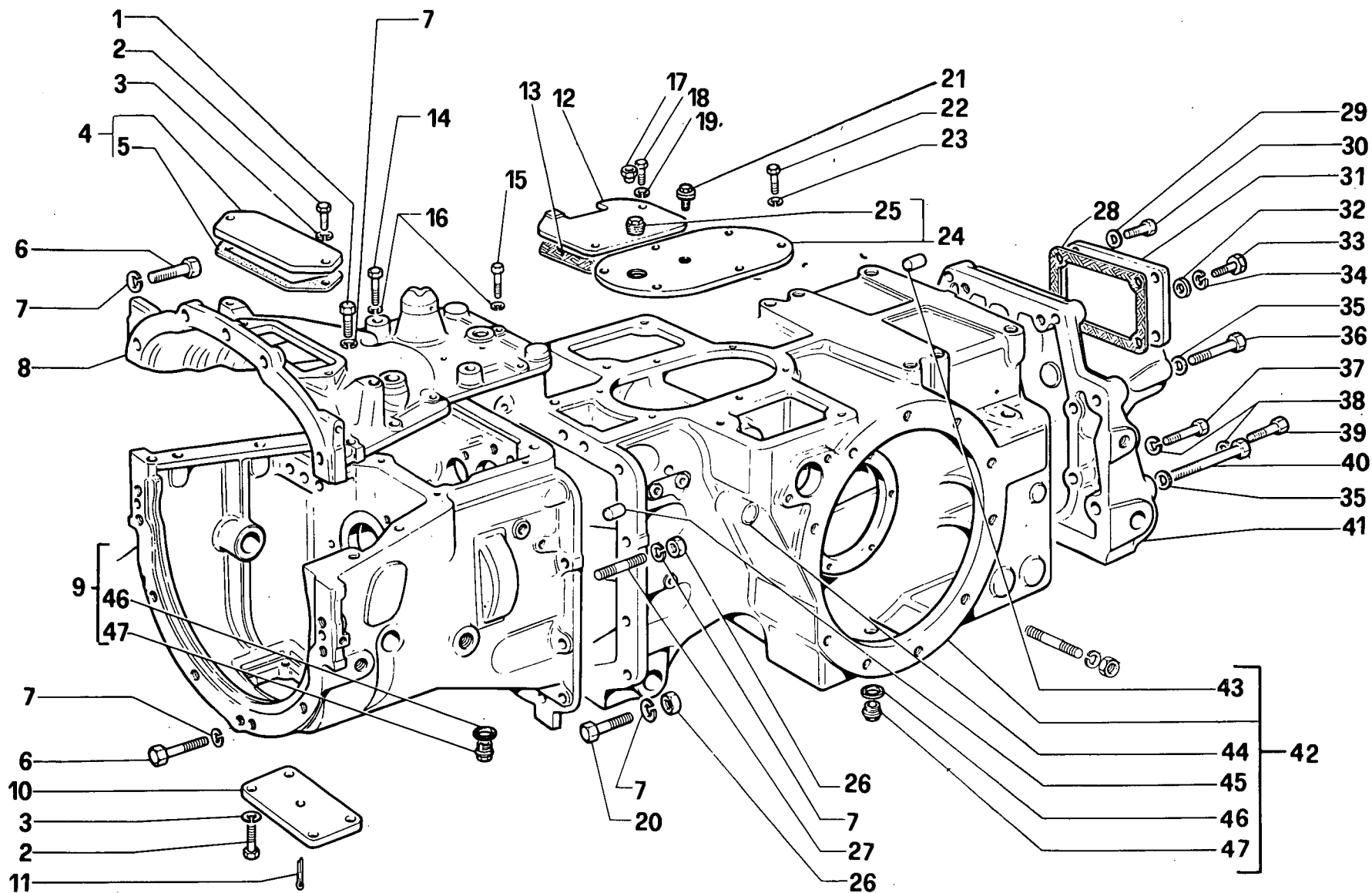

C80/50

SCATOLA CAMBIO

30.01/01

(09-1981)

FIG	N. ORDINAZIONE	QTA	DENOMINAZIONE	DESIGNATION	BENENNUNG	DESCRIPTION	DENOMINACIONES
1	11363021	4	VITE	VIS	SCHRAUBE	SCREW	TORNILLO
2	15970521	6	VITE	VIS	SCHRAUBE	SCREW	TORNILLO
3	10516871	6	ROSETTA DI SICUREZZA	RONDELLE FREIN	SICHERUNGSRING	LOCKWASHER	ARANDELA DE FRENO
4	568478	1	COPERCHIO	COUVERCLE	DECKEL	COVER	TAPA
5	569625	1	GUARNIZIONE	GARNITURE	DICHTUNG	GASKET	JUNTA
6	15540721	13	VITE	VIS	SCHRAUBE	SCREW	TORNILLO
7	10517071	17	ROSETTA DI SICUREZZA	RONDELLE FREIN	SICHERUNGSRING	LOCKWASHER	ARANDELA DE FRENO
8	5011812	1	COPERCHIO	COUVERCLE	DECKEL	COVER	TAPA
9	5102663	1	SCATOLA FRIZIONF CAMBIO	CARTER D'EMBRAYAGE	KUPPLUNGSGEHAEUSE	CLUTCH HOUSING	CAJA EMBRAGUE
10	5103242	1	COPERCHIO INF.	COUVERCLE	DECKEL	COVER	TAPA
11	10798101	1	COPIGLIA	GOUPILLE	SPLINT	SPLIT PIN	PASADOR ABIERTO
12	4950098	1	COPERCHIO SCATOLA CAMBIO	COUVERCLE CART B V	GETRIEBEGEH. DECKEL	TRANSMISSION COVER	TAPA ENGRANAJE
13	4978258	1	GUARNIZIONE	GARNITURE	DICHTUNG	GASKET	JUNTA
14	16043921	1	VITE	VIS	SCHRAUBE	SCREW	TORNILLO
15	16043321	5	VITE	VIS	SCHRAUBE	SCREW	TORNILLO
16	10516671	6	ROSETTA DI SICUREZZA	RONDELLE FREIN	SICHERUNGSRING	LOCKWASHER	ARANDELA DE FRENO
17	582232	4	ECCENTRICO	EXCENTRIQUE	EXZENTER	CAM	EXCENTRICA
18	15970721	4	VITE	VIS	SCHRAUBE	SCREW	TORNILLO
19	11198371	8	ROSETTA DI SICUREZZA	RONDELLE FREIN	SICHERUNGSRING	LOCKWASHER	ARANDELA DE FRENO
20	11227721	7	VITE	VIS	SCHRAUBE	SCREW	TORNILLO
21	13413290	1	VITE DI SFIATO	VIS D'EVENT	ENTLUEFTUNGSSCHRAU- BE	VENT SCREW	TORNILLO DE RESPIRACION
22	16043221	6	VITE	VIS	SCHRAUBE	SCREW	TORNILLO
23	10516671	6	ROSETTA DI SICUREZZA	RONDELLE FREIN	SICHERUNGSRING	LOCKWASHER	ARANDELA DE FRENO
24	4952678	1	COPERCHIO SUP.	COUVERCLE	DECKEL	COVER	TAPA
25	14323311	1	TAPPO	BOUCHON	STOPFEN	PLUG	TAPON
26	10790311	11	DADO	ECROU	MUTTER	NUT	TUERCA
27	11794720	4	PRIGIONIERO	GOUJON	STIFTSCHRAUBE	STUD	ESPARRAGO
28	4976069	1	GUARNIZIONE	GARNITURE	DICHTUNG	GASKET	JUNTA
29	10517171	4	ROSETTA DI SICUREZZA	RONDELLE FREIN	SICHERUNGSRING	LOCKWASHER	ARANDELA DE FRENO
30	11408321	4	VITE	VIS	SCHRAUBE	SCREW	TORNILLO
31	571965	1	COPERCHIO P.T.O.	COUVERCLE	DECKEL	COVER	TAPA
32	11200171	4	ROSETTA DI SICUREZZA	RONDELLE FREIN	SICHERUNGSRING	LOCKWASHER	ARANDELA DE FRENO

-800-

Carter de boîte
Getriebegehäuse

Transmission case
Caja engranaje

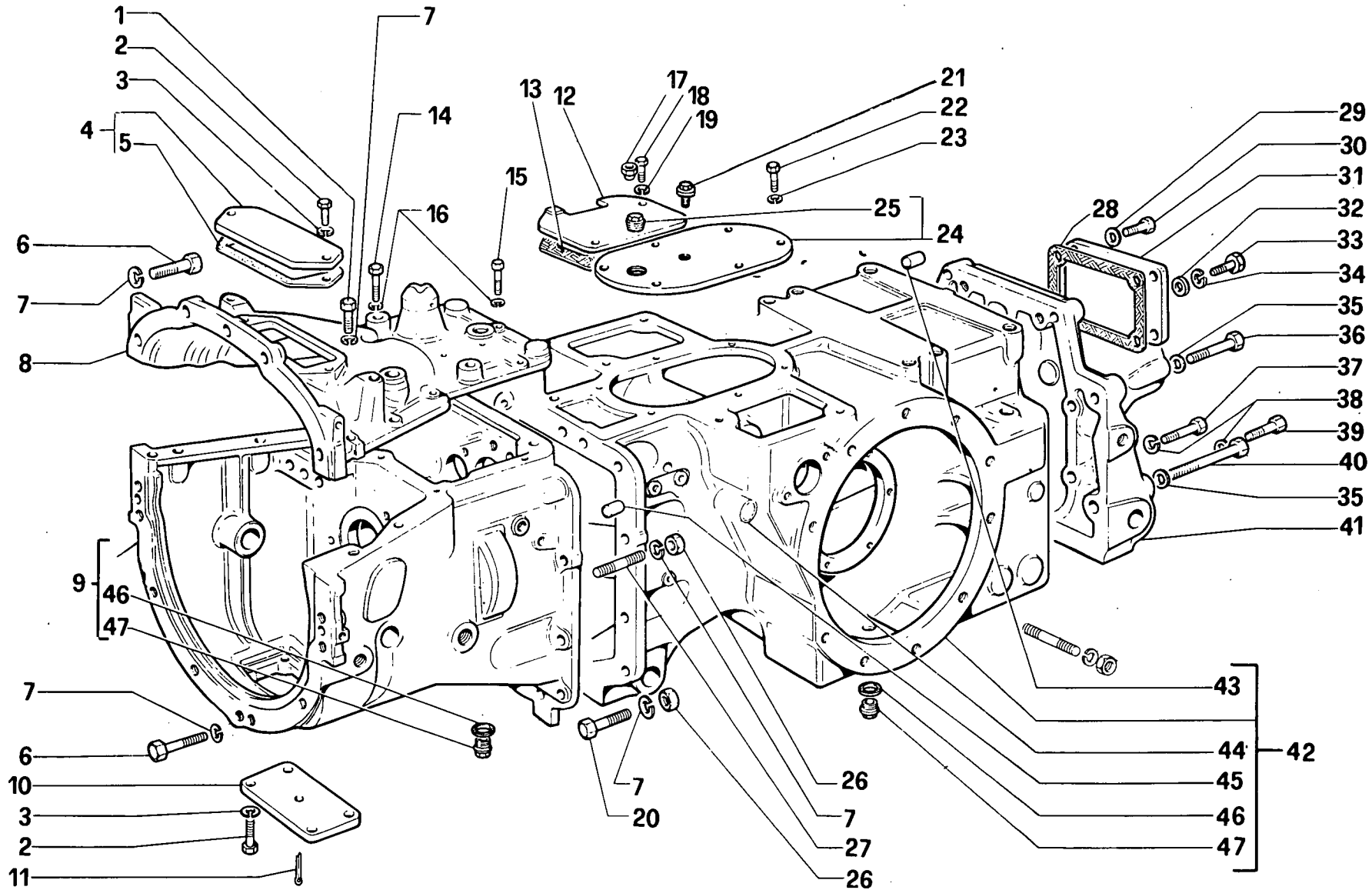

C80/50

SCATOLA CAMBIO

30.01/01

(09-1981)

FIG	N. ORDINAZIONE	QTA	DENOMINAZIONE	DESIGNATION	BENENNUNG	DESCRIPTION	DENOMINACIONES
33	11359921	4	VITE -800-	VIS	SCHRAUBE	SCREW	TORNILLO
34	10520101	4	ROSETTA DI SICUREZZA -800-	RONDELLE FREIN	SICHERUNGSRING	LOCKWASHER	ARANDELA DE FRENO
35	11200271	4	ROSETTA DI SICUREZZA	RONDELLE FREIN	SICHERUNGSRING	LOCKWASHER	ARANDELA DE FRENO
36	15840521	2	VITE	VIS	SCHRAUBE	SCREW	TORNILLO
37	11307721	6	VITE	VIS	SCHRAUBE	SCREW	TORNILLO
38	11198671	8	ROSETTA DI SICUREZZA	RONDELLE FREIN	SICHERUNGSRING	LOCKWASHER	ARANDELA DE FRENO
39	11201121	2	VITE	VIS	SCHRAUBE	SCREW	TORNILLO
40	11369621	2	VITE	VIS	SCHRAUBE	SCREW	TORNILLO
41	5103051	1	COPERCHIO POST.	COUVERCLE	DECKEL	COVER	TAPA
42	5107399	1	SCATOLA CAMBIO (01-02)	CARTER DE BOITE V	GETRIEBEGEHAUSE	TRANSMISSION CASE	CAJA ENGRANAJE
42	5107402	1	SCATOLA CAMBIO -03-	CARTER DE BOITE V	GETRIEBEGEHAUSE	TRANSMISSION CASE	CAJA ENGRANAJE
43	10839710	2	SPINA	GOUPILLE	STIFT	PIN	PASADOR
44	4958508	2	BOCCOLA	DOUILLE	BUECHSE	BUSH	CASQUILLO
45	10839910	2	SPINA	GOUPILLÉ	STIFT	PIN	PASADOR

Carter de boîte
Getriebegehäuse

Transmission case
Caja engranaje

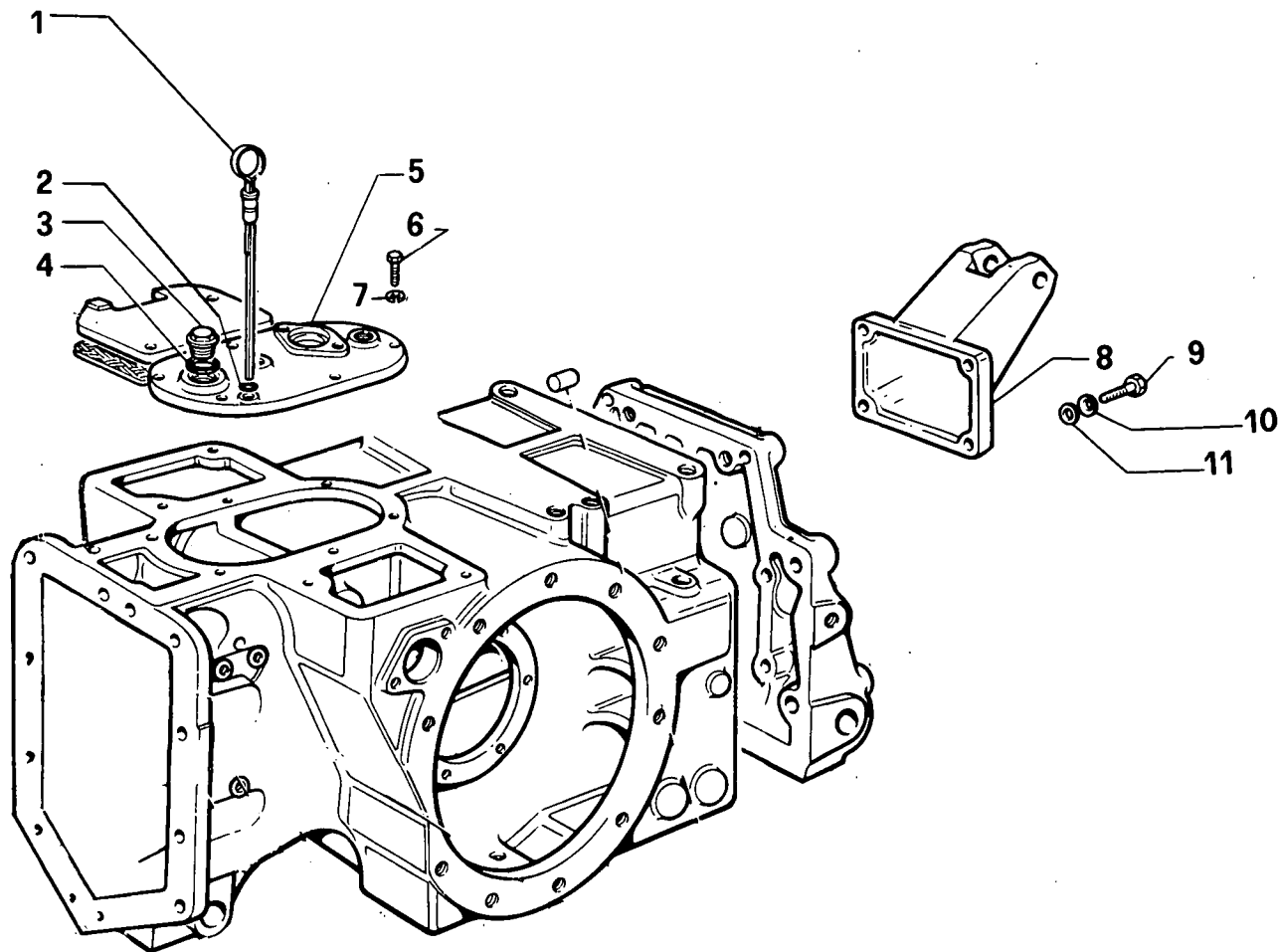

C80/50

SCATOLA CAMBIO - 820

30.01/02

(09-1981)

FIG	N. ORDINAZIONE	QTA	DENOMINAZIONE	DESIGNATION	BENENNUNG	DESCRIPTION	DENOMINACIONES
1	4956516	1	ASTA LIVELLO OLIO	JAUGE D'HUILE	OELMESSSTAB	OIL DIPSTICK	VARIL. NIVEL ACEITE
2	14452780	1	GUARNIZIONE	GARNITURE	DICHTUNG	GASKET	JUNTA
3	10305171	1	TAPPO	BOUCHON	STOPFEN	PLUG	TAPON
4	10263460	1	GUARNIZIONE DI TENUTA	JOINT	DICHTUNG	GASKET	JUNTA
5	4953668	1	COPERCHIO	COUVERCLE	DECKEL	COVER	TAPA
6	10516671	6	ROSETTA DI SICUREZZA	RONDELLE FREIN	SICHERUNGSRING	LOCKWASHER	ARANDELA DE FRENO
7	16043621	6	VITE	VIS	SCHRAUBE	SCREW	TORNILLO
8	4953768	1	SUPPORTO	SUPPORT	LAGER	SUPPORT	SOPORTE
9	11394321	4	VITE	VIS	SCHRAUBE	SCREW	TORNILLO
10	11200171	4	ROSETTA DI SICUREZZA	RONDELLE FREIN	SICHERUNGSRING	LOCKWASHER	ARANDELA DE FRENO
11	10520101	4	ROSETTA DI SICUREZZA	RONDELLE FREIN	SICHERUNGSRING	LOCKWASHER	ARANDELA DE FRENO

Engrenages de boîte de vitesses
Zahnräder und Wellen des Wechselgetriebes

Transmission Gears
Engranajes del cambio

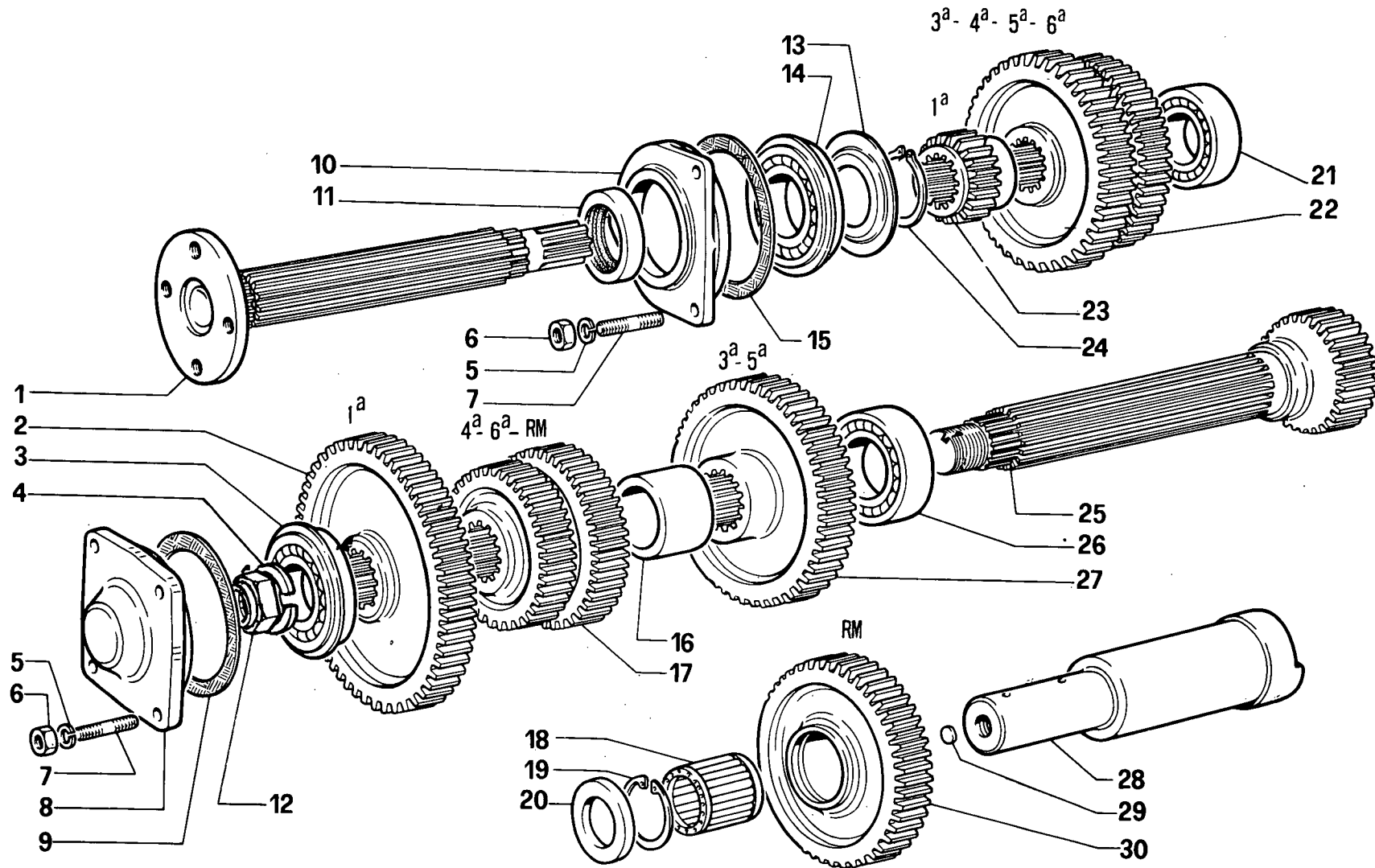

C80/50

CAMBIO VELOCITA°

30.02/01

(09-1981)

FIG	N. ORDINAZIONE	QTA	DENOMINAZIONE	DESIGNATION	BENENNUNG	DESCRIPTION	DENOMINACIONES
1	583545	1	ALBERO PRIMARIO	ARBRE PRIMAIRE	HAUPTWELLE	MAIN-SHAFT	ARBOL PRIMARIO
2	561991	1	INGRANAGGIO CONDOTTO I VELOCITA°	PIGNON CONDUIT	ANGETRIEBENES ZAHNRAD	DRIVEN GEAR	PINON CONDUCIDO
3	28995870	1	CUSCINETTO	ROULEMENT	LAGER	BEARING	RODAMIENTO
4	4960041	1	ANELLO SPALLAMENTO	BAGUE A EPAULEMENT	SCHULTERRING	RING	ANILLO CON REBORDE
5	10516671	7	ROSETTA DI SICUREZZA	RONDELLE FREIN	SICHERUNGSRING	LOCKWASHER	ARANDELA DE FRENO
6	14048211	7	DADO AUTOBLOCCANTE	ECROU AUTO-FREINE	SELBSTSICH. MUTTER	SELF-LOCKING NUT	TUERCA AUTOAFIANZ.
7	13517010	7	PRIGIONIERO	GOUJON	STIFTSCHRAUBE	STUD	ESPARRAGO
8	5101590	1	COPERCHIO	COUVERCLE	DECKEL	COVER	TAPA
9	14461280	1	ANELLO OR	BAGUE TORIQUE	O-RING	O-SEAL	ANILLO O.
10	4996277	1	COPERCHIO	COUVERCLE	DECKEL	COVER	TAPA
11	5107816	1	ANELLO DI TENUTA	JOINT D°ETANCHEITE	DICHTRING	SEAL	JUNTA HERMETICA
12	14045271	1	DADO	ECROU	MUTTER	NUT	TUERCA
13	570849	1	DISCO PARAOLIO	DISQUE	SCHEIBE	PLATE	DISCO
14	28996320	1	CUSCINETTO	ROULEMENT	LAGER	BEARING	RODAMIENTO
15	14461180	1	ANELLO OR	BAGUE TORIQUE	O-RING	O-SEAL	ANILLO O.
16	563466	1	DISTANZIALE	ENTRETOISE	ABSTANDSTUECK	SPACER	SEPARADOR
17	565544	1	INGRANAGGIO CONDOTTO	PIGNON CONDUIT	ANGETRIEBENES ZAHNRAD	DRIVEN GEAR	PINON CONDUCIDO
18	28041620	1	GABBIA A RULLI	CAGE A ROULEAUX	ROLLENKAEFIG	ROLLER CAGE	PORTARRODILLOS
19	561719	1	ANELLO DI SICUREZZA	ARRETOIR	SICHERUNGSRING	LOCKRING	ANILLO DE FRENO
20	563051	1	ROSETTA PIANA	RONDELLE	SCHEIBE	WASHER	ARANDELA
21	20705250	1	CUSCINETTO	ROULEMENT	LAGER	BEARING	RODAMIENTO
22	4951439	1	INGRANAGGIO CONDUTTORE	PIGNON CONDUCTEUR	TREIBENDES ZAHNRAD	DRIVING GEAR	PINON CONDUCTOR
23	583546	1	INGRANAGGIO CONDUTTORE I VEL III - IV - VI VEL.	PIGNON CONDUCTEUR	TREIBENDES ZAHNRAD	DRIVING GEAR	PINON CONDUCTOR
24	11068876	1	ANELLO DI SICUREZZA	ARRETOIR	SICHERUNGSRING	LOCKRING	ANILLO DE FRENO
25	4959911	1	ALBERO SECONDARIO	ARBRE SECONDAIRE	VORGELEGEWELLE	COUNTERSHAFT	ARBOL SECONDARIO
26	20045200	1	CUSCINETTO	ROULEMENT	LAGER	BEARING	RODAMIENTO
27	4951440	1	INGRANAGGIO CONDOTTO III - V - VEL.	PIGNON CONDUIT	ANGETRIEBENES ZAHNRAD	DRIVEN GEAR	PINON CONDUCIDO
28	565541	1	ALBERO RETROMARCIA	ARBRE DE MARCHE AR.	RUECKLAUFWELLE	RETURN SHAFT	EJE MARCHA ATRAS
29	10158300	1	TAPPO	BOUCHON	STOPFEN	PLUG	TAPON

CAMBIO DI VELOCITÀ

Engrenages de boîte de vitesses
Zahnräder und Wellen des Wechselgetriebes

Transmission Gears
Engranajes del cambio

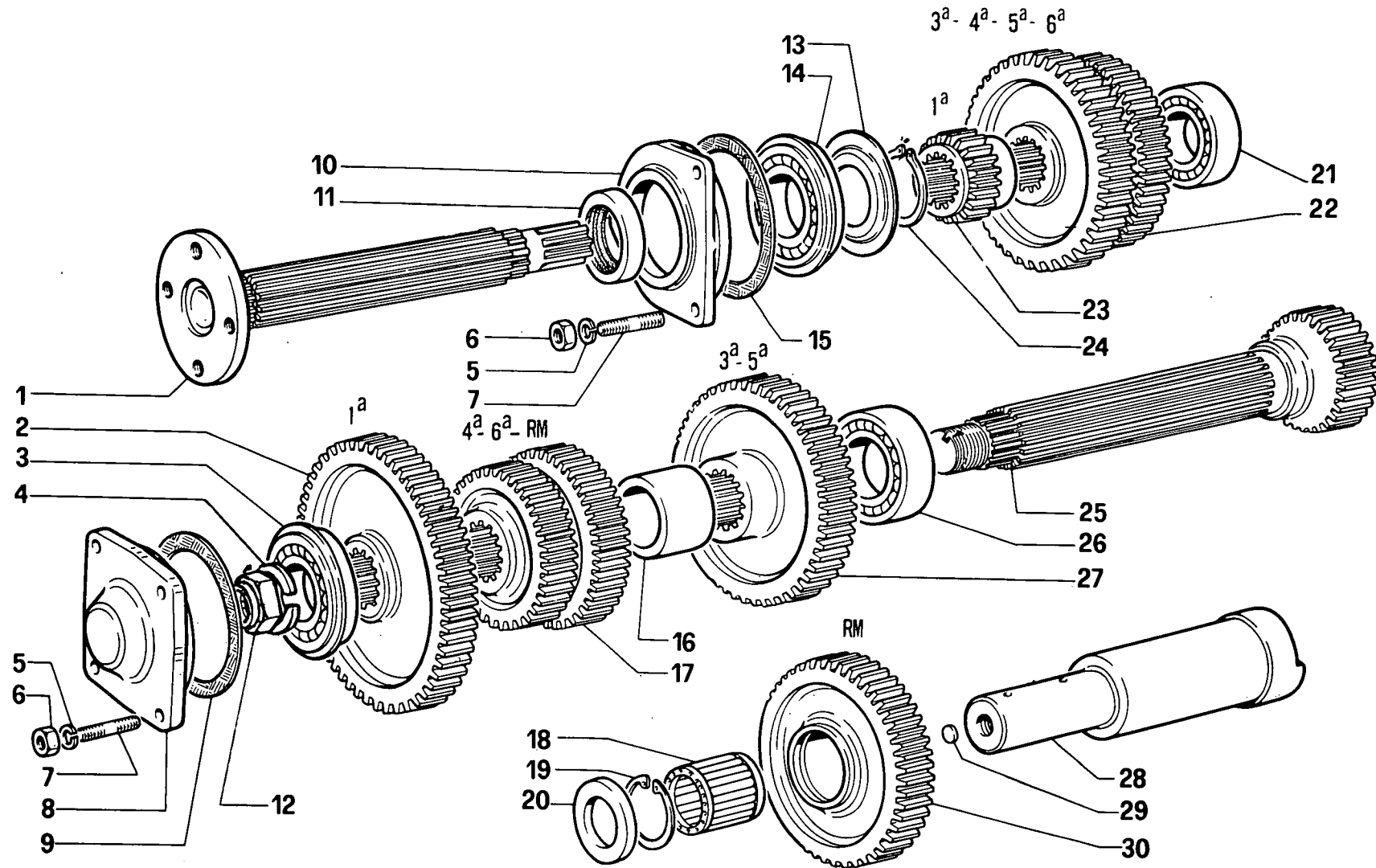

C80/50

CAMBIO VELOCITA°

30.02/01

(09-1981)

FIG	N. ORDINAZIONE	QTA	DENOMINAZIONE	DESIGNATION	BENENNUNG	DESCRIPTION	DENOMINACIONES
30	565545	1	INGRANAGGIO RETROMARCIA	PIGNON DE MARCHE AR.	RUECKLAUFRAD	REVERSE GEAR	RUEDA MARCHA ATRAS.

RIDUTTORE CAMBIO

Engrenages de réducteur de boîte de vitesses
Räder und Wellen des Zusatzgetriebes

Reduction Gears
Engranajes del reductor del cambio

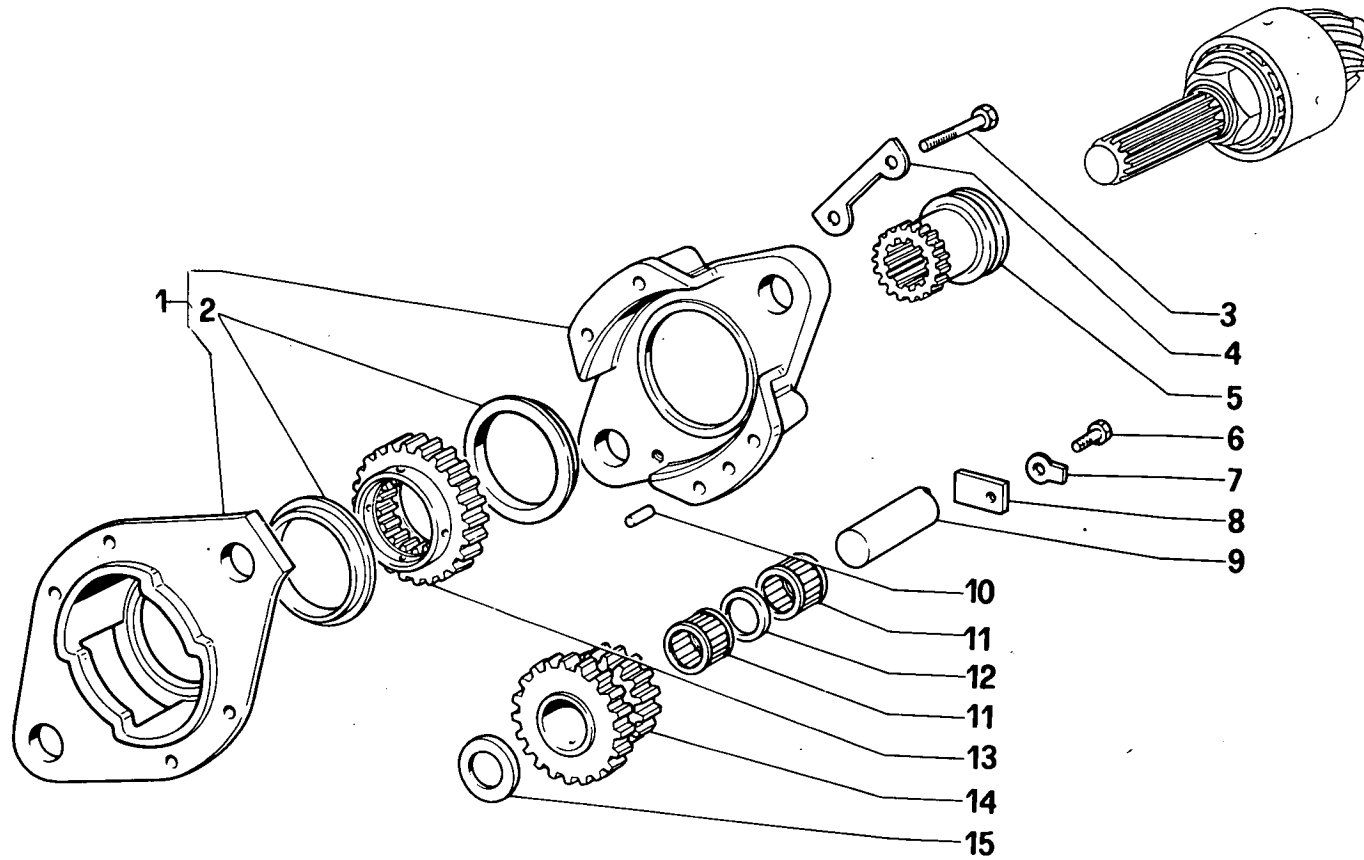

C80/50

RIDUTTORE CAMBIO

30.04/01

(09-1981)

FIG	N. ORDINAZIONE	QTA	DENOMINAZIONE	DESIGNATION	BENENNUNG	DESCRIPTION	DENOMINACIONES
1	584435	1	SUPPORTO COMPLETO	SUPPORT	LAGER	SUPPORT	SOPORTE
2	569171	2	BOCCOLA	DOUILLE	BUECHSE	BUSH	CASQUILLO
3	11244421	4	VITE	VIS	SCHRAUBE	SCREW	TORNILLO
4	565538	2	PIASTRINA DI SICUREZZA	PLAQUETTE FREIN	SICHERUNGSBLECH	LOCKPLATE	PLACA DE FRENO
5	565533	1	MANICOTTO INNESTO	MANCHON D'EMBAYAGE	EINRUECKMUFFE	ENGAGING SLEEVE	MANGUITO CONEXION
6	16043221	2	VITE	VIS	SCHRAUBE	SCREW	TORNILLO
7	10053510	2	ROSETTA DI SICUREZZA	RONDELLE FREIN	SICHERUNGSRING	LOCKWASHER	ARANDELA DE FRENO
8	5103320	2	PIASTRINA DI SICUREZZA	PLAQUETTE FREIN	SICHERUNGSBLECH	LOCKPLATE	PLACA DE FRENO
9	565531	2	PERNO INGRANAGGI	AXE	BOLZEN	PIN	EJE
10	10839810	1	SPINA	GOUPILLE	STIFT	PIN	PASADOR
11	28041610	4	GABBIA A RULLI	CAGE A ROULEAUX	ROLLENKAEFIG	ROLLER CAGE	PORTARRODILLOS
12	565537	2	DISTANZIALE	ENTRETOISE	ABSTANDSTUECK	SPACER	SEPARADOR
13	568426	1	INGRANAGGIO CONDOTTO	PIGNON CONDUIT	ANGETRIEBENES ZAHNRAD	DRIVEN GEAR	PINON CONDUcido
14	1909071	1	INGRANAGGIO DI RINVIO	PIGNON DE RENVOI	ZWISCHENZAHNRAD	IDLE GEAR	PINON DE REENVIO
15	565540	4	ANELLO RASAMENTO	ANNEAU COMPENSATEUR	AUSGLEICHRING	SHIM	ARO COMPENSACION

CEB.50

01 02 03

DIFFERENZIALE POSTERIORE

Différentiel AR.
Ausgleichgetriebehinten

Rear differential
Diferencial posterior

30.5/1

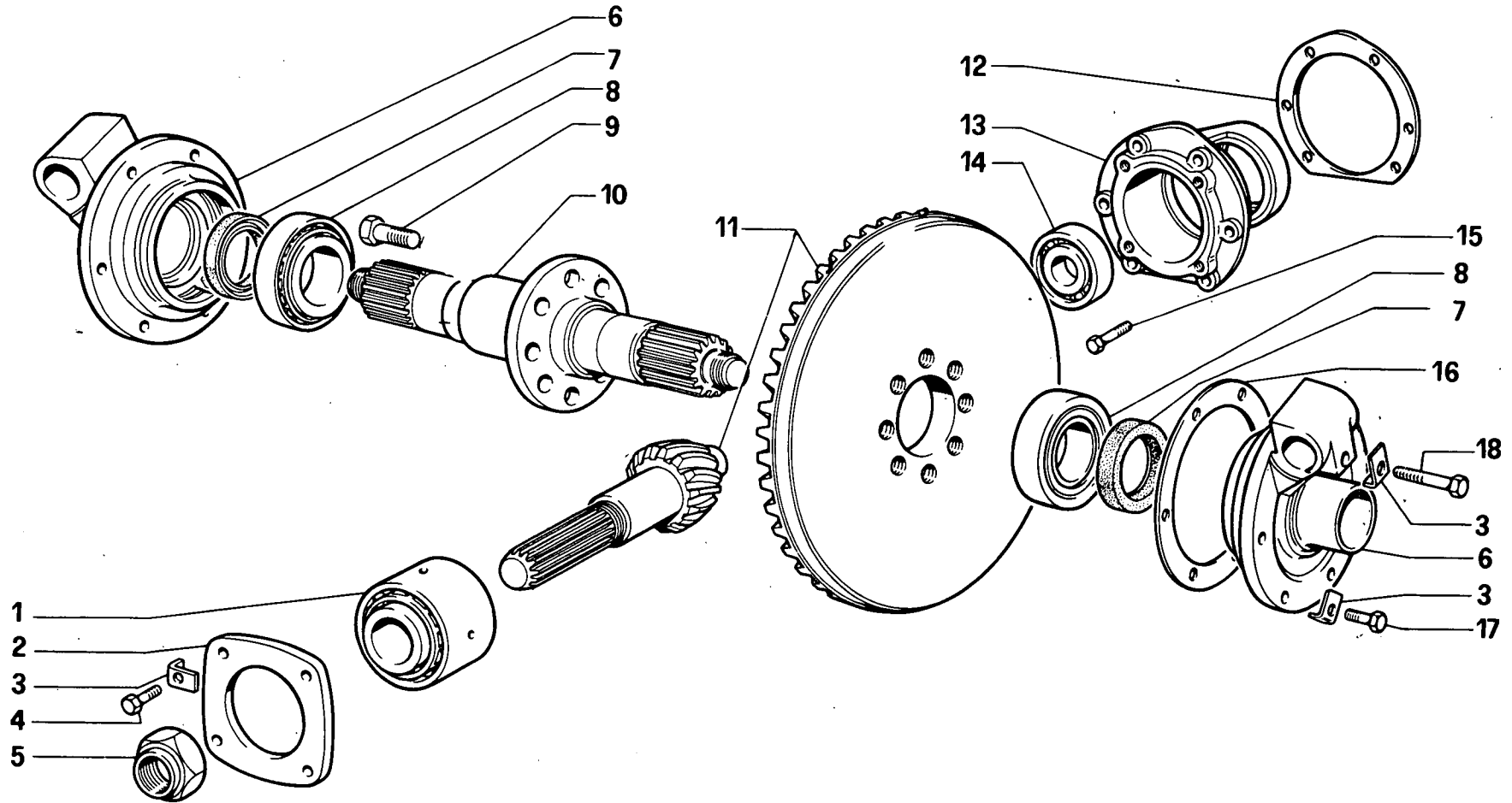

C80/50

DIFFERENZIALE POSTERIORE

30.05/01

(09-1981)

FIG	N. ORDINAZIONE	QTA	DENOMINAZIONE	DESIGNATION	BENENNUNG	DESCRIPTION	DENOMINACIONES
1	566461	1	CUSCINETTO	ROULEMENT	LAGER	BEARING	RODAMIENTO
2	566514	1	LINGUETTA	LINGUET	SCHEIBENFEDER	KEY	CHAVETA
3	562659	14	PIASTRINA DI SICUREZZA	PLAQUETTE FREIN	SICHERUNGSBLECH	LOCKPLATE	PLACA DE FRENO
4	15970521	4	VITE	VIS	SCHRAUBE	SCREW	TORNILLO
5	566454	1	DADO	ECROU	MUTTER	NUT	TUERCA
6	566445	2	SUPPORTO	SUPPORT	LAGER	SUPPORT	SOPORTE
7	40000371	2	ANELLO DI TENUTA	JOINT D'ETANCHEITE	DICHTRING	SEAL	JUNTA HERMETICA
8	26800150	2	CUSCINETTO	ROULEMENT	LAGER	BEARING	RODAMIENTO
9	14254421	8	VITE	VIS	SCHRAUBE	SCREW	TORNILLO
10	572502	1	ALBERO	ARBRE	WELLE	SHAFT	ARBOL
11	4950071	1	COPPIA CONICA	COUPLE CONIQUE	KEGELRADANTRIEB	BEVEL GEAR./PINION SET	PAR CONICO
12	582475	-	SPESSORE DI REGISTRO	CALE D'EPAISSEUR	DISTANZSCHEIBE	SHIM	SUPLEMENTO
12	582473	-	SPESSORE DI REGISTRO 0,2	CALE D'EPAISSEUR	DISTANZSCHEIBE	SHIM	SUPLEMENTO
12	582474	-	SPESSORE DI REGISTRO 0,5	CALE D'EPAISSEUR	DISTANZSCHEIBE	SHIM	SUPLEMENTO
13	566525	1	SUPPORTO	SUPPORT	LAGER	SUPPORT	SOPORTE
14	24940210	1	CUSCINETTO	ROULEMENT	LAGER	BEARING	RODAMIENTO
15	14251621	6	VITE	VIS	SCHRAUBE	SCREW	TORNILLO
16	4991684	-	SPESSORE DI REGISTRO 1,5	CALE D'EPAISSEUR	DISTANZSCHEIBE	SHIM	SUPLEMENTO
16	4991683	-	SPESSORE DI REGISTRO 0,2	CALE D'EPAISSEUR	DISTANZSCHEIBE	SHIM	SUPLEMENTO
16	4991682	-	SPESSORE DI REGISTRO 0,5	CALE D'EPAISSEUR	DISTANZSCHEIBE	SHIM	SUPLEMENTO
17	14233421	10	VITE	VIS	SCHRAUBE	SCREW	TORNILLO
18	14234421	2	VITE	VIS	SCHRAUBE	SCREW	TORNILLO

PRESA DI FORZA POSTERIORE

*Prise de force AR.
Hintere Zapfwelle*

*Rear pto
Toma de fuerza posterior*

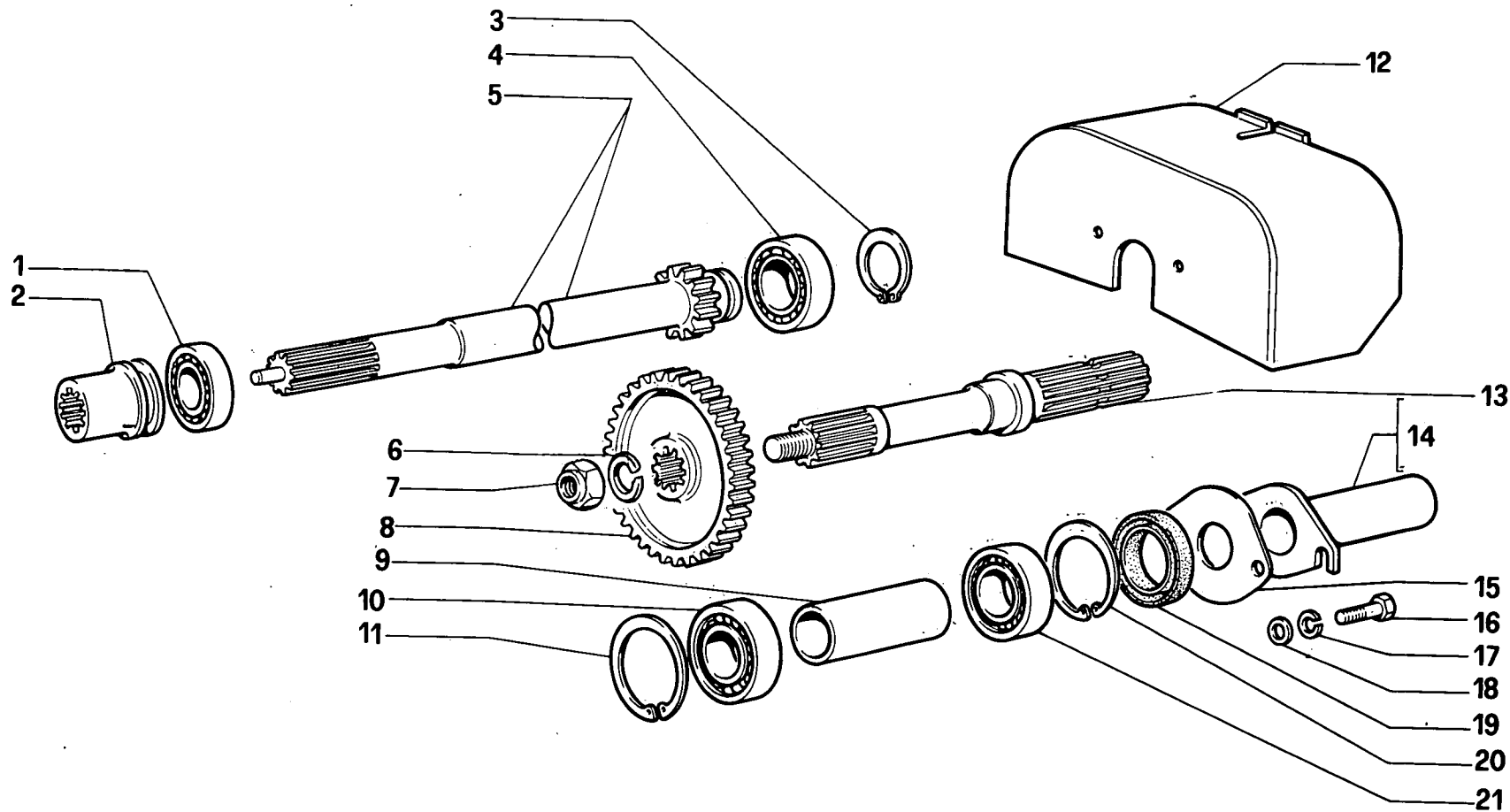

C80/50

PRESA DI FORZA

30.06/01

(09-1981)

FIG	N. ORDINAZIONE	QTA	DENOMINAZIONE	DESIGNATION	BENENNUNG	DESCRIPTION	DENOMINACIONES
1	20685450	1	CUSCINETTO	ROULEMENT	LAGER	BEARING	RODAMIENTO
2	562599	1	MANICOTTO INNESTO P.D.F.	MANCHON D'EMBRAYAGE	EINRUECKMUFFE	ENGAGING SLEEVE	MANGUITO CONEXION
3	11068876	1	ANELLO DI SICUREZZA	ARRETOIR	SICHERUNGSRING	LOCKRING	ANILLO DE FRENO
4	24974160	1	CUSCINETTO	ROULEMENT	LAGER	BEARING	RODAMIENTO
5	4970717	1	ALBERO CONDUTTORE P.D.F.	ARBRE CONDUCTEUR	TREIBENDE WELLE	DRIVING SHAFT	ARBOL CONDUCTOR
6	4960041	1	ANELLO SPALLAMENTO	BAGUE A EPAULEMENT	SCHULTERRING	RING	ANILLO CON REBORDE
7	14045271	1	DADO	ECROU	MUTTER	NUT	TUERCA
8	4970715	1	INGRANAGGIO CONDOTTO	PIGNON CONDUIT	ANGETRIEBENES ZAHNRAD	DRIVEN GEAR	PINON CONDOCIDO
9	562153	1	DISTANZIALE	ENTRETOISE	ABSTANDSTUECK	SPACER	SEPARADOR
10	20045200	1	CUSCINETTO	ROULEMENT	LAGER	BEARING	RODAMIENTO
11	11061976	1	ANELLO DI SICUREZZA	ARRETOIR	SICHERUNGSRING	LOCKRING	ANILLO DE FRENO
12	4956787	1	PROTEZIONE PRESA FORZA	GARDE PRISE FORCE	ZAPFWELLENSCHUTZ	PTO GUARD	PROTEC. TOMAFUERZA
13	4959916	1	ALBERO CONDOTTO P.D.F.	ARBRE CONDUIT	ANGETRIEBENE WELLE	DRIVEN SHAFT	ARBOL CONDOCIDO
14	5102349	1	PROTEZIONE PRESA FORZA	GARDE PRISE FORCE	ZAPFWELLENSCHUTZ	PTO GUARD	PROTEC. TOMAFUERZA
15	595686	1	PROTEZIONE	PROTECTION	ABDECKUNG	SHIELD	DEFENSA
16	16043521	2	VITE	VIS	SCHRAUBE	SCREW	TORNILLO
17	10516671	2	ROSETTA DI SICUREZZA	RONDELLE FREIN	SICHERUNGSRING	LOCKWASHER	ARANDELA DE FRENO
18	10519601	2	ROSETTA DI SICUREZZA	RONDELLE FREIN	SICHERUNGSRING	LOCKWASHER	ARANDELA DE FRENO
19	595986	1	ANELLO DI TENUTA	JOINT D'ETANCHEITE	DICHTRING	SEAL	JUNTA HERMETICA
20	11061576	1	ANELLO DI SICUREZZA	ARRETOIR	SICHERUNGSRING	LOCKRING	ANILLO DE FRENO
21	20705250	1	CUSCINETTO	ROULEMENT	LAGER	BEARING	RODAMIENTO

CEB 50

01 02 03

PULEGGIA OPERATRICE

Poulie de battage
Riemenscheibe für Nebenantriebe

Belt Pulley
Polea motriz

30.6/2

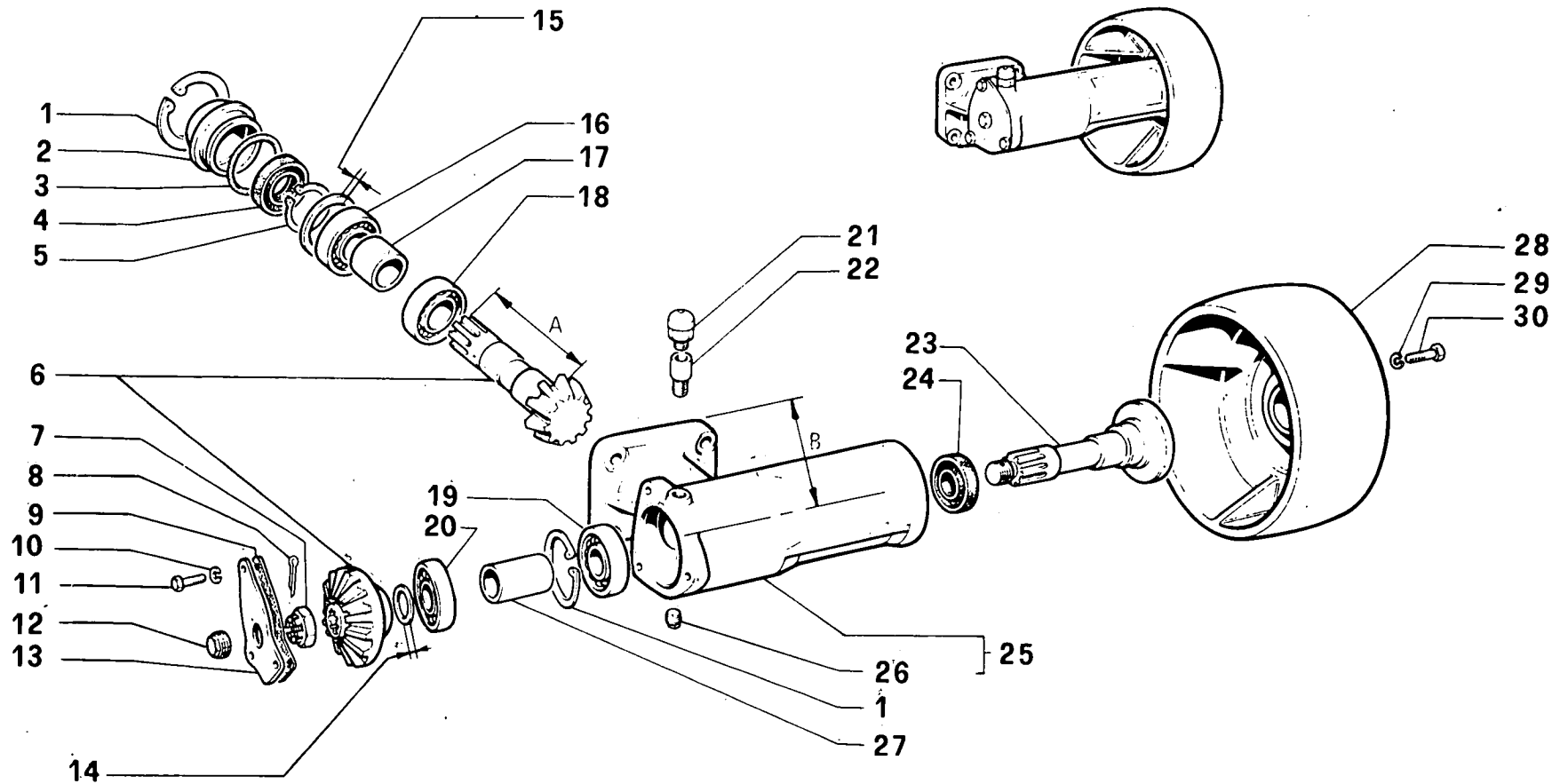

C80/50

PULEGGIA OPERATRICE

30.06/02

(09-1981)

FIG	N. ORDINAZIONE	QTA	DENOMINAZIONE	DESIGNATION	BENENNUNG	DESCRIPTION	DENOMINACIONES
	5103898	1	PULEGGIA OPERATRICE	POULIE DE BATTAGE	RIEMENSCHLEIBE FUR NEBENANTRIEBE	BELT PULLEY	POLEA MOTRIZ
1	11061976	1	ANELLO DI SICUREZZA	ARRETOIR	SICHERUNGSRING	LOCKRING	ANILLO DE FRENO
2	562131	1	COPERCHIO	COUVERCLE	DECKEL	COVER	TAPA
3	562145	1	GUARNIZIONE	GARNITURE	DICHTUNG	GASKET	JUNTA
4	5105989	1	ANELLO DI TENUTA	JOINT D'ETANCHEITE	DICHTRING	SEAL	JUNTA HERMETICA
5	11067876	1	ANELLO DI SICUREZZA	ARRETOIR	SICHERUNGSRING	LOCKRING	ANILLO DE FRENO
6	5103801	1	COPPIA CONICA	COUPLE CONIQUE	KEGELRADANTRIEB	BEVEL GEAR./PINION SET	PAR CONICO
7	560646	1	DADO	ECROU	MUTTER	NUT	TUERCA
8	10535001	1	COPIGLIA	GOUPILLE	SPLINT	SPLIT PIN	PASADOR ABIERTO
9	562132	1	GUARNIZIONE	GARNITURE	DICHTUNG	GASKET	JUNTA
10	10517671	3	ROSETTA DI SICUREZZA	RONDELLE FREIN	SICHERUNGSRING	LOCKWASHER	ARANDELA DE FRENO
11	16043221	3	VITE	VIS	SCHRAUBE	SCREW	TORNILLO
12	14324401	1	TAPPO	BOUCHON	STOPFEN	PLUG	TAPON
13	562130	1	COPERCHIO	COUVERCLE	DECKEL	COVER	TAPA
14	562140	-	SPESSORE DI REGISTRO 1,6	CALE D'EPAISSEUR	DISTANZSCHEIBE	SHIM	SUPLEMENTO
14	562141	-	SPESSORE DI REGISTRO 1,8	CALE D'EPAISSEUR	DISTANZSCHEIBE	SHIM	SUPLEMENTO
14	562142	-	SPESSORE DI REGISTRO 2	CALE D'EPAISSEUR	DISTANZSCHEIBE	SHIM	SUPLEMENTO
14	562143	-	SPESSORE DI REGISTRO 2,2	CALE D'EPAISSEUR	DISTANZSCHEIBE	SHIM	SUPLEMENTO
14	562144	-	SPESSORE DI REGISTRO 2,4	CALE D'EPAISSEUR	DISTANZSCHEIBE	SHIM	SUPLEMENTO
15	562133	-	SPESSORE DI REGISTRO 1,6	CALE D'EPAISSEUR	DISTANZSCHEIBE	SHIM	SUPLEMENTO
15	562134	-	SPESSORE DI REGISTRO 1,8	CALE D'EPAISSEUR	DISTANZSCHEIBE	SHIM	SUPLEMENTO
15	562135	-	SPESSORE DI REGISTRO 2	CALE D'EPAISSEUR	DISTANZSCHEIBE	SHIM	SUPLEMENTO
15	562136	-	SPESSORE DI REGISTRO 2,2	CALE D'EPAISSEUR	DISTANZSCHEIBE	SHIM	SUPLEMENTO
15	562137	-	SPESSORE DI REGISTRO 2,4	CALE D'EPAISSEUR	DISTANZSCHEIBE	SHIM	SUPLEMENTO

C80/50

PULEGGIA OPERATRICE

30.06/02

(09-1981)

FIG	N. ORDINAZIONE	QTA	DENOMINAZIONE	DESIGNATION	BENENNUNG	DESCRIPTION	DENOMINACIONES
16	23111990	1	CUSCINETTO	ROULEMENT	LAGER	BEARING	RODAMIENTO
17	5103800	1	DISTANZIALE	ENTRETOISE	ABSTANDSTUECK	SPACER	SEPARADOR
18	28041260	1	CUSCINETTO	ROULEMENT	LAGER	BEARING	RODAMIENTO
19	20045200	1	CUSCINETTO	ROULEMENT	LAGER	BEARING	RODAMIENTO
20	26797140	1	CUSCINETTO	ROULEMENT	LAGER	BEARING	RODAMIENTO
21	60040613	1	VITE DI SFIATO	VIS D'EVENT	ENTLUEFTUNGSSCHRAU- BE	VENT SCREW	TORNILLO DE RESPIRACION
22	560571	1	RACCORDO	RACCORD	STUTZEN	CONNECTION	RACOR
23	562129	1	ALBERO CONDOTTO	ARBRE CONDUIT	ANGETRIEBENE WELLE	DRIVEN SHAFT	ARBOL CONDUCIDO
24	5107817	1	GUARNIZIONE	GARNITURE	DICHTUNG	GASKET	JUNTA
25	5103893	1	SCATOLA COMPLETA	CARTER	GEHAUSE	CASE	CAJA
26	14324201	1	TAPPO	BOUCHON	STOPFEN	PLUG	TAPON
27	562139	1	DISTANZIALE	ENTRETOISE	ABSTANDSTUECK	SPACER	SEPARADOR
28	562126	1	PULEGGIA	POULIE	RIEMENSCHIEBE	PULLEY	POLEA
29	10517071	3	ROSETTA DI SICUREZZA	RONDELLE FREIN	SICHERUNGSRING	LOCKWASHER	ARANDELA DE FRENO
30	10935521	3	VITE	VIS	SCHRAUBE	SCREW	TORNILLO

CB50

01 02 03

SCATOLE RIDUTTORI LATERALI POSTERIORI

Carters de réducteurs latéraux AR

Gehäuse der hinteren Endantriebe

Rear Side Final Drive Cases

Cajas de reductores laterales posteriores

40.4/1

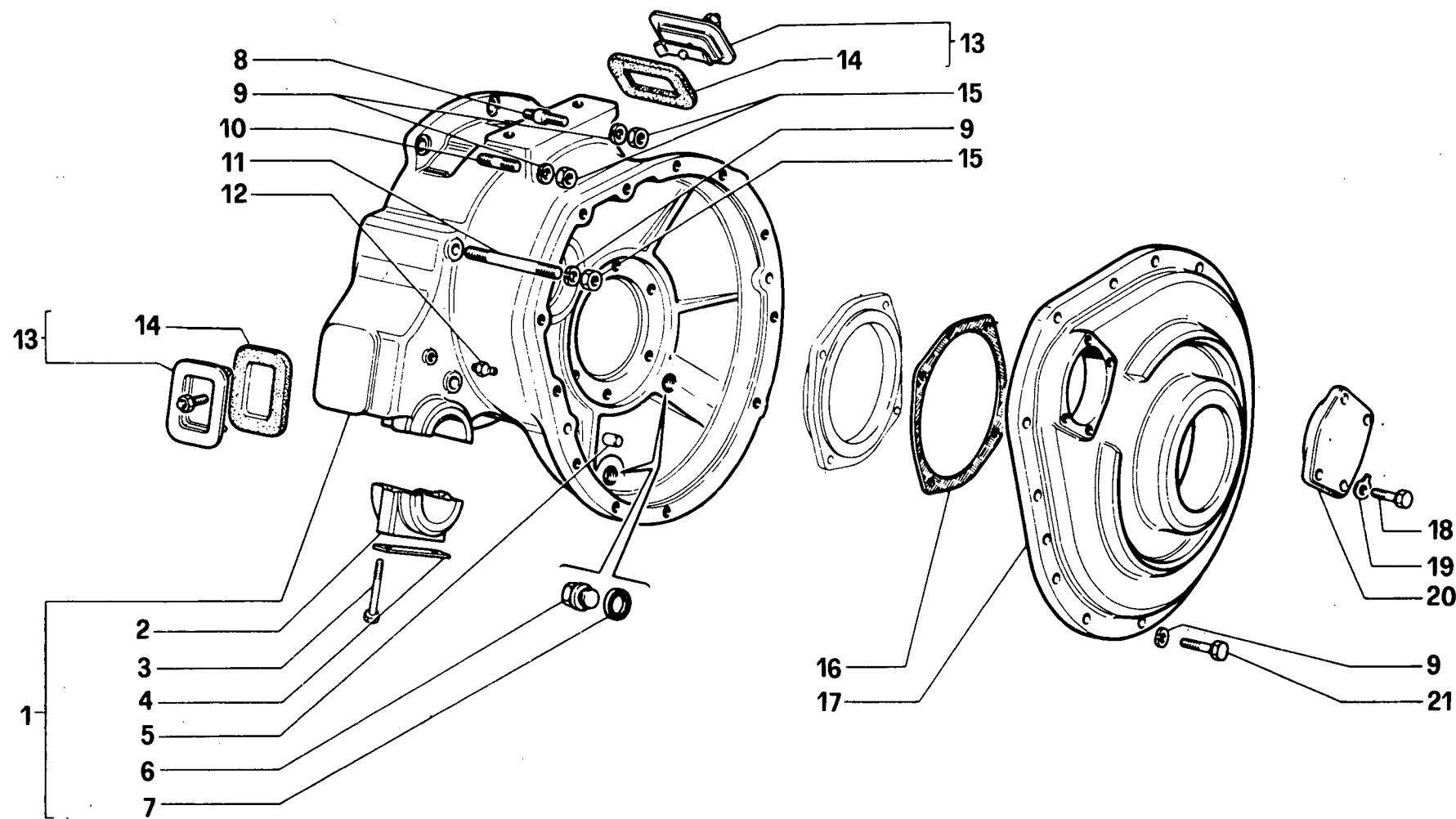

C80/50

PONTE POSTERIORE

40.04/01

(09-1981)

FIG	N. ORDINAZIONE	QTA	DENOMINAZIONE	DESIGNATION	BENENNUNG	DESCRIPTION	DENOMINACIONES
1	4970273	1	SCATOLA RIDUTTORE DX (01)	CARTER	GEHAUSE	CASE	CAJA
1	4969575	1	SCATOLA RIDUTTORE DX (02)	CARTER	GEHAUSE	CASE	CAJA
1	4970275	1	SCATOLA RIDUTTORE DX (03)	CARTER	GEHAUSE	CASE	CAJA
1	595770	1	SCATOLA RIDUTTORE SX (01)	CARTER	GEHAUSE	CASE	CAJA
1	595774	1	SCATOLA RIDUTTORE SX (02)	CARTER	GEHAUSE	CASE	CAJA
1	595778	1	SCATOLA RIDUTTORE SX (03)	CARTER	GEHAUSE	CASE	CAJA
2	4953207	2	SUPPORTO	SUPPORT	LAGER	SUPPORT	SOPORTE
3	11254121	4	VITE	VIS	SCHRAUBE	SCREW	TORNILLO
4	572370	2	PIASTRINA	PLAQUETTE	PLAETTCHEN	PLATE	PLACA
5	10839810	4	SPINA (03)	GOUPILLE	STIFT	PIN	PASADOR
5	10839910	4	SPINA (01-02)	GOUPILLE	STIFT	PIN	PASADOR
6	10305171	4	TAPPO	BOUCHON	STOPFEN	PLUG	TAPON
7	10263460	4	GUARNIZIONE DI TENUTA	JOINT	DICHTUNG	GASKET	JUNTA
8	4953417	2	PRIGIONIERO	GOUJON	STIFTSCHRAUBE	STUD	ESPARRAGO
9	10517071	46	ROSETTA DI SICUREZZA	RONDELLE FREIN	SICHERUNGSRING	LOCKWASHER	ARANDELA DE FRENO
10	11794620	14	PRIGIONIERO	GOUJON	STIFTSCHRAUBE	STUD	ESPARRAGO
11	11796320	4	PRIGIONIERO	GOUJON	STIFTSCHRAUBE	STUD	ESPARRAGO
12	13407211	2	INGRASSATORE	GRAISSER	SCHMIERNIPPEL	FITTING	ENGRASADOR
13	569683	2	COPERCHIO	COUVERCLE	DECKEL	COVER	TAPA
14	564603	2	GUARNIZIONE	GARNITURE	DICHTUNG	GASKET	JUNTA
15	10790311	20	DADO (01-02)	ECROU	MUTTER	NUT	TUERCA
15	12163911	20	DADO (03)	ECROU	MUTTER	NUT	TUERCA
16	554264	2	GUARNIZIONE	GARNITURE	DICHTUNG	GASKET	JUNTA
17	5102303	2	COPERCHIO (01-02)	COUVERCLE	DECKEL	COVER	TAPA
17	551919	2	COPERCHIO (03)	COUVERCLE	DECKEL	COVER	TAPA
18	15970721	8	VITE (03)	VIS	SCHRAUBE	SCREW	TORNILLO
19	10053610	8	PIASTRINA DI SICUREZZA (03)	PLAQUETTE FREIN	SICHERUNGSBLECH	LOCKPLATE	PLACA DE FRENO
20	539203	2	COPERCHIO (03)	COUVERCLE	DECKEL	COVER	TAPA
21	11306921	26	VITE	VIS	SCHRAUBE	SCREW	TORNILLO

CEB.50

01 02

RIDUTTORI LATERALI POSTERIORI

Réducteurs latéraux AR.

Wellen der hinteren Endantriebe

Rear side final drive

Reductores laterales posteriores

40.7/1

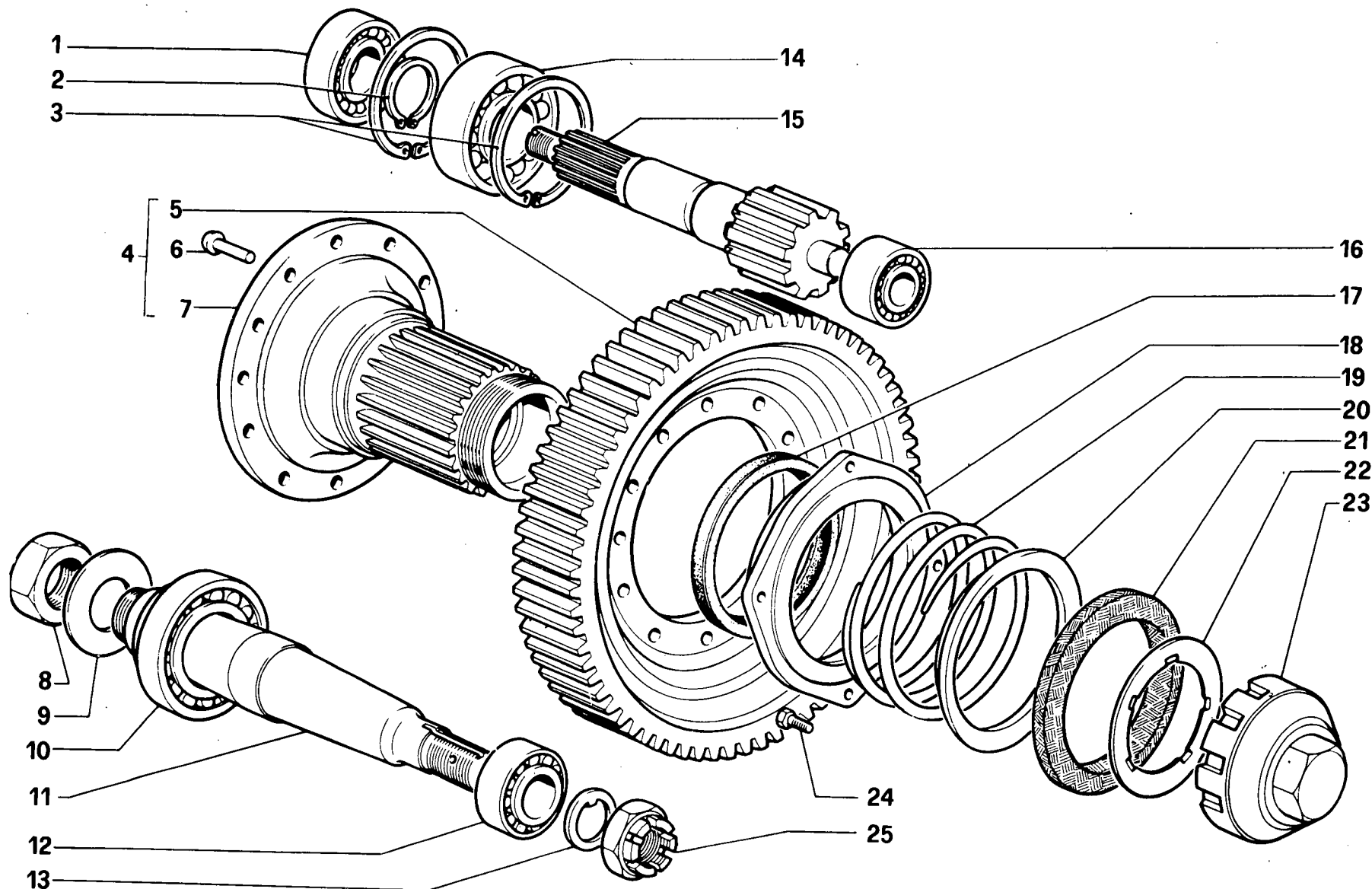

C80/50

RIDUTTORI LATERALI POSTERIORI

40.07/01

(09-1981)

FIG	N. ORDINAZIONE	QTA	DENOMINAZIONE	DESIGNATION	BENENNUNG	DESCRIPTION	DENOMINACIONES
1	20943310	2	CUSCINETTO	ROULEMENT	LAGER	BEARING	RODAMIENTO
2	11069376	2	ANELLO DI SICUREZZA	ARRETOIR	SICHERUNGSRING	LOCKRING	ANILLO DE FRENO
3	11075476	2	ANELLO DI SICUREZZA	ARRETOIR	SICHERUNGSRING	LOCKRING	ANILLO DE FRENO
4	541727	2	INGRANAGGIO CONDOTTO	PIGNON CONDUIT	ANGETRIEBENES ZAHNRAD	DRIVEN GEAR	PINON CONDUCIDO
5	538333	2	CORONA DENTATA	COURONNE DENTEE	ZAHNKRANZ	RING GEAR	CORONA DENTADA
6	10538400	24	CHiodo A BOTTONE	CLOU A BOUTON	KNOPFNAGEL	BUTTON NAIL	CLAVO BOTON
6	10538500	-	CHiodo A BOTTONE	CLOU A BOUTON	KNOPFNAGEL	BUTTON NAIL	CLAVO BOTON
7	538332	2	MOZZO RUOTA	MOYEU	RADNABE	WHEEL HUB	CUBO RUEDA
8	536570	2	DADO	ECROU	MUTTER	NUT	TUERCA
9	553386	2	ROSETTA PIANA	RONDELLE	SCHEIBE	WASHER	ARANDELA
10	26800000	2	CUSCINETTO	ROULEMENT	LAGER	BEARING	RODAMIENTO
11	5101777	2	ALBERO CONDOTTO	ARBRE CONDUIT	ANGETRIEBENE WELLE	DRIVEN SHAFT	ARBOL CONDUCIDO
12	26800130	2	CUSCINETTO	ROULEMENT	LAGER	BEARING	RODAMIENTO
13	536572	2	ROSETTA DI SICUREZZA	RONDELLE FREIN	SICHERUNGSRING	LOCKWASHER	ARANDELA DE FRENO
14	20229990	2	CUSCINETTO	ROULEMENT	LAGER	BEARING	RODAMIENTO
15	4953364	2	ALBERO CONDOTTO (01)	ARBRE CONDUIT	ANGETRIEBENE WELLE	DRIVEN SHAFT	ARBOL CONDUCIDO
15	4953365	2	ALBERO CONDOTTO (02)	ARBRE CONDUIT	ANGETRIEBENE WELLE	DRIVEN SHAFT	ARBOL CONDUCIDO
16	24900510	2	CUSCINETTO	ROULEMENT	LAGER	BEARING	RODAMIENTO
17	5109079	2	ANELLO DI TENUTA	JOINT D'ETANCHEITE	DICHTRING	SEAL	JUNTA HERMETICA
18	538335	2	FLANGIA	BRIDE	FLANSCH	FLANGE	BRIDA
19	538338	2	MOLLA	RESSORT	FEDER	SPRING	RESORTE
20	551982	2	PREMIGUARNIZIONE	PRESSE-JOINT	DRUCKFEDER	EXPANDER	ELEMENTO SEPARADOR
21	538337	2	GUARNIZIONE	GARNITURE	DICHTUNG	GASKET	JUNTA
22	556412	2	ROSETTA DI SICUREZZA	RONDELLE FREIN	SICHERUNGSRING	LOCKWASHER	ARANDELA DE FRENO
23	570542	2	COPERCHIO	COUVERCLE	DECKEL	COVER	TAPA
24	14238021	8	VITE	VIS	SCHRAUBE	SCREW	TORNILLO
25	547517	2	DADO	ECROU	MUTTER	NUT	TUERCA

RUOTISMI RIDUTTORI LATERALI POSTERIORI

*Engrenages de réducteurs latéraux AR
Zahnräder und Wellen der hinteren Endantriebe*

*Rear Side Final Drive Gears
Engranajes de reductores laterales posteriores*

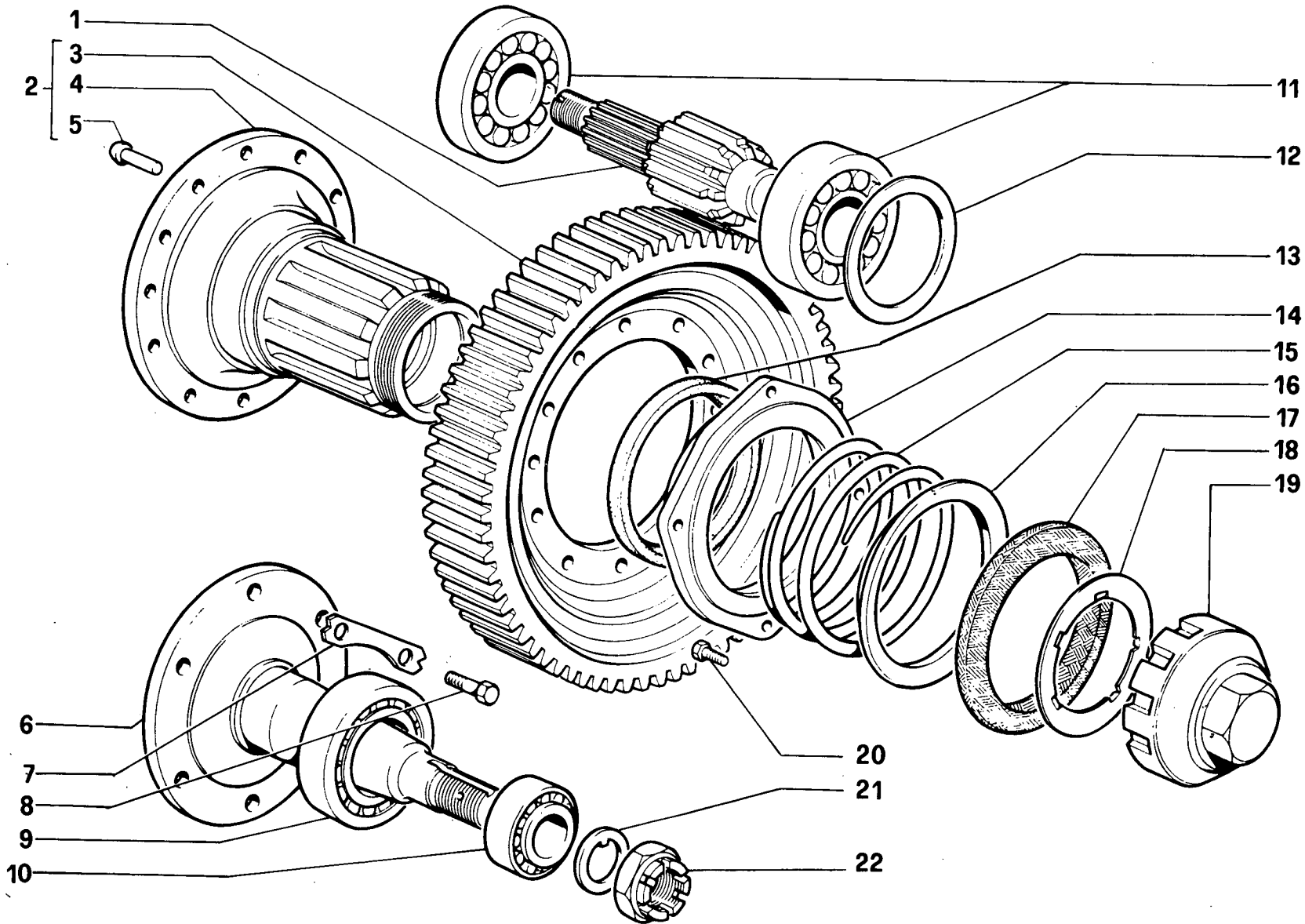

C80/50

RIDUTTORI LATERALI. POSTERIORI

40.07/02

(09-1981)

FIG	N. ORDINAZIONE	QTA	DENOMINAZIONE	DESIGNATION	BENENNUNG	DESCRIPTION	DENOMINACIONES
1	4953366	2	ALBERO CONDOTTO	ARBRE CONDUIT	ANGETRIEBENE WELLE	DRIVEN SHAFT	ARBOL CONDUcido
2	543458	2	INGRANAGGIO CONDOTTO	PIGNON CONDUIT	ANGETRIEBENES ZAHNRAD	DRIVEN GEAR	PINON CONDUcido
3	539197	2	CORONA DENTATA INGRANAGGIO RIDUTTORE	COURONNE DENTEE	ZAHNKRANZ	RING GEAR	CORONA DENTADA
4	538332	2	MOZZO RUOTA	MOYEU	RADNABE	WHEEL HUB	CUBO RUEDA
5	10538500	24	CHiodo A BOTTONe	CLOU A BOUTON	KNOPFNAGEL	BUTTON NAIL	CLAVO BOTON
6	5101778	2	ALBERO CONDOTTO	ARBRE CONDUIT	ANGETRIEBENE WELLE	DRIVEN SHAFT	ARBOL CONDUcido
7	557311	6	PIASTRINA DI SICUREZZA	PLAQUETTE FREIN	SICHERUNGSBLECH	LOCKPLATE	PLACA DE FRENO
8	15864421	12	VITE	VIS	SCHRAUBE	SCREW	TORNILLO
9	26800000	2	CUSCINETTO	ROULEMENT	LAGER	BEARING	RODAMIENTO
10	26800130	2	CUSCINETTO	ROULEMENT	LAGER	BEARING	RODAMIENTO
11	26800360	4	CUSCINETTO	ROULEMENT	LAGER	BEARING	RODAMIENTO
12	539207	-	SPESSORE DI REGISTRO MM 0,3	CALE D'EPAlSSEUR	DISTANZSCHEIBE	SHIM	SUPLEMENTO
12	4983527	-	SPESSORE DI REGISTRO MM 0,5	CALE D'EPAlSSEUR	DISTANZSCHEIBE	SHIM	SUPLEMENTO
12	4983528	-	SPESSORE DI REGISTRO MM 1	CALE D'EPAlSSEUR	DISTANZSCHEIBE	SHIM	SUPLEMENTO
13	5109079	2	ANELLO DI TENUZA	JOINT D'ETANCHEITE	DICHTRING	SEAL	JUNTA HERMETICA
14	538335	2	FLANGIA	BRIDE	FLANSCH	FLANGE	BRIDA
15	538338	2	MOLLA	RESSORT	FEDER	SPRING	RESORTE
16	551982	2	PREMIGUARNIZIONE	PRESSE-JOINT	DRUCKFEDER	EXPANDER	ELEMENTO SEPARADOR
17	538337	2	GUARNIZIONE	GARNITURE	DICHTUNG	GASKET	JUNTA
18	556412	2	ROSETTA DI SICUREZZA	RONDELLE FREIN	SICHERUNGSRING	LOCKWASHER	ARANDELA DE FRENO
19	570542	2	COPERCHIO	COUVERCLE	DECKEL	COVER	TAPA
20	14238021	2	VITE	VIS	SCHRAUBE	SCREW	TORNILLO
21	536572	2	ROSETTA DI SICUREZZA	RONDELLE FREIN	SICHERUNGSRING	LOCKWASHER	ARANDELA DE FRENO
22	547517	2	DADO	ECROU	MUTTER	NUT	TUERCA

SOSPENSIONE ANTERIORE

Suspension AV
Vorderradaufhängung

Front Suspension
Suspensión anterior

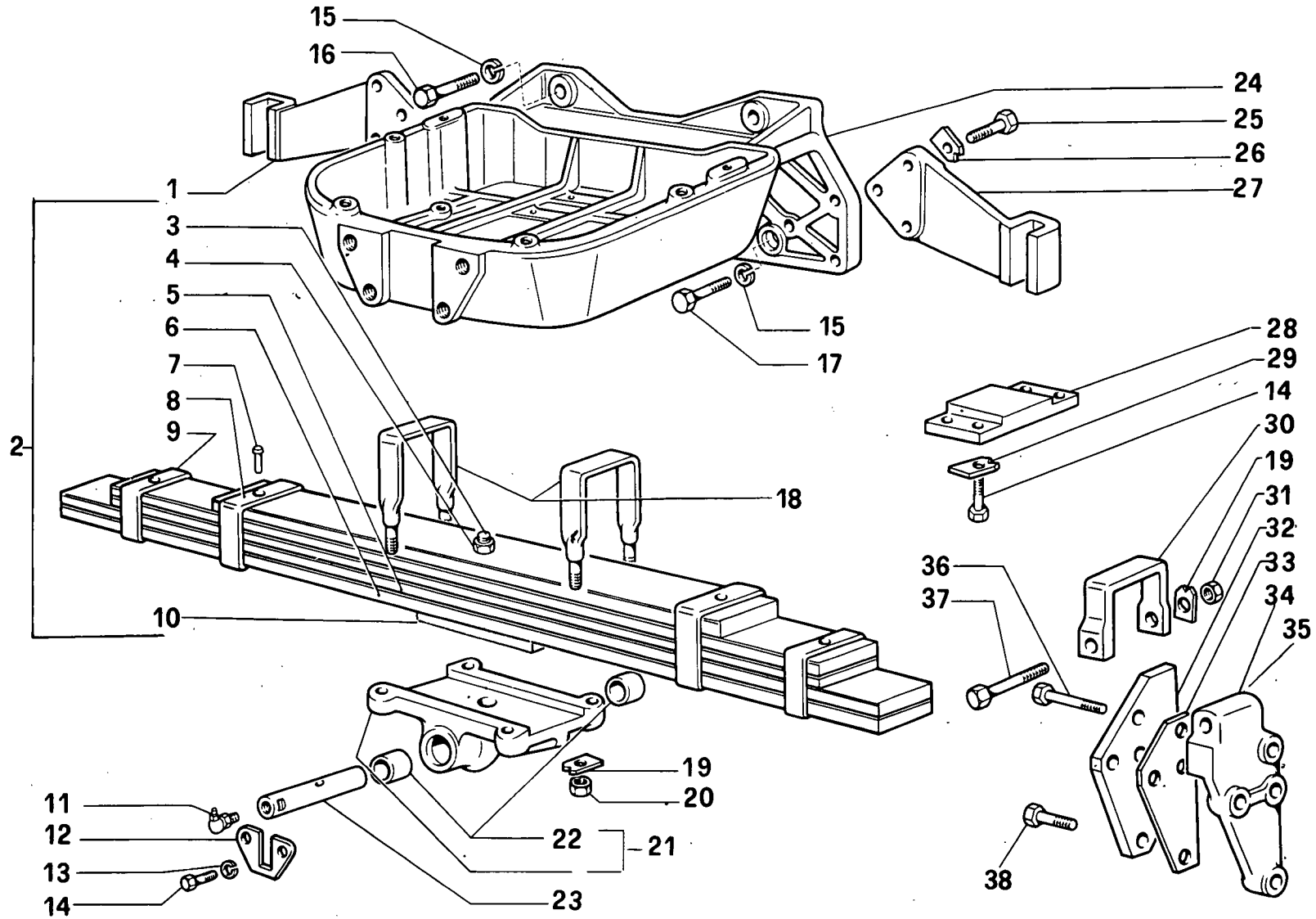

C80/50

SOSPENSIONE ANTERIORE

50.01/01

(09-1981)

FIG	N. ORDINAZIONE	QTA	DENOMINAZIONE	DESIGNATION	BENENNUNG	DESCRIPTION	DENOMINACIONES
1	4960986	1	SUPPORTO DX (01)	SUPPORT	LAGER	SUPPORT	SOPORTE
1	4960988	1	SUPPORTO DX (02)	SUPPORT	LAGER	SUPPORT	SOPORTE
1	584989	1	SUPPORTO DX (03)	SUPPORT	LAGER	SUPPORT	SOPORTE
2	4961052	1	MOLLA A BALESTRA (01)	RESSORT A LAMES	BLATTFEDER	LEAF SPRING	BALLESTA
2	4964324	1	MOLLA A BALESTRA (02)	RESSORT A LAMES	BLATTFEDER	LEAF SPRING	BALLESTA
2	599717	1	MOLLA A BALESTRA (03)	RESSORT A LAMES	BLATTFEDER	LEAF SPRING	BALLESTA
3	568238	1	VITE	VIS	SCHRAUBE	SCREW	TORNILLO
4	10791011	1	DADO	ECROU	MUTTER	NUT	TUERCA
5	4964326	1	LAMA BALESTRA (02)	LAME	BLATTEFEDER	LEAF	HOJA
6	4961053	1	LAMA BALESTRA (01)	LAME	BLATTEFEDER	LEAF	HOJA
6	4964325	1	LAMA BALESTRA (02)	LAME	BLATTEFEDER	LEAF	HOJA
6	4952977	1	LAMA BALESTRA (03)	LAME	BLATTEFEDER	LEAF	HOJA
7	10545700	1	RIBATTINO	RIVET	NIET	RIVET	REMACHE
8	4954430	2	STAFFA (01-03)	ETRIER	HALTER	BRACKET	SOPORTE
8	4964334	2	STAFFA (02)	ETRIER	HALTER	BRACKET	SOPORTE
9	4964333	2	STAFFA (02)	ETRIER	HALTER	BRACKET	SOPORTE
10	4961134	1	PIASTRA (01-03)	PLAQUE	PLATTE	PLATE	PLACA
11	13408411	1	INGRASSATORE	GRAISSER	SCHMIERNIPPEL	FITTING	ENGRASADOR
12	596219	1	PIASTRINA	PLAQUETTE	PLAETTCHEN	PLATE	PLACA
13	10516871	2	ROSETTA DI SICUREZZA	RONDELLE FREIN	SICHERUNGSRING	LOCKWASHER	ARANDELA DE FRENO
14	15970721	6	VITE	VIS	SCHRAUBE	SCREW	TORNILLO
15	10517271	4	ROSETTA DI SICUREZZA	RONDELLE FREIN	SICHERUNGSRING	LOCKWASHER	ARANDELA DE FRENO
16	15981031	2	VITE	VIS	SCHRAUBE	SCREW	TORNILLO
17	15981231	2	VITE	VIS	SCHRAUBE	SCREW	TORNILLO
18	4953409	2	STAFFA	ETRIER	HALTER	BRACKET	SOPORTE
19	14198910	6	PIASTRINA DI SICUREZZA	PLAQUETTE FREIN	SICHERUNGSBLECH	LOCKPLATE	PLACA DE FRENO
20	4952523	4	DADO	ECROU	MUTTER	NUT	TUERCA
21	596216	1	PIASTRA COMPL.	PLAQUE	PLATTE	PLATE	PLACA
22	568896	2	BOCCOLA	DOUILLE	BUECHSE	BUSH	CASQUILLO
23	596218	1	PERNO	AXE	BOLZEN	PIN	EJE
24	599098	1	SUPPORTO	SUPPORT	LAGER	SUPPORT	SOPORTE
25	11390521	6	VITE	VIS	SCHRAUBE	SCREW	TORNILLO
26	14199110	6	PIASTRINA	PLAQUETTE	PLAETTCHEN	PLATE	PLACA
27	4960987	1	SUPPORTO SX (01)	SUPPORT	LAGER	SUPPORT	SOPORTE
27	4960989	1	SUPPORTO SX (02)	SUPPORT	LAGER	SUPPORT	SOPORTE

CB50

01.02.03

SOSPENSIONE ANTERIORE

Suspension AV
Vorderradaufhängung

Front Suspension
Suspensión anterior

50.1/1

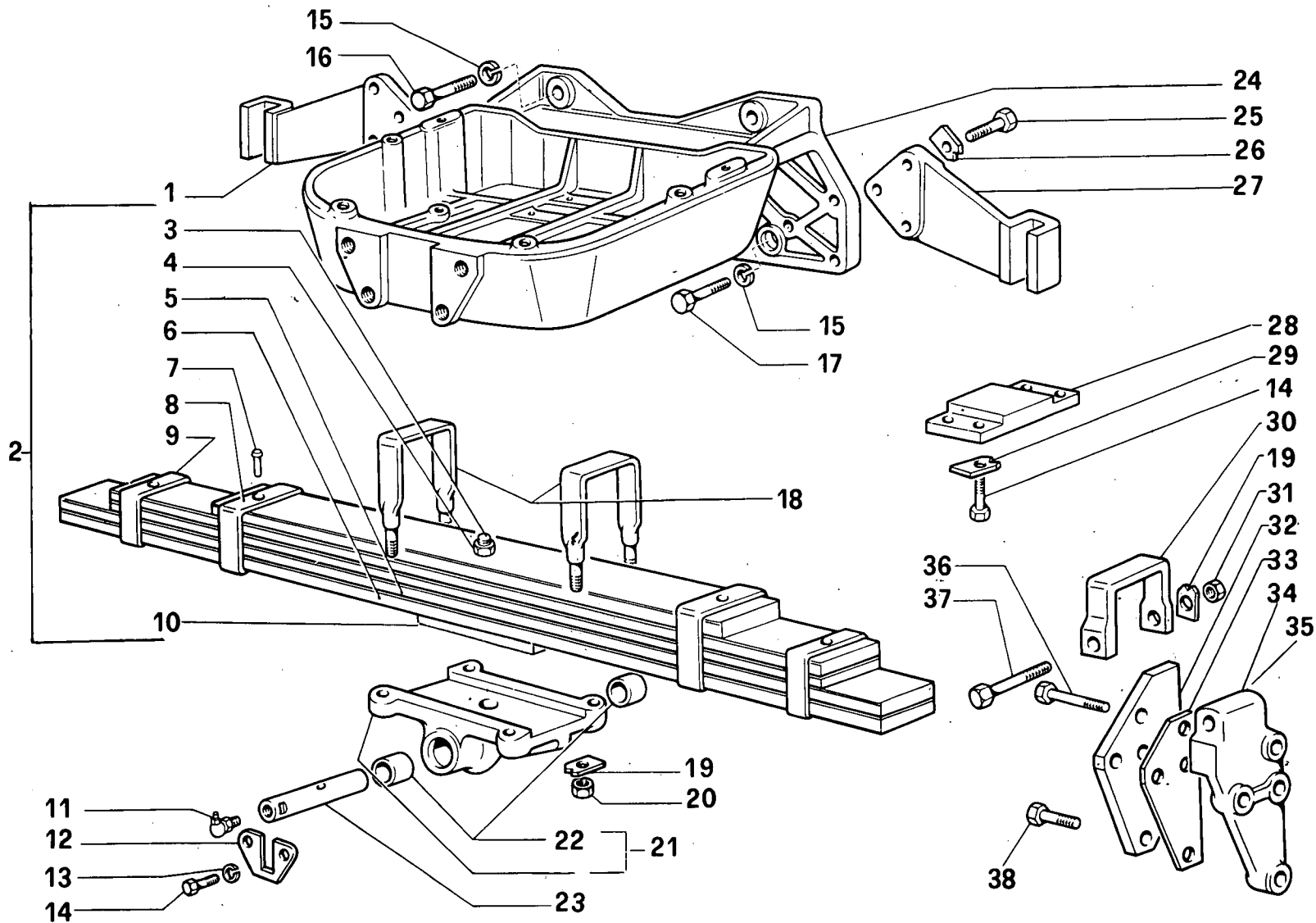

C80/50

SOSPENSIONE ANTERIORE

50.01/01

(09-1981)

FIG	N. ORDINAZIONE	QTA	DENOMINAZIONE	DESIGNATION	BENENNUNG	DESCRIPTION	DENOMINACIONES
27	584990	1	SUPPORTO SX (03)	SUPPORT	LAGER	SUPPORT	SOPORTE
28	596217	1	PIASTRA	PLAQUE	PLATTE	PLATE	PLACA
29	14198810	4	PIASTRINA DI SICUREZZA	PLAQUETTE FREIN	SICHERUNGSBLECH	LOCKPLATE	PLACA DE FRENO
30	566665	2	TASSELLO	TAMPON	BEILAGE	PAD	TACO
31	16103611	2	DADO	ECROU	MUTTER	NUT	TUERCA
32	4955386	2	PIASTRA	PLAQUE	PLATTE	PLATE	PLACA
33	599624	8	SPESSORE DI REGISTRO	CALE D'EPAILSEUR	DISTANZSCHEIBE	SHIM	SUPLEMENTO
34	599757	1	PATTINO DX	PATIN	GLEITSTEIN	PAD	PATIN
35	599758	1	PATTINO SX	PATIN	GLEITSTEIN	PAD	PATIN
36	14254530	2	VITE	VIS	SCHRAUBE	SCREW	TORNILLO
37	15541521	2	VITE	VIS	SCHRAUBE	SCREW	TORNILLO
38	14255030	6	VITE	VIS	SCHRAUBE	SCREW	TORNILLO

CB0.50

01 02 03

SUPPORTO ANTERIORE

Berceau essieu - Cloche de volant
Achslagerbock - Schwungradglocke

Axle bracket - Bell housing
Caballete P. eje - Campana volante

50.2/1

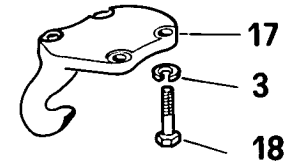
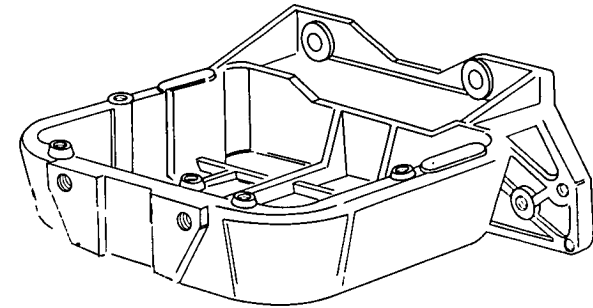
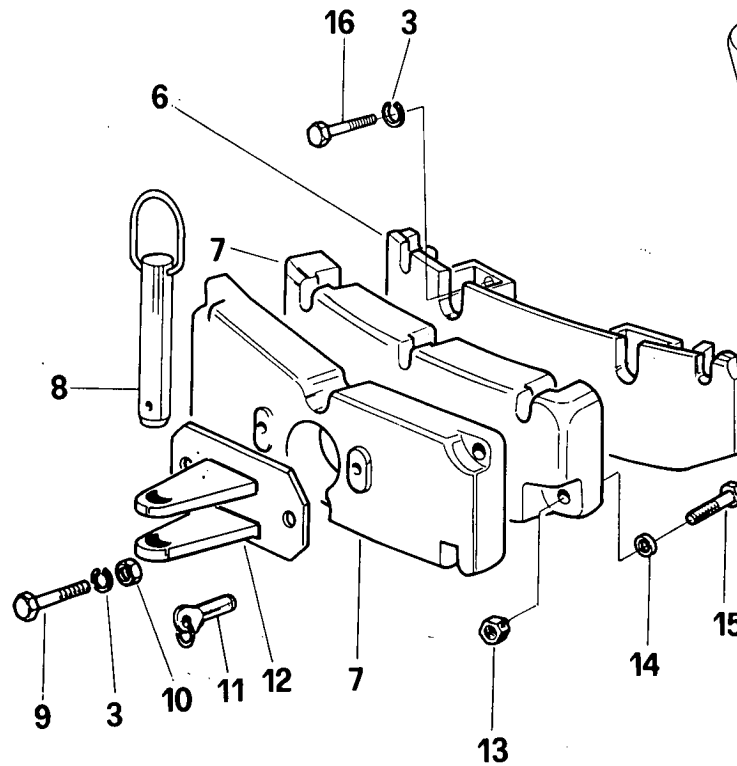
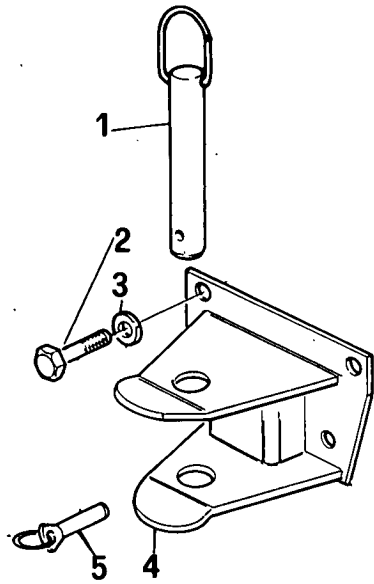

C80/50

SUPPORTO ANTERIORE

50.02/01

(09-1981)

FIG	N. ORDINAZIONE	QTA	DENOMINAZIONE	DESIGNATION	BENENNUNG	DESCRIPTION	DENOMINACIONES
1	587080	1	PERNO X GANCIO	AXE	BOLZEN	PIN	EJE
2	11390521	4	VITE	VIS	SCHRAUBE	SCREW	TORNILLO
3	10517270	14	ROSETTA DI SICUREZZA	RONDELLE FREIN	SICHERUNGSRING	LOCKWASHER	ARANDELA DE FRENO
4	4966283	1	GANCIO DI TRAINO ANTERIORE	CHAPE DE REFOULEMENT AV	VORDERER ABSCHLEPPHAKEN	PULL HOOK	ENGANCHE DE REMOLQUE ANTERIOR
5	4967704	1	SPINA	GOUPILLE	STIFT	PIN	PASADOR
6	599587	1	SUPPORTO ZAVORRE	SUPPORT	LAGER	SUPPORT	SOPORTE
7	592063	3	ZAVORRA	LEST	ZUSATZGEWICHT	BALLAST	LASTRE
8	573185	1	PERNO X GANCIO	AXE	BOLZEN	PIN	EJE
9	15835221	2	VITE	VIS	SCHRAUBE	SCREW	TORNILLO
10	12164111	6	DADO	ECROU	MUTTER	NUT	TUERCA
11	567406	1	SPINA	GOUPILLE	STIFT	PIN	PASADOR
12	592064	1	GANCIO DI TRAINO ANTERIORE	CHAPE DE REFOULEMENT AV	VORDERER ABSCHLEPPHAKEN	PULL HOOK	ENGANCHE DE REMOLQUE ANTERIOR
13	12164011	9	DADO	ECROU	MUTTER	NUT	TUERCA
14	10517170	9	ROSETTA DI SICUREZZA	RONDELLE FREIN	SICHERUNGSRING	LOCKWASHER	ARANDELA DE FRENO
15	562480	9	VITE	VIS	SCHRAUBE	SCREW	TORNILLO
16	11376221	4	VITE	VIS	SCHRAUBE	SCREW	TORNILLO
17	562830	1	GANCIO DI MANOVRA	CROCHET	HAKEN	HOOK	GANCHO
18	15540521	4	VITE	VIS	SCHRAUBE	SCREW	TORNILLO

C80.50
01 02 03

CORPO CARRELLO CINGOLO

Châssis de chariot de chenille
Laufwerkrahmen

Track Frame Body
Armazón de cadena

50.3/1

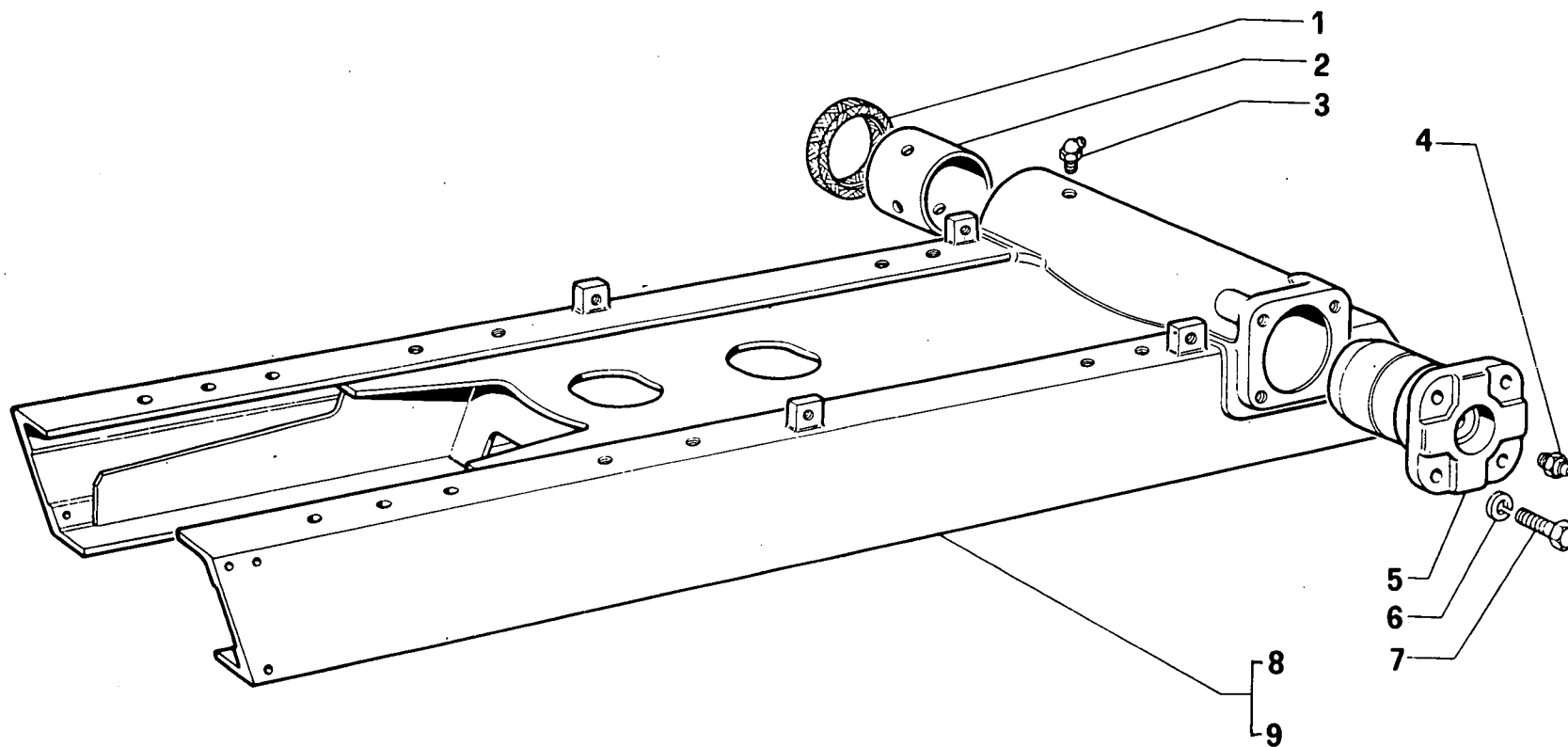

C80/50

CORPO CARRELLO CINGOLO

50.03/01

(09-1981)

FIG	N. ORDINAZIONE	QTA	DENOMINAZIONE	DESIGNATION	BENENNUNG	DESCRIPTION	DENOMINACIONES
1	4960954	2	GUARNIZIONE	GARNITURE	DICHTUNG	GASKET	JUNTA
2	4960953	2	BOCCOLA	DOUILLE	BUECHSE	BUSH	CASQUILLO
3	13407811	2	INGRASSATORE	GRAISSER	SCHMIERNIPPEL	FITTING	ENGRASADOR
4	13407211	2	INGRASSATORE	GRAISSER	SCHMIERNIPPEL	FITTING	ENGRASADOR
5	4960958	2	COPERCHIO	COUVERCLE	DECKEL	COVER	TAPA
6	10517071	8	ROSETTA DI SICUREZZA	RONDELLE FREIN	SICHERUNGSRING	LOCKWASHER	ARANDELA DE FRENO
7	15540521	8	VITE	VIS	SCHRAUBE	SCREW	TORNILLO
8	5114572	1	CORPO CARRELLO CINGOLO DX	CHASSIS DE CHARIOT, DE CHENILLE	LAUFWERKRAHMEN	TRACK FRAME BODY	ARMAZON DE CADENA
9	5114573	1	CORPO CARRELLO CINGOLO SX	CHASSIS DE CHARIOT DE CHENILLE	LAUFWERKRAHMEN	TRACK FRAME BODY	ARMAZON DE CADENA

CEB 50

01 02 03

SOSPENSIONE POSTERIORE

Suspension AR
Hinterradaufhängung

Rear Suspension
Suspensión posterior

50.3/2

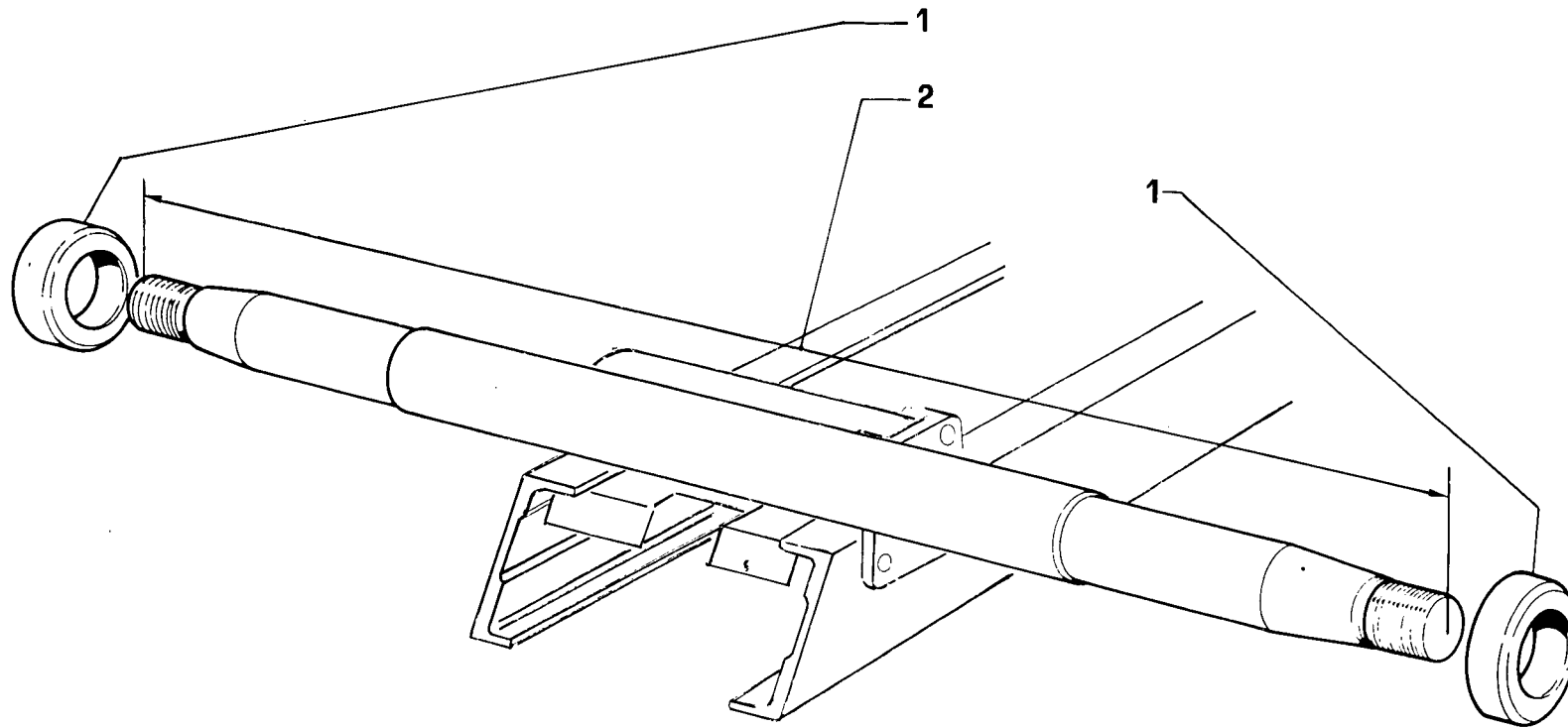

C80/50

SOSPENSIONE POSTERIORE

50.03/02

(09-1981)

FIG	N. ORDINAZIONE	QTA	DENOMINAZIONE	DESIGNATION	BENENNUNG	DESCRIPTION	DENOMINACIONES
1	4960985	2	DISTANZIALE (03)	ENTRETOISE	ABSTANDSTUECK	SPACER	SEPARADOR
2	4961064	1	BARRA DI ACCOPPIA- MENTO TRASVERSALE (01)	BARRE D'ACCOUPLE- M.	KUPPLUNGSSTANGE	ROD	BARRA ACOPLAM.
2	4961078	1	BARRA DI ACCOPPIA- MENTO TRASVERSALE (02)	BARRE D'ACCOUPLE- M.	KUPPLUNGSSTANGE	ROD	BARRA ACOPLAM.
2	4961065	1	BARRA DI ACCOPPIA- MENTO TRASVERSALE (03)	BARRE D'ACCOUPLE- M.	KUPPLUNGSSTANGE	ROD	BARRA ACOPLAM.

CB0.50

01 02 03

FRENI

Freins
Brems

Brakes
Freno

50.4/1

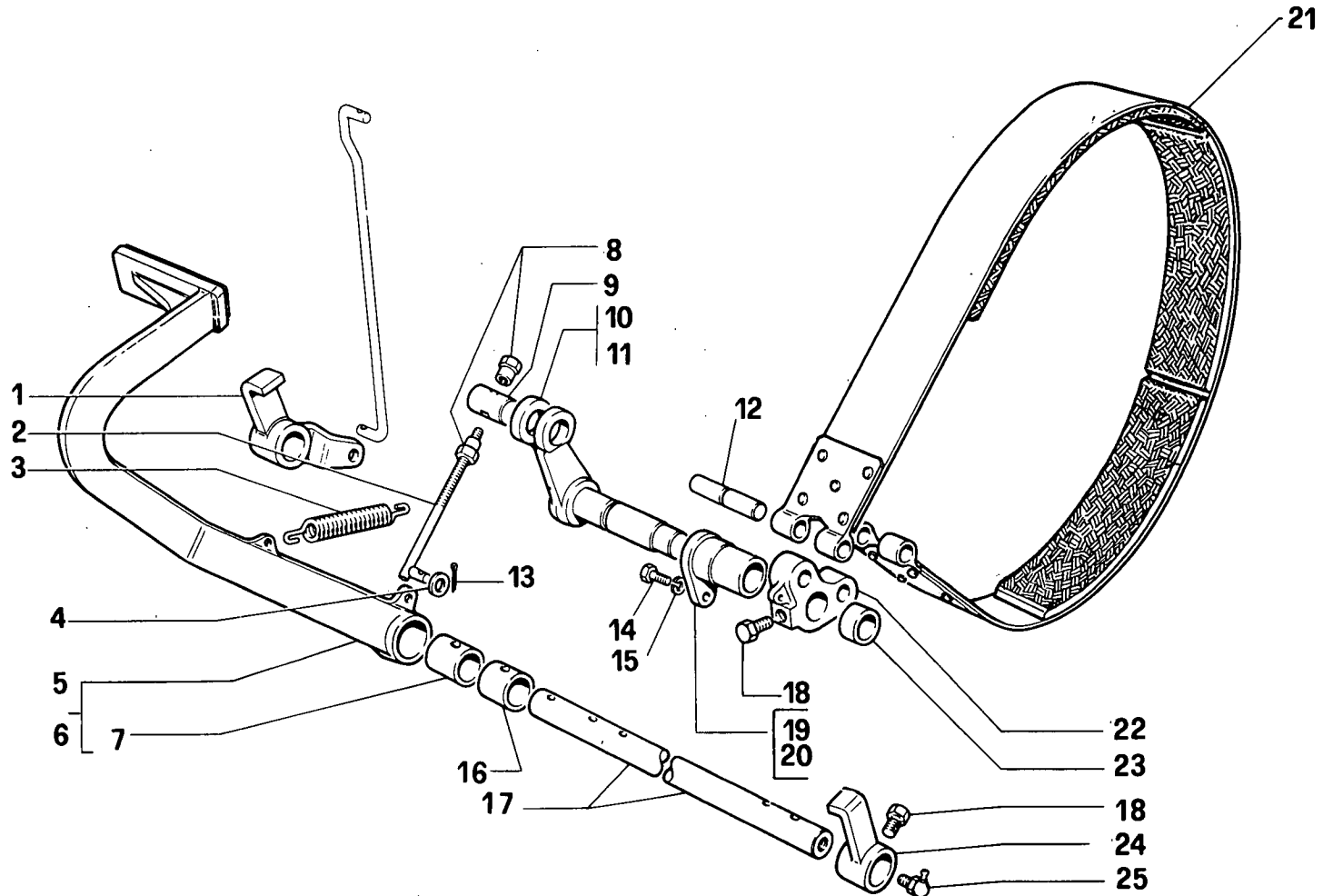

C80/50

FRENI

50.04/01

(09-1981)

FIG	N. ORDINAZIONE	QTA	DENOMINAZIONE	DESIGNATION	BENENNUNG	DESCRIPTION	DENOMINACIONES
1	4975198	1	LEVA DX	LEVIER	HEBEL	LEVER	PALANCA
2	5103306	2	TIRANTE FRENI COMPL.	TIRANT	STANGE	ROD	VARILLA
3	559627	2	MOLLA	RESSORT	FEDER	SPRING	RESORTE
4	10520001	2	ROSETTA PIANA	RONDELLE	SCHLEIBE	WASHER	ARANDELA
5	5103288	1	PEDALE FRENO DX	PEDALE DE FREIN	BREMSPEDAL	BRAKE PEDAL	PEDAL FRENO
6	5103289	1	PEDALE FRENO SX	PEDALE DE FREIN	BREMSPEDAL	BRAKE PEDAL	PEDAL FRENO
7	4958507	1	BOCCOLA	DOUILLE	BUECHSE	BUSH	CASQUILLO
8	4957353	4	DADO	ECROU	MUTTER	NUT	TUERCA
9	4957350	2	PERNO	AXE	BOLZEN	PIN	EJE
10	5109321	1	LEVA DX COMPL.	LEVIER	HEBEL	LEVER	PALANCA
11	5109322	1	LEVA SX COMPL.	LEVIER	HEBEL	LEVER	PALANCA
12	562187	4	PERNO	AXE	BOLZEN	PIN	EJE
13	10796401	2	COPIGLIA	GOUPILLE	SPLINT	SPLIT PIN	PASADOR ABIERTO
14	16043421	2	VITE	VIS	SCHRAUBE	SCREW	TORNILLO
15	10516671	2	ROSETTA DI SICUREZZA	RONDELLE FREIN	SICHERUNGSRING	LOCKWASHER	ARANDELA DE FRENO
16	4958508	2	BOCCOLA	DOUILLE	BUECHSE	BUSH	CASQUILLO
17	568463	1	ALBERO	ARBRE	WELLE	SHAFT	ARBOL
18	4968813	3	VITE	VIS	SCHRAUBE	SCREW	TORNILLO
19	5109317	1	SUPPORTO SX	SUPPORT	LAGER	SUPPORT	SOPORTE
20	5109324	1	SUPPORTO DX	SUPPORT	LAGER	SUPPORT	SOPORTE
21	5109313	2	NASTRO DEL FRENO	BANDE DE FREIN	BREMSBAND	BRAKE BAND	CINTA DE FRENO
22	4954205	2	LEVA	LEVIER	HEBEL	LEVER	PALANCA
23	567437	2	BOCCOLA	DOUILLE	BUECHSE	BUSH	CASQUILLO
24	4975196	1	LEVA SX	LEVIER	HEBEL	LEVER	PALANCA
25	13407811	2	INGRASSATORE	GRAISSER	SCHMIERNIPPEL	FITTING	ENGRASADOR

CEB 50

01 02 03

FRIZIONI DI STERZO

*Embrayages de direction
Lenkkupplung*

*Steering Clutches
Embragues de dirección*

50.4/2

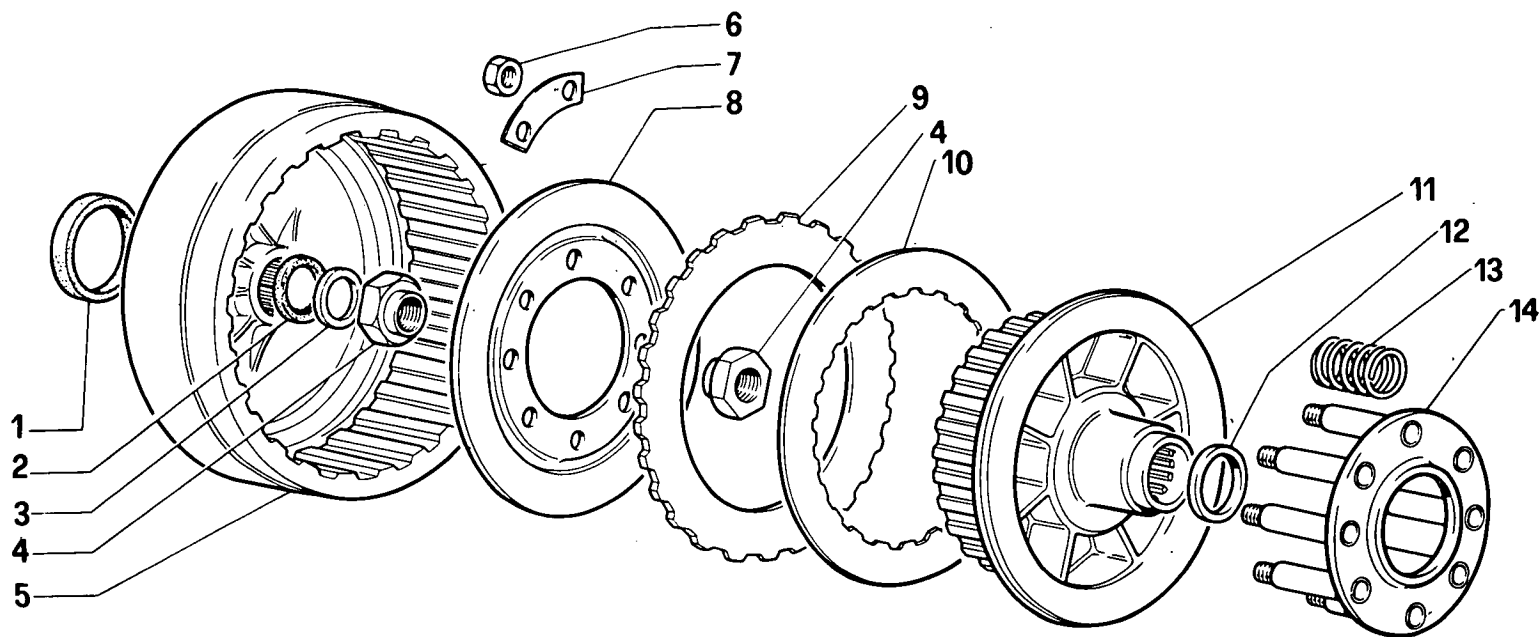

C80/50

FRIZIONI DI STERZO

50.04/02

(09-1981)

FIG	N. ORDINAZIONE	QTA	DENOMINAZIONE	DESIGNATION	BENENNUNG	DESCRIPTION	DENOMINACIONES
1	40000520	2	GUARNIZIONE (03)	GARNITURE	DICHTUNG	GASKET	JUNTA
1	5106081	2	GUARNIZIONE (01-02)	GARNITURE	DICHTUNG	GASKET	JUNTA
2	4954714	2	GUARNIZIONE	GARNITURE	DICHTUNG	GASKET	JUNTA
3	4953367	2	ANELLO DI TENUTA	JOINT D'ETANCHEITE	DICHTRING	SEAL	JUNTA HERMETICA
4	566406	4	DADO	ECROU	MUTTER	NUT	TUERCA
5	566522	2	TAMBURO ESTERNO	TAMBOUR	TROMMEL	DRUM	TAMBOR
6	10791211	16	DADO	ECROU	MUTTER	NUT	TUERCA
7	566480	8	PIASTRINA DI SICUREZZA	PLAQUETTE FREIN	SICHERUNGSBLECH	LOCKPLATE	PLACA DE FRENO
8	572364	2	ANELLO SPINGIDISCO	PLATEAU DE PRESSION	DRUCKPLATTE	PRESSURE PLATE	PLATO DE EMPUJE
9	5109937	12	DISCO CONDOTTO	DISQUE	SCHEIBE	PLATE	DISCO
10	566519	10	DISCO CONDUTTORE	DISQUE	SCHEIBE	PLATE	DISCO
11	572503	2	TAMBURO	TAMBOUR	TROMMEL	DRUM	TAMBOR
12	572504	2	ANELLO SPALLAMENTO	BAGUE A EPAULEMENT	SCHULTERRING	RING	ANILLO CON REBORDE
13	5108833	16	MOLLA	RESSORT	FEDER	SPRING	RESORTE
14	5104725	2	FLANGIA	BRIDE	FLANSCH	FLANGE	BRIDA

C80.50

01 02 03

RUOTA MOTRICE

*Borbotin moteur
Triebrad*

*Drive Sprocket
Rueda motriz*

50.5/1

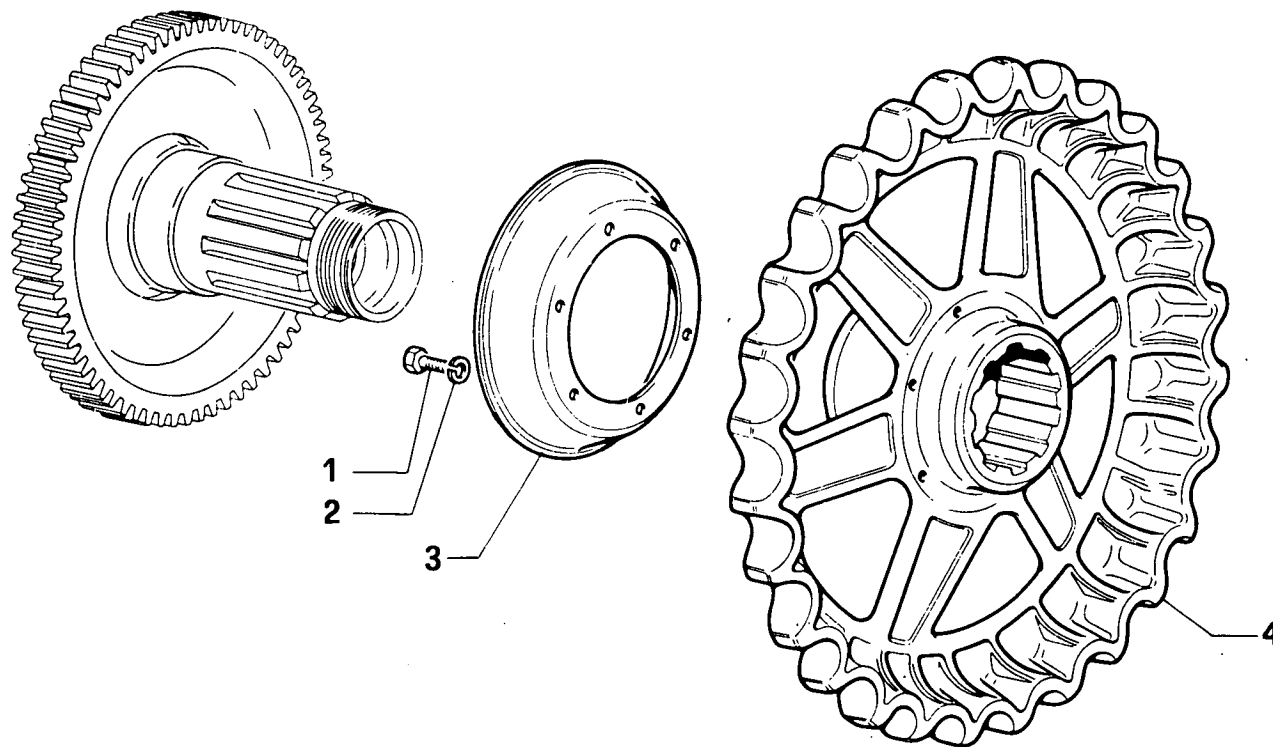

C80/50

RUOTA MOTRICE

50.05/01

(09-1981)

FIG	N. ORDINAZIONE	QTA	DENOMINAZIONE	DESIGNATION	BENENNUNG	DESCRIPTION	DENOMINACIONES
1	16043121	12	VITE	VIS	SCHRAUBE	SCREW	TORNILLO
2	10516671	12	ROSETTA DI SICUREZZA	RONDELLE FREIN	SICHERUNGSRING	LOCKWASHER	ARANDELA DE FRENO
3	539526	2	RIPARO (01-02)	PROTECTION	ABDECKUNG	PROTECTION	DEFENSA
3	539598	2	RIPARO (03)	PROTECTION	ABDECKUNG	PROTECTION	DEFENSA
4	4958366	2	RUOTA MOTRICE (01-02)	BARBOTIN MOTEUR	TREIBRAD	DRIVE SPROCKET	RUEDA MOTRIZ
4	4960130	2	RUOTA MOTRICE (03)	BARBOTIN MOTEUR	TREIBRAD	DRIVE SPROCKET	RUEDA MOTRIZ

CB0.50

01 02 03

TENDICINGOLO

Roue tendeuse
Leitrad

Idler Wheel
Rueda gula

50.5/2

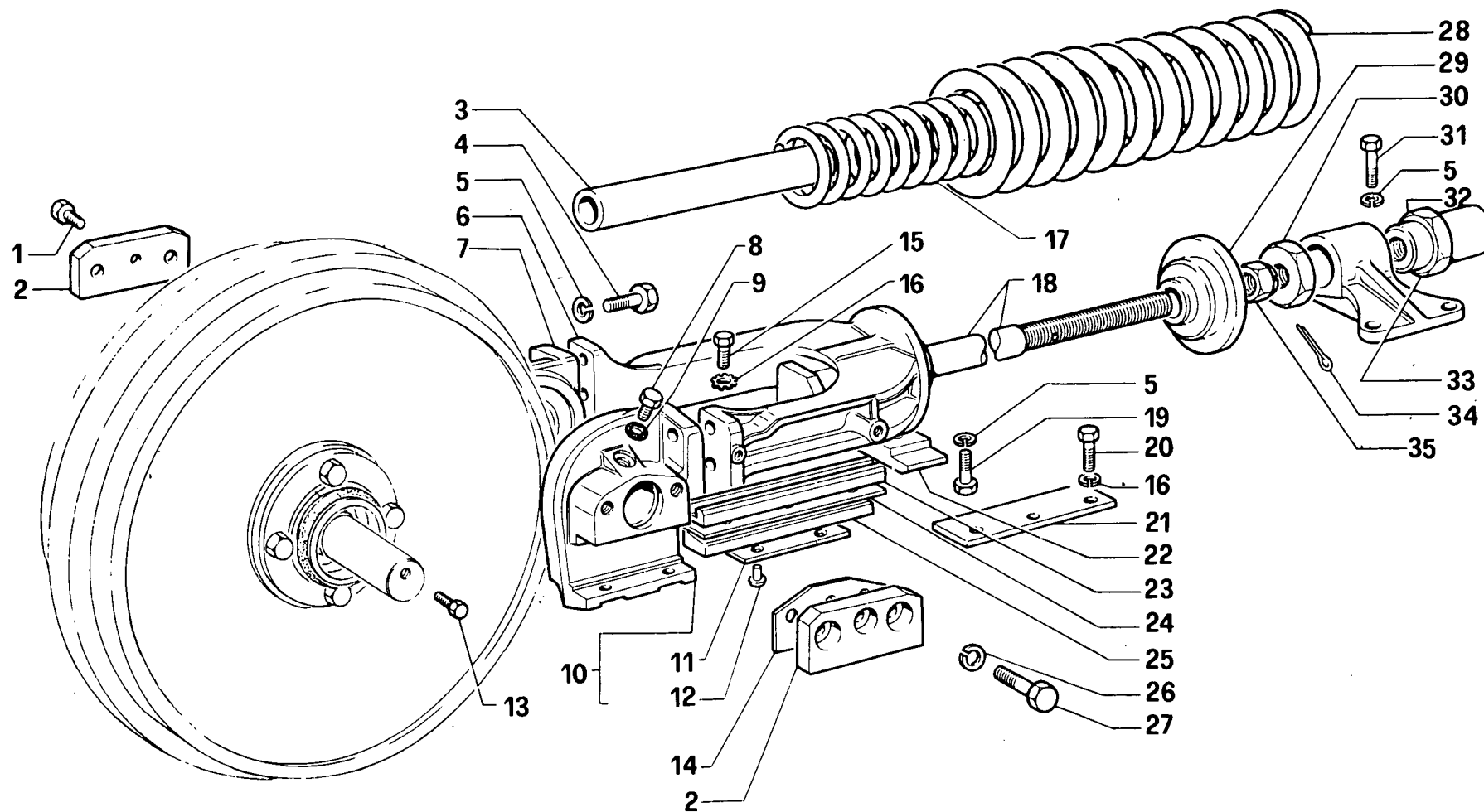

C80/50

TENDICINGOLO

50.05/02

(09-1981)

FIG	N. ORDINAZIONE	QTA	DENOMINAZIONE	DESIGNATION	BENENNUNG	DESCRIPTION	DENOMINACIONES
1	14254121	4	VITE	VIS	SCHRAUBE	SCREW	TORNILLO
2	4968623	2	PIASTRA	PLAQUE	PLATTE	PLATE	PLACA
3	562621	2	DISTANZIALE	ENTRETOISE	ABSTANDSTUECK	SPACER	SEPARADOR
4	15540621	8	VITE	VIS	SCHRAUBE	SCREW	TORNILLO
5	10517071	12	ROSETTA DI SICUREZZA	RONDELLE FREIN	SICHERUNGSRING	LOCKWASHER	ARANDELA DE FRENO
6	4960979	2	SUPPORTO	SUPPORT	LAGER	SUPPORT	SOPORTE
7	4968690	2	ESTREMITA° COMPL.	EXTREMITE	ENDE	END	EXTREMO
8	11903171	2	TAPPO	BOUCHON	STOPFEN	PLUG	TAPON
9	10284460	2	GUARNIZIONE	GARNITURE	DICHTUNG	GASKET	JUNTA
10	4968691	2	ESTREMITA° COMPL.	EXTREMITE	ENDE	END	EXTREMO
11	566638	2	PATTINO	PATIN	GLEITSTEIN	PAD	PATIN
12	10546900	4	RIBATTINO	RIVET	NIET	RIVET	REMACHE
13	14233221	2	VITE	VIS	SCHRAUBE	SCREW	TORNILLO
14	5114353	4	SPESSORE DI REGISTRO	CALE D'EPaisseur	DISTANZSCHEIBE	SHIM	SUPLEMENTO
15	15970721	12	VITE	VIS	SCHRAUBE	SCREW	TORNILLO
16	12605679	12	ROSETTA DI SICUREZZA	RONDELLE FREIN	SICHERUNGSRING	LOCKWASHER	ARANDELA DE FRENO
17	566641	2	MOLLA INTERNA	RESSORT	FEDER	SPRING	RESORTE
18	562619	2	ASTA MOLLA	TIGE	STANGE	ROD	VARILLA
19	15540321	4	VITE	VIS	SCHRAUBE	SCREW	TORNILLO
20	14233221	8	VITE	VIS	SCHRAUBE	SCREW	TORNILLO
21	4960981	4	GUIDA	GUIDE	FUEHRUNG	GUIDE	GUIA
22	4960982	2	SPESSORE DI REGISTRO	CALE D'EPaisseur	DISTANZSCHEIBE	SHIM	SUPLEMENTO
23	566642	4	GUIDA	GUIDE	FUEHRUNG	GUIDE	GUIA
24	566639	8	PIASTRINA	PLAQUETTE	PLAETTCHEN	PLATE	PLACA
25	4971045	4	SPESSORE DI REGISTRO	CALE D'EPaisseur	DISTANZSCHEIBE	SHIM	SUPLEMENTO
26	10517271	8	ROSETTA DI SICUREZZA	RONDELLE FREIN	SICHERUNGSRING	LOCKWASHER	ARANDELA DE FRENO
27	14254121	4	VITE	VIS	SCHRAUBE	SCREW	TORNILLO
28	4998213	2	MOLLA ESTERNA	RESSORT	FEDER	SPRING	RESORTE
29	566627	2	DISCO X MOLLA	DISQUE	SCHEIBE	PLATE	DISCO
30	562620	2	CONTRODADO	CONTRE-ECROU	GEGENMUTTER	COUNTER NUT	CONTRATUERCA
31	11376221	8	VITE	VIS	SCHRAUBE	SCREW	TORNILLO
32	562631	2	DADO COMPL.	ECROU	MUTTER	NUT	TUERCA
33	4960980	2	SUPPORTO	SUPPORT	LAGER	SUPPORT	SOPORTE
34	10796601	2	COPIGLIA	GOUPILLE	SPLINT	SPLIT PIN	PASADOR ABIERTO
35	11693811	2	DADO	ECROU	MUTTER	NUT	TUERCA

C80.50

01 02 03

TENDICINGOLO

Roue tendeuse
Leitrad

Idler Wheel
Rueda guía

50.5/3

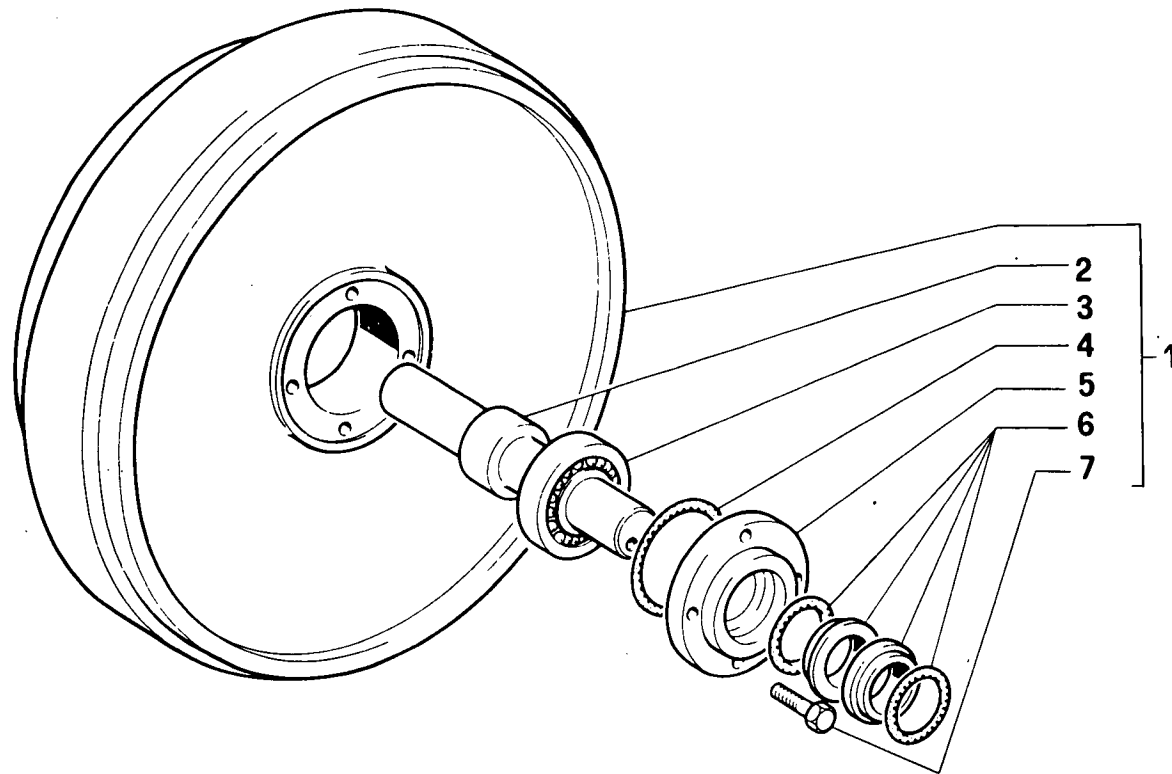

C80/50

TENDICINGOLO

50.05/03

(09-1981)

FIG	N. ORDINAZIONE	QTA	DENOMINAZIONE	DESIGNATION	BENENNUNG	DESCRIPTION	DENOMINACIONES
1	4968695	2	RUOTA TENDICINGOLO	ROUE TENSION CHAIN	KETTENSANNRAD	TENSIONING WHEEL	RUEDA TENSACADENA
2	4973421	1	PERNO RUOTA	AXE	BOLZEN	PIN	EJE
3	24941470	2	CUSCINETTO	ROULEMENT	LAGER	BEARING	RODAMIENTO
4	4973153	2	ANELLO DI TENUTA	JOINT D°ETANCHEITE	DICHTRING	SEAL	JUNTA HERMETICA
5	4973154	2	FLANGIA	BRIDE	FLANSCH	FLANGE	BRIDA
6	4973366	2	ANELLO DI TENUTA	JOINT D°ETANCHEITE	DICHTRING	SEAL	JUNTA HERMETICA
7	14238021	12	VITE	VIS	SCHRAUBE	SCREW	TORNILLO

C80.50

01 02 03

RULLO CARRELLO CINGOLO

*Galet porteur de chenille
Laufrolle der Raupenkette*

*Track Roller
Rodillo de apoyo de la cadena*

50.5/4

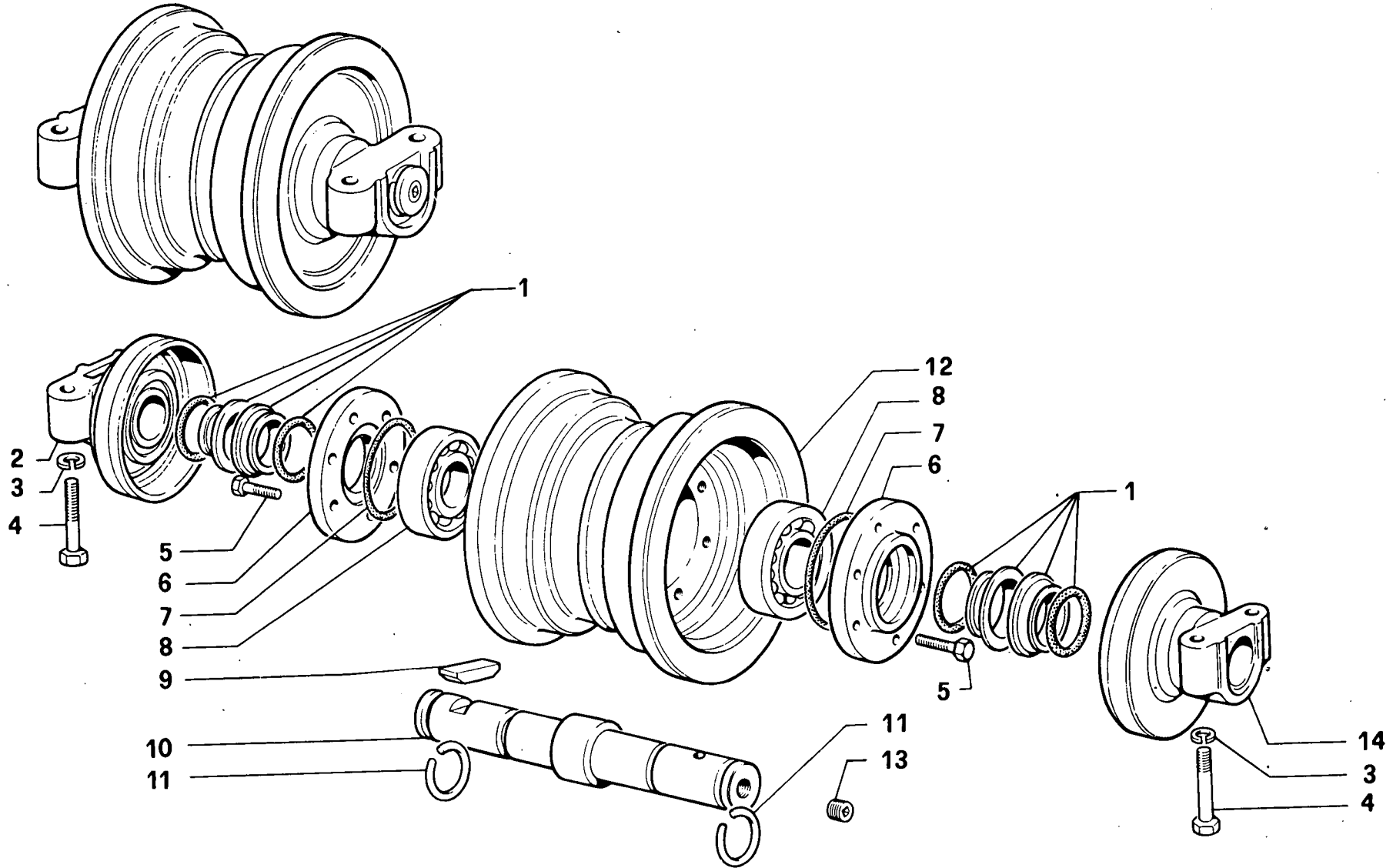

C80/50

RULLO CARRELLO CINGOLO

50.05/04

(09-1981)

FIG	N. ORDINAZIONE	QTA	DENOMINAZIONE	DESIGNATION	BENENNUNG	DESCRIPTION	DENOMINACIONES
	4968573	8	RULLO COMPLETO	GALET	ROLLE	ROLLER	RODILLO
1	4973366	2	ANELLO DI TENUTA	JOINT D°ETANCHEITE	DICHTRING	SEAL	JUNTA HERMETICA
2	4973151	1	SUPPORTO INT.	SUPPORT	LAGER	SUPPORT	SOPORTE
3	10517071	32	ROSETTA DI SICUREZZA	RONDELLE FREIN	SICHERUNGSRING	LOCKWASHER	ARANDELA DE FRENO
4	15540630	32	VITE	VIS	SCHRAUBE	SCREW	TORNILLO
5	14238021	12	VITE	VIS	SCHRAUBE	SCREW	TORNILLO
6	4973154	2	FLANGIA	BRIDE	FLANSCH	FLANGE	BRIDA
7	4973153	2	ANELLO DI TENUTA	JOINT D°ETANCHEITE	DICHTRING	SEAL	JUNTA HERMETICA
8	24941470	2	CUSCINETTO	ROULEMENT	LAGER	BEARING	RODAMIENTO
9	566614	1	LINGUETTA	LINGUET	SCHEIBENFEDER	KEY	CHAVETA
10	4973157	1	ALBERO RULLO	ARBRE	WELLE	SHAFT	ARBOL
11	4973156	2	ANELLO DI SICUREZZA	ARRETOIR	SICHERUNGSRING	LOCKRING	ANILLO DE FRENO
12	4973152	1	RULLO	GALET	ROLLE	ROLLER	RODILLO
13	4973150	1	TAPPO	BOUCHON	STOPFEN	PLUG	TAPON
14	4973149	1	SUPPORTO ESTERNO	SUPPORT	LAGER	SUPPORT	SOPORTE

C80.50

01 02 03

CINGOLO

Chenille
Raupenkette

Track
Cadena

50.6/1

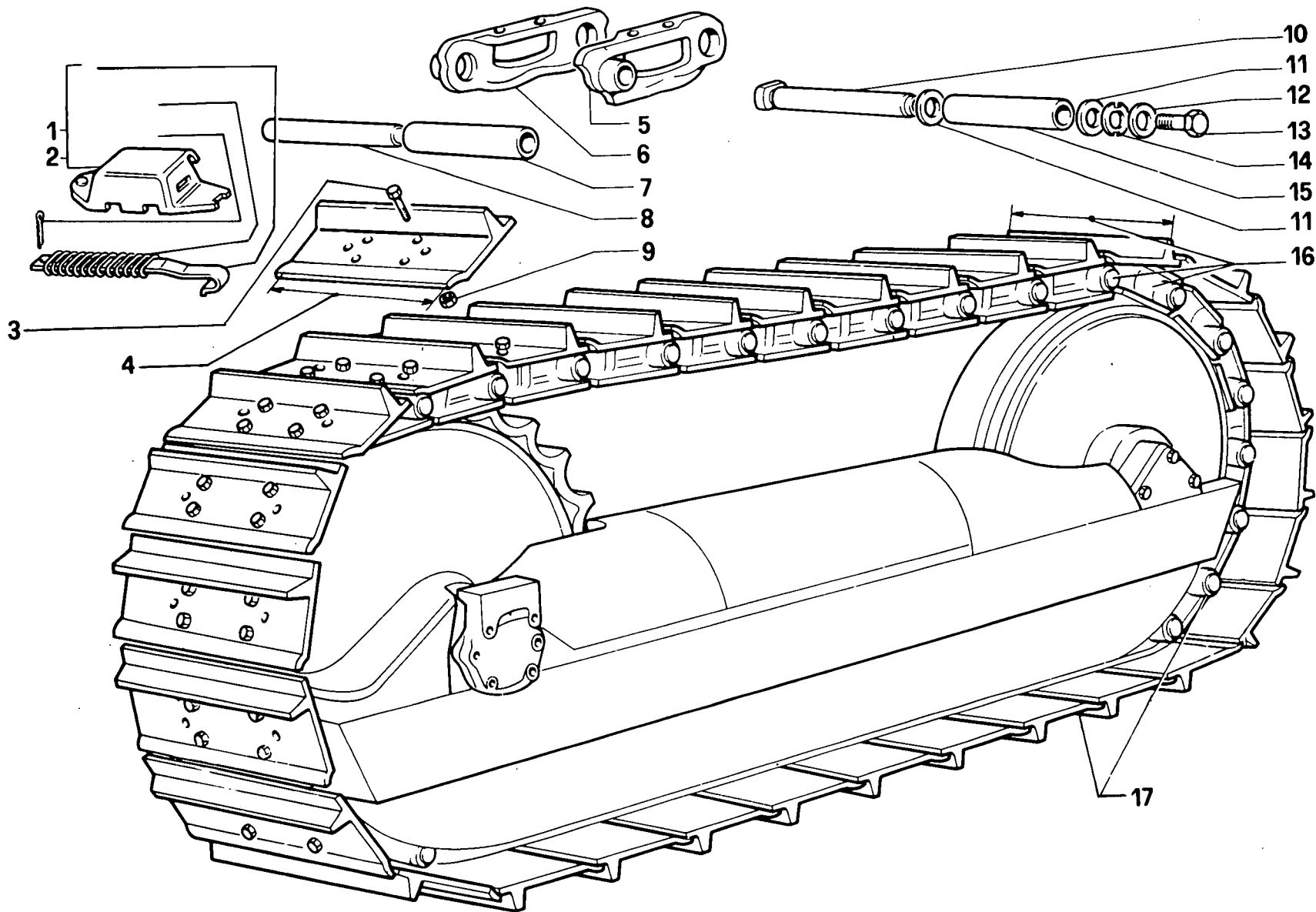

C80/50

CINGOLO

50.06/01

(09-1981)

FIG	N. ORDINAZIONE	QTA	DENOMINAZIONE	DESIGNATION	BENENNUNG	DESCRIPTION	DENOMINACIONES
1	571053	17	SOPRASUOLA DX 03(200)	PATIN DE ROUTE	STRASSENSCHUN	STREET PLATE	PATIN DE CARRETERA
1	571061	17	SOPRASUOLA DX 01-03(250)	PATIN DE ROUTE	STRASSENSCHUN	STREET PLATE	PATIN DE CARRETERA
1	4994520	17	SOPRASUOLA DX 01-03(300)	PATIN DE ROUTE	STRASSENSCHUN	STREET PLATE	PATIN DE CARRETERA
1	4959963	17	SOPRASUOLA DX 02(300)	PATIN DE ROUTE	STRASSENSCHUN	STREET PLATE	PATIN DE CARRETERA
2	571054	17	SOPRASUOLA SX 03(200)	PATIN DE ROUTE	STRASSENSCHUN	STREET PLATE	PATIN DE CARRETERA
2	571062	17	SOPRASUOLA SX 01-03(250)	PATIN DE ROUTE	STRASSENSCHUN	STREET PLATE	PATIN DE CARRETERA
2	4959998	17	SOPRASUOLA SX 02(300)	PATIN DE ROUTE	STRASSENSCHUN	STREET PLATE	PATIN DE CARRETERA
2	4994521	17	SOPRASUOLA SX 01-03(300)	PATIN DE ROUTE	STRASSENSCHUN	STREET PLATE	PATIN DE CARRETERA
3	557155	272	VITE	VIS	SCHRAUBE	SCREW	TORNILLO
4	557481	68	SUOLA CINGOLO MM 200 (03)	PATIN	BODENPLATTE	SHOE	ZAPATA
4	558435	68	SUOLA CINGOLO MM 250 (01-03)	PATIN	BODENPLATTE	SHOE	ZAPATA
4	4960799	68	SUOLA CINGOLO MM 300 (02)	PATIN	BODENPLATTE	SHOE	ZAPATA
4	4990252	34	SUOLA CINGOLO DX 300 (01-03)	PATIN	BODENPLATTE	SHOE	ZAPATA
4	4990251	34	SUOLA CINGOLO SX 300 (01-03)	PATIN	BODENPLATTE	SHOE	ZAPATA
5	557078	68	MAGLIA DEL CINGOLO DX	MAILLON	KETTNLASCHE	LINK	ESLABON
6	557079	68	MAGLIA DEL CINGOLO SX	MAILLON	KETTNLASCHE	LINK	ESLABON
7	5011951	66	BOCCOLA	DOUILLE	BUECHSE	BUSH	CASQUILLO
8	5011871	66	PERNO	AXE	BOLZEN	PIN	EJE
9	557156	272	DADO	ECROU	MUTTER	NUT	TUERCA
10	557081	2	PERNO UNIONE	AXE	BOLZEN	PIN	EJE
11	557084	4	ROSETTA PIANA	RONDELLE	SCHEIBE	WASHER	ARANDELA
12	580968	2	ROSETTA PIANA	RONDELLE	SCHEIBE	WASHER	ARANDELA
13	580970	2	VITE	VIS	SCHRAUBE	SCREW	TORNILLO
14	580969	2	ROSETTA DI SICUREZZA	RONDELLE FREIN	SICHERUNGSRING	LOCKWASHER	ARANDELA DE FRENO
15	5011952	2	BOCCOLA	DOUILLE	BUECHSE	BUSH	CASQUILLO
16	4960993	2	CATENA COMPLETA	CHAINE	KETTE	CHIAN	CADENA

CEO.50

01 02 03

CINGOLO

Chenille
Raupenkette

Track
Cadena

50.6/1

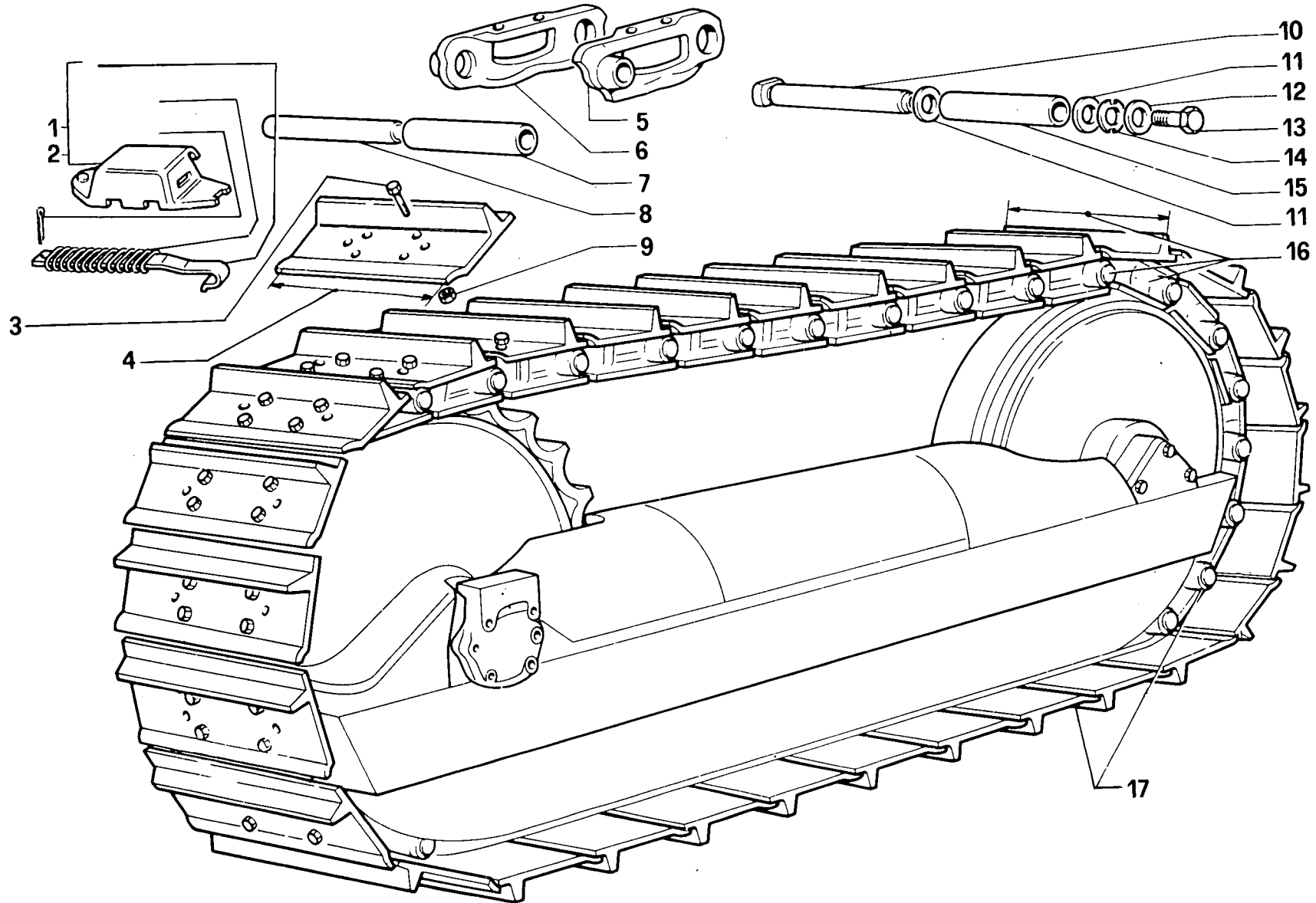

C80/50

CINGOLO

50.06/01

(09-1981)

FIG	N. ORDINAZIONE	QTA	DENOMINAZIONE	DESIGNATION	BENENNUNG	DESCRIPTION	DENOMINACIONES
17	4969426	2	CATENARIA COMPLETA (03)	CHAINE ASSEMBLEE	RAUPENKETTE	TRACK ASSY.	CADENA
17	4960991	2	CATENARIA COMPLETA (01-03)250	CHAINE ASSEMBLEE	RAUPENKETTE	TRACK ASSY.	CADENA
17	4969835	2	CATENARIA COMPLETA (02)300	CHAINE ASSEMBLEE	RAUPENKETTE	TRACK ASSY.	CADENA

COMANDO DISINNESTO FRIZIONI DI STERZO

Commande des embrayages de direction
Ausrückvorrichtung der Lenkkupplung

Steering Clutches Release Control
Mando de embragues de dirección

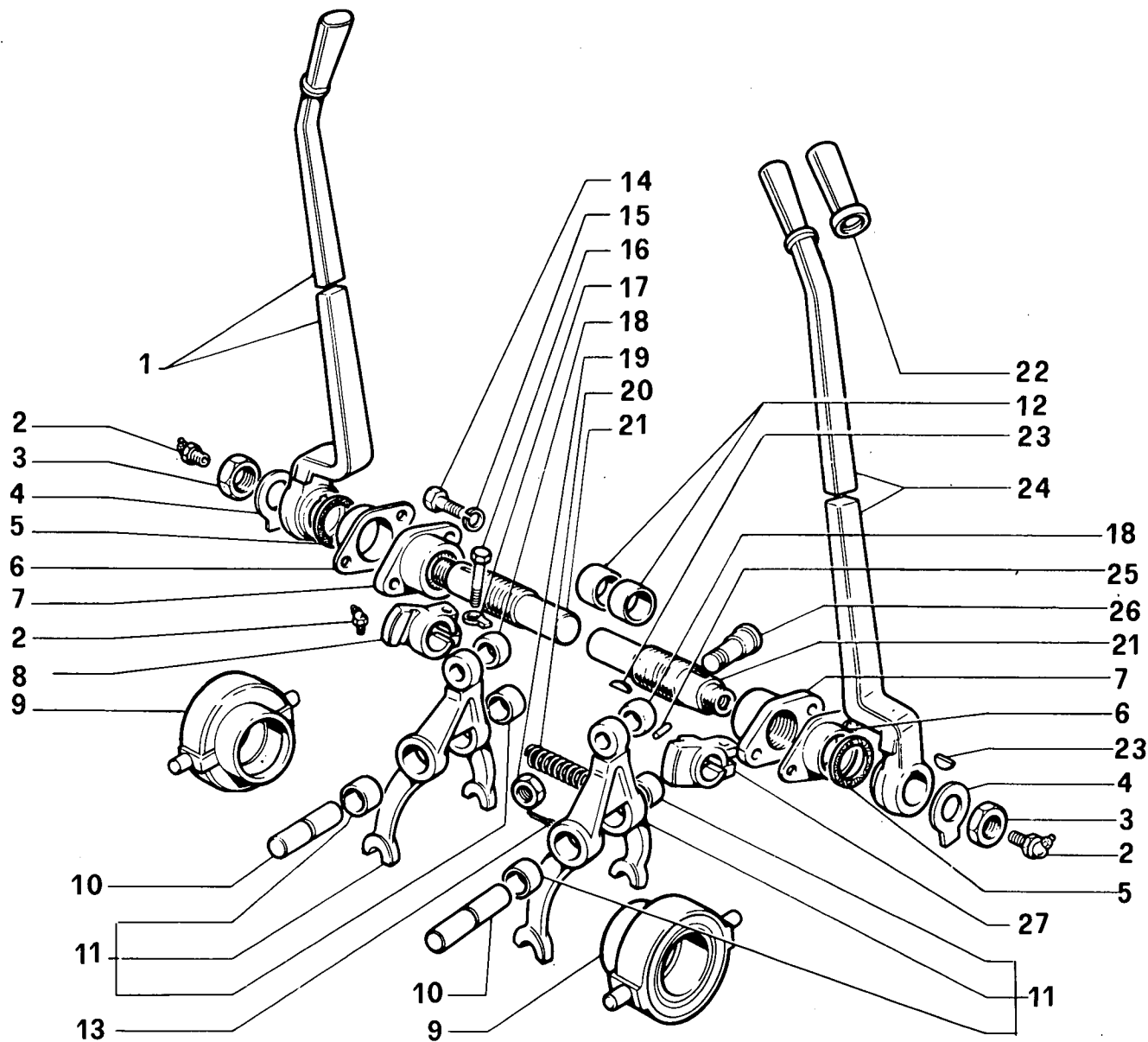

C80/50

COMANDO DISINNESTO FRIZIONI DI STERZO

60.01/01

(09-1981)

FIG	N. ORDINAZIONE	QTA	DENOMINAZIONE	DESIGNATION	BENENNUNG	DESCRIPTION	DENOMINACIONES
1	5117596	1	LEVA DX	LEVIER	HEBEL	LEVER	PALANCA
2	13408411	4	INGRASSATORE	GRAISSER	SCHMIERNIPPEL	FITTING	ENGRASADOR
3	10726711	2	DADO	ECROU	MUTTER	NUT	TUERCA
4	10054110	2	ROSETTA DI SICUREZZA	RONDELLE FREIN	SICHERUNGSRING	LOCKWASHER	ARANDELA DE FRENO
5	4954714	2	GUARNIZIONE	GARNITURE	DICHTUNG	GASKET	JUNTA
6	569412	2	PROTEZIONE	PROTECTION	ABDECKUNG	SHIELD	DEFENSA
7	5107048	2	SUPPORTO	SUPPORT	LAGER	SUPPORT	SOPORTE
8	566478	1	LEVA DX	LEVIER	HEBEL	LEVER	PALANCA
9	5107403	2	MANICOTTO INNESTO	MANCHON D'EMBRAYAGE	EINRUECKMUFFE	ENGAGING SLEEVE	MANGUITO CONEXION
10	562676	2	PERNO	AXE	BOLZEN	PIN	EJE
11	566675	2	LEVA	LEVIER	HEBEL	LEVER	PALANCA
12	562678	4	BOCCOLA	DOUILLE	BUECHSE	BUSH	CASQUILLO
13	10797001	2	COPIGLIA	GOUPILLE	SPLINT	SPLIT PIN	PASADOR ABIERTO
14	10923321	4	VITE	VIS	SCHRAUBE	SCREW	TORNILLO
15	10516871	4	ROSETTA DI SICUREZZA	RONDELLE FREIN	SICHERUNGSRING	LOCKWASHER	ARANDELA DE FRENO
16	11307021	2	VITE	VIS	SCHRAUBE	SCREW	TORNILLO
17	562659	2	PIASTRINA DI SICUREZZA	PLAQUETTE FREIN	SICHERUNGSBLECH	LOCKPLATE	PLACA DE FRENO
18	547546	2	RULLO	GALET	ROLLE	ROLLER	RODILLO
19	10793511	2	DADO	ECROU	MUTTER	NUT	TUERCA
20	571604	2	MOLLA	RESSORT	FEDER	SPRING	RESORTE
21	5107047	2	ALBERO DI RINVIO	ARBRE DE RENVOI	ZWISCHEN WELLE	IDLE SHAFT	ARBOL DE REENVIO
22	578159	2	CUFFIA	CAPUCHON	MANSCHETTE	BOOT	CAPUCHON
23	10206020	4	LINGUETTA	LINGUET	SCHEIBENFEDER	KEY	CHAVETA
24	5117598	1	LEVA SX	LEVIER	HEBEL	LEVER	PALANCA
25	28044380	44	RULLINO	AIGUILLE	NADEL	NEEDLE	AGUJA
26	547545	2	PERNO	AXE	BOLZEN	PIN	EJE
27	566479	1	LEVA SX	LEVIER	HEBEL	LEVER	PALANCA

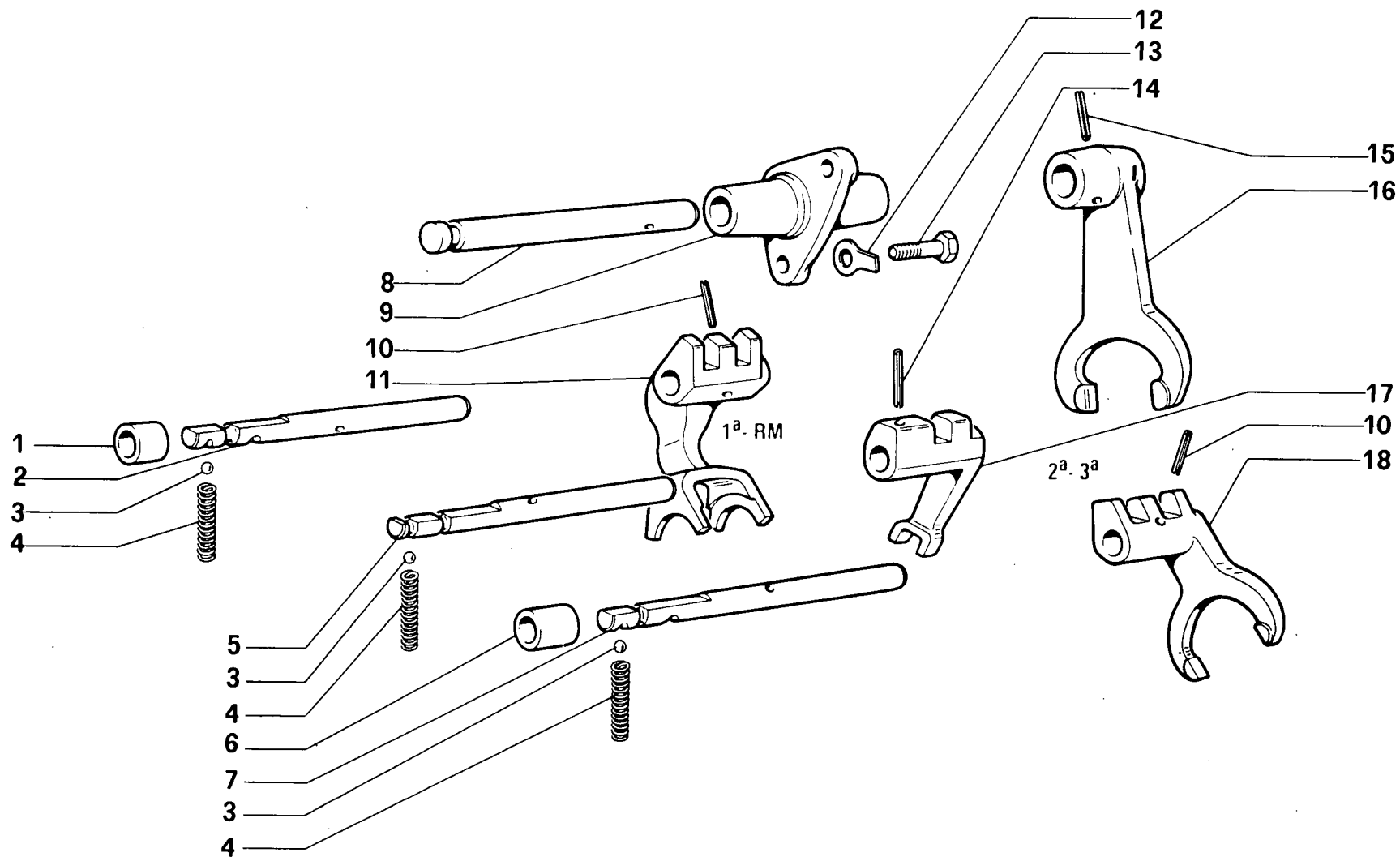

C80/50

COMANDO CAMBIO

60.04/01

(09-1981)

FIG	N. ORDINAZIONE	QTA	DENOMINAZIONE	DESIGNATION	BENENNUNG	DESCRIPTION	DENOMINACIONES
1	563453	1	DISTANZIALE	ENTRETOISE	ABSTANDSTUECK	SPACER	SEPARADOR
2	4971673	1	ASTA DI COMANDO I - RM	BARRE EMBRAYAGE	SCHALTSTANGE	SHIFT ROD	BARRA CAMBIO
3	20063390	5	SFERA	BILLE	KUGEL	BALL	BOLA
4	583582	3	MOLLA	RESSORT	FEDER	SPRING	RESORTE
5	4971773	1	ASTA NASELLO	TIGE	STANGE	ROD	VARILLA
6	563454	1	DISTANZIALE	ENTRETOISE	ABSTANDSTUECK	SPACER	SEPARADOR
7	4971772	1	ASTA DI COMANDO II - III	BARRE EMBRAYAGE	SCHALTSTANGE	SHIFT ROD	BARRA CAMBIO
8	563438	1	ASTA FORCELLA COM. RIDUTT.	TIGE	STANGE	ROD	VARILLA
9	584785	1	SUPPORTO	SUPPORT	LAGER	SUPPORT	SOPORTE
10	14166170	2	SPINA	GOUPILLE	STIFT	PIN	PASADOR
11	579004	1	FORCELLA CAMBIO I - RM	FOURCHETTE CDE	SCHALTGABEL	SHIFT FORK	HORQUILLA CAMBIO
12	10053610	2	PIASTRINA DI SICUREZZA	PLAQUETTE FREIN	SICHERUNGSBLECH	LOCKPLATE	PLACA DE FRENO
13	15970721	2	VITE	VIS	SCHRAUBE	SCREW	TORNILLO
14	14166570	1	SPINA	GOUPILLE	STIFT	PIN	PASADOR
15	14166370	1	SPINA	GOUPILLE	STIFT	PIN	PASADOR
16	567871	1	FORCELLA COM. RIDUTTORE	FOURCHE	GABEL	FORK	HORQUILLA
17	593351	1	NASELLO	TENON	ANSCHLAG	DOG	TOPE
18	565548	1	FORCELLA CAMBIO II - III	FOURCHETTE CDE	SCHALTGABEL	SHIFT FORK	HORQUILLA CAMBIO

COMANDO CAMBIO

Commande de boîte de vitesse
Getriebeschaltung

Gearshiftcontrol
Varilla del cambio de velocidades

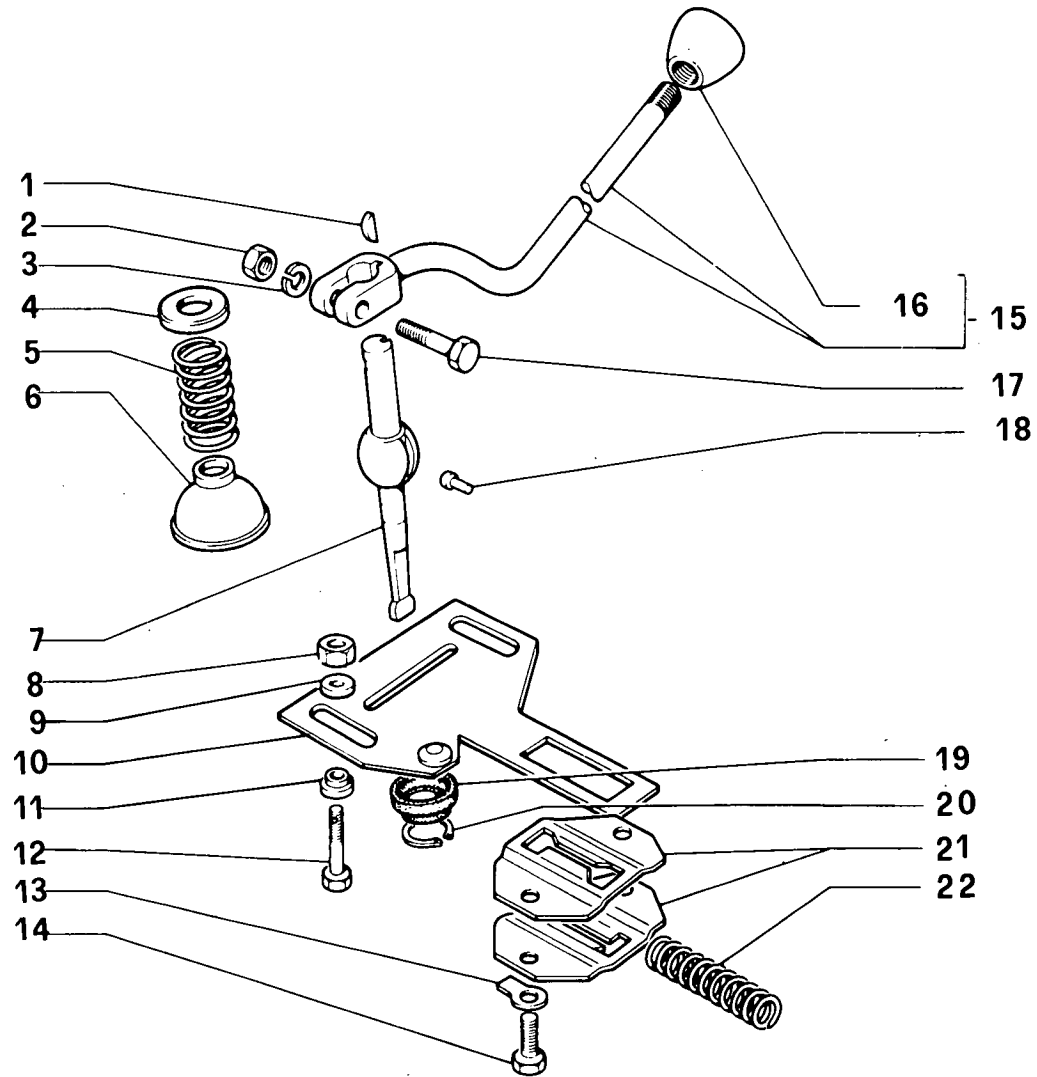

C80/50

COMANDO CAMBIO

60.04/02

(09-1981)

FIG	N. ORDINAZIONE	QTA	DENOMINAZIONE	DESIGNATION	BENENNUNG	DESCRIPTION	DENOMINACIONES
1	10205810	1	LINGUETTA	LINGUET	SCHEIBENFEDER	KEY	CHAVETA
2	16100811	1	DADO	ECROU	MUTTER	NUT	TUERCA
3	10516671	1	ROSETTA DI SICUREZZA	RONDELLE FREIN	SICHERUNGSRING	LOCKWASHER	ARANDELA DE FRENO
4	592760	1	SCODELLINO	CUVETTE	TELLERSCHEIBE	CUP	PLATILLO
5	592758	1	MOLLA	RESSORT	FEDER	SPRING	RESORTE
6	592759	1	COPERCHIO	COUVERCLE	DECKEL	COVER	TAPA
7	4952624	1	LEVA	LEVIER	HEBEL	LEVER	PALANCA
8	14048222	2	DADO	ECROU	MUTTER	NUT	TUERCA
9	10519601	2	ROSETTA DI SICUREZZA	RONDELLE FREIN	SICHERUNGSRING	LOCKWASHER	ARANDELA DE FRENO
10	4976938	1	SETTORE COMPL.	TIRANT	SPREIZTANGE	STRUT	BIELA
11	565750	2	DISTANZIALE	ENTRETOISE	ABSTANDSTUECK	SPACER	SEPARADOR
12	16043821	2	VITE	VIS	SCHRAUBE	SCREW	TORNILLO
13	10053510	2	ROSETTA DI SICUREZZA	RONDELLE FREIN	SICHERUNGSRING	LOCKWASHER	ARANDELA DE FRENO
14	16043421	2	VITE	VIS	SCHRAUBE	SCREW	TORNILLO
15	4961252	1	LEVA CAMBIO	LEVIER	HEBEL	LEVER	PALANCA
16	4960851	1	IMPUGNATURA	POIGNEE	GRIF	KNOB	BOTON
17	16044021	1	VITE	VIS	SCHRAUBE	SCREW	TORNILLO
18	536435	2	NOTTOLINO	CLIQUET	KLINKE	PAWL	SEGURO
19	4984223	1	GUARNIZIONE	GARNITURE	DICHTUNG	GASKET	JUNTA
20	11059976	1	ANELLO DI SICUREZZA	ARRETOIR	SICHERUNGSRING	LOCKRING	ANILLO DE FRENO
21	568781	1	STAFFA	ETRIER	HALTER	BRACKET	SOPORTE
22	568779	1	MOLLA	RESSORT	FEDER	SPRING	RESORTE

COMANDO DISINNESTO FRIZIONE

Commande de débrayage
Kupplungsbetätigung

Clutch Release Control
Sistema de embrague

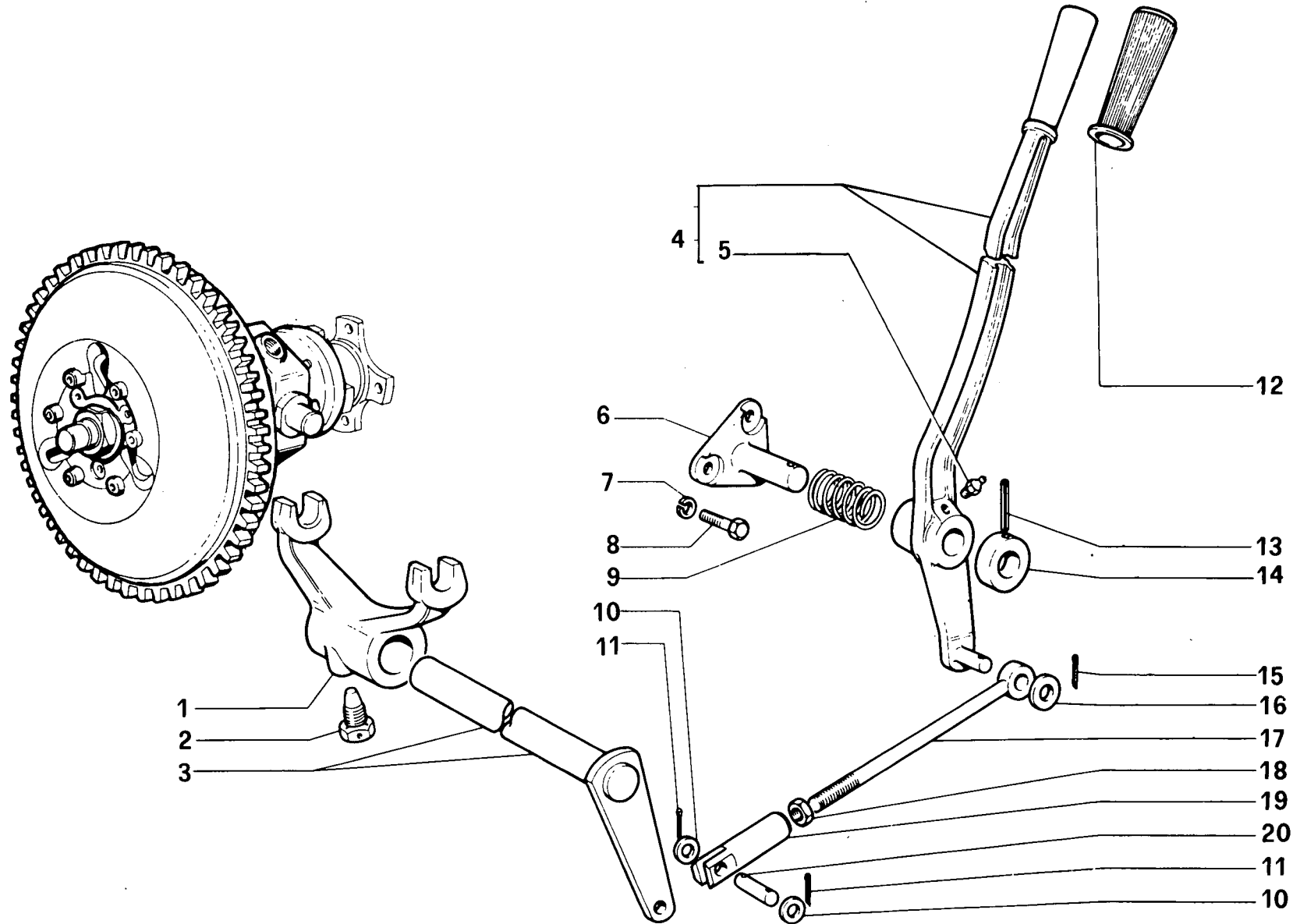

C80/50

COMANDO DISINNESTO FRIZIONE

60.05/01

(09-1981)

FIG	N. ORDINAZIONE	QTA	DENOMINAZIONE	DESIGNATION	BENENNUNG	DESCRIPTION	DENOMINACIONES
1	599732	1	FORCELLA DISINN. FRIZIONE	FOURCHETTE D'EMBR.	KUPPLUNGSGABEL	CLUTCH FORK	HORQUILLA EMBRAGUE
2	4968813	1	VITE	VIS	SCHRAUBE	SCREW	TORNILLO
3	588159	1	ALBERO	ARBRE	WELLE	SHAFT	ARBOL
4	5117594	1	LEVA COMPL.	LEVIER	HEBEL	LEVER	PALANCA
5	13407211	1	INGRASSATORE	GRAISSER	SCHMIERNIPPEL	FITTING	ENGRASADOR
6	583319	1	PERNO	AXE	BOLZEN	PIN	EJE
7	10517071	2	ROSETTA DI SICUREZZA	RONDELLE FREIN	SICHERUNGSRING	LOCKWASHER	ARANDELA DE FRENO
8	10944921	2	VITE	VIS	SCHRAUBE	SCREW	TORNILLO
9	538595	1	MOLLA	RESSORT	FEDER	SPRING	RESORTE
10	12642701	2	ROSETTA DI SICUREZZA	RONDELLE FREIN	SICHERUNGSRING	LOCKWASHER	ARANDELA DE FRENO
11	10734201	2	COPIGLIA	GOUPILLE	SPLINT	SPLIT PIN	PASADOR ABIERTO
12	578159	1	CUFFIA	CAPUCHON	MANSCHETTE	BOOT	CAPUCHON
13	14166770	1	SPINA ELASTICA	FICHE A RESSORT	FEDERSTECKER	CLIP PIN	CLAVIJA RESORTE
14	568457	1	ANELLO	BAGUE	RING	RING	ANILLO
15	10733601	1	COPIGLIA	GOUPILLE	SPLINT	SPLIT PIN	PASADOR ABIERTO
16	10520001	1	ROSETTA PIANA	RONDELLE	SCHEIBE	WASHER	ARANDELA
17	571149	1	TIRANTE	TIRANT	STANGE	ROD	VARILLA
18	10791011	1	DADO	ECROU	MUTTER	NUT	TUERCA
19	565916	1	FORCELLINO	FOURCHE	GABEL	FORK	HORQUILLA
20	4969393	1	PERNO	AXE	BOLZEN	PIN	EJE

CEB.50

01 02 03

COMANDO A MANO FRENI

Commande de freins à main
Handbremsbetätigung

Brake Hand Control
Freno de mano

60.6/1

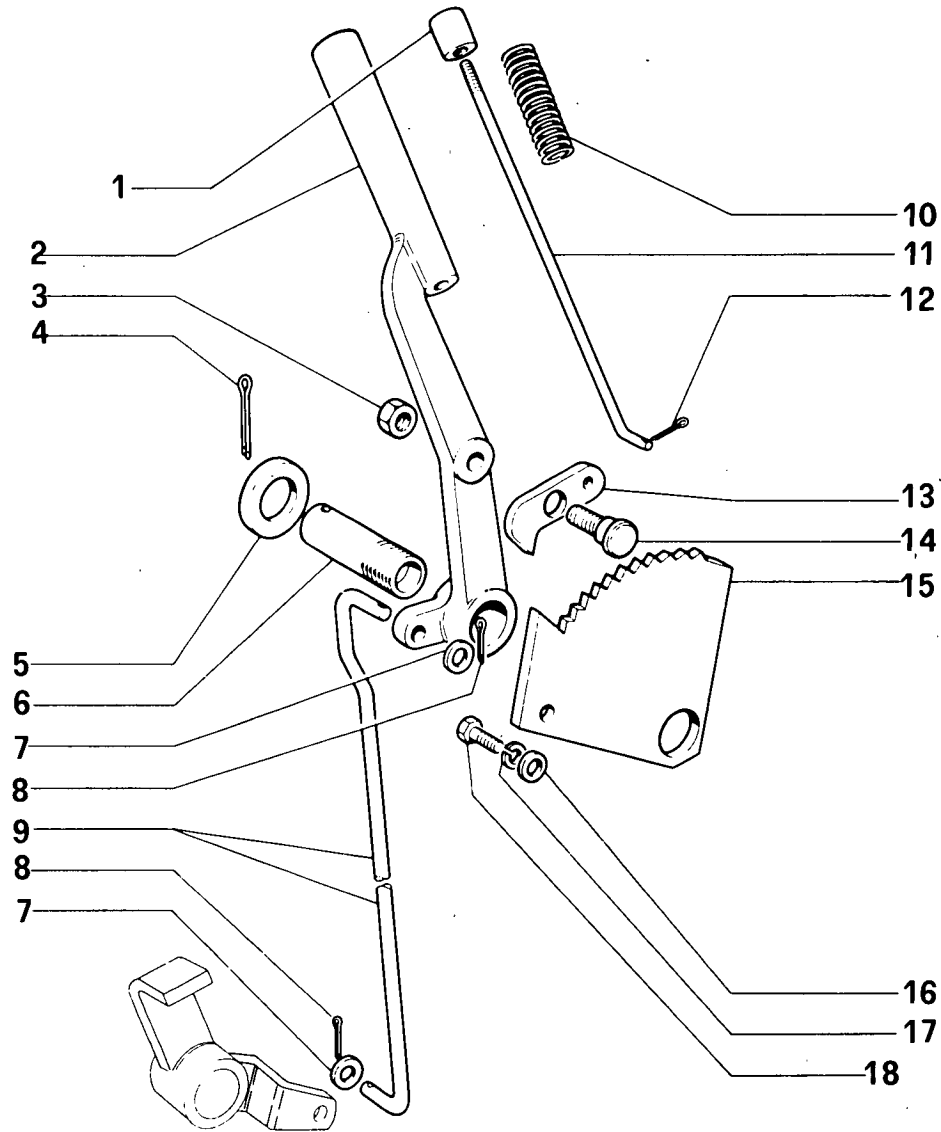

C80/50

COMANDO A MANO FRENI

60.06/01

(09-1981)

FIG	N. ORDINAZIONE	QTA	DENOMINAZIONE	DESIGNATION	BENENNUNG	DESCRIPTION	DENOMINACIONES
1	4953875	1	PULSANTE	BOUTON	DRUCKKNOFF	BUTTON	PULSADOR
2	570774	1	LEVA FRENO A MANO	LEVIER DE FR. MAIN	HANDBREMSCHABEL	HAND BRAKE LEVER	PALANCA FRENO MANO
3	16102311	1	DADO	ECROU	MUTTER	NUT	TUERCA
4	10797401	1	COPIGLIA	GOUPILLE	SPLINT	SPLIT PIN	PASADOR ABIERTO
5	10520501	1	ROSETTA PIANA	RONDELLE	SCHEIBE	WASHER	ARANDELA
6	572696	1	PERNO	AXE	BOLZEN	PIN	EJE
7	12638601	2	ROSETTA PIANA	RONDELLE	SCHEIBE	WASHER	ARANDELA
8	10796401	2	COPIGLIA	GOUPILLE	SPLINT	SPLIT PIN	PASADOR ABIERTO
9	4970305	1	TIRANTE	TIRANT	STANGE	ROD	VARILLA
10	15480	1	MOLLA	RESSORT	FEDER	SPRING	RESORTE
11	570775	1	PUNTONE	ETAI	STREBE	STRUT	TORNAPUNTA
12	10734201	1	COPIGLIA	GOUPILLE	SPLINT	SPLIT PIN	PASADOR ABIERTO
13	554215	1	NOTTOLINO	CLIQUET	KLINKE	PAWL	SEGURO
14	563126	1	PERNO	AXE	BOLZEN	PIN	EJE
15	568420	1	SETTORE DENTATO	SECTEUR DENTE	ZAHNBOGEN	SECTOR	RUEDA DENTADA
16	12646801	1	ROSETTA PIANA	RONDELLE	SCHEIBE	WASHER	ARANDELA
17	10516871	1	ROSETTA DI SICUREZZA	RONDELLE FREIN	SICHERUNGSRING	LOCKWASHER	ARANDELA DE FRENO
18	15970521	1	VITE	VIS	SCHRAUBE	SCREW	TORNILLO

CEB.50

01 02 03

COMANDI ACCELERATORE (POMPA CAV)

Commandes d'accélérateur
Gasregulierung

Accelerator Control Linkage
Mandos del acelerador

60.7/1

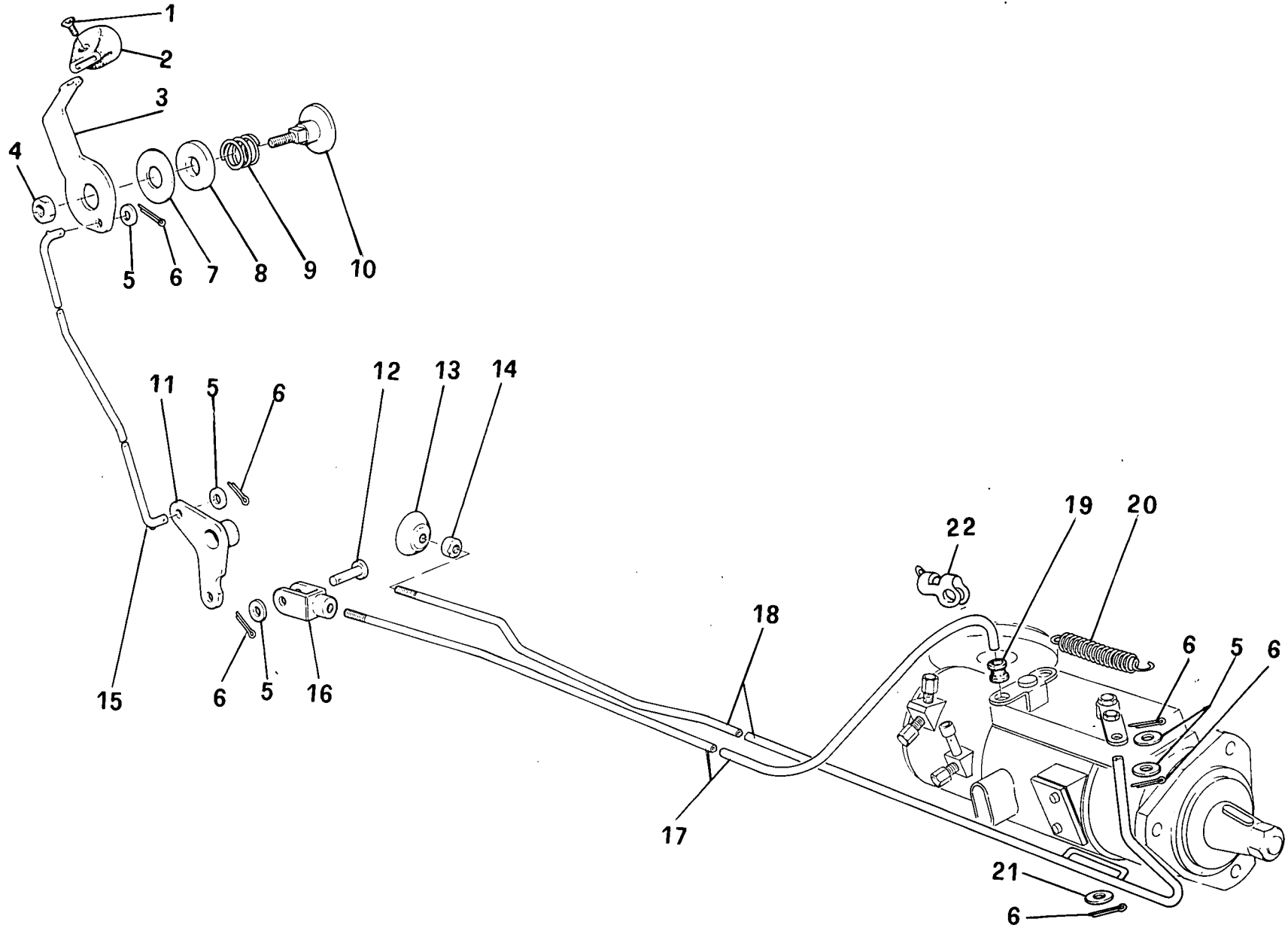

C80/50

COMANDI ACCELERATORE

60.07/01

(09-1981)

FIG	N. ORDINAZIONE	QTA	DENOMINAZIONE	DESIGNATION	BENENNUNG	DESCRIPTION	DENOMINACIONES
1	15919401	1	VITE	VIS	SCHRAUBE	SCREW	TORNILLO
2	44901717	1	POMELLO	BOUTON	KNEBELGRIFF	KNOB	BOTON
3	5119573	1	LEVA	LEVIER	HEBEL	LEVER	PALANCA
4	16104111	1	DADO	ECROU	MUTTER	NUT	TUERCA
5	10519401	3	ROSETTA DI SICUREZZA	RONDELLE FREIN	SICHERUNGSRING	LOCKWASHER	ARANDELA DE FRENO
6	10734601	4	COPIGLIA	GOUPILLE	SPLINT	SPLIT PIN	PASADOR ABIERTO
7	561887	1	DISCO DI FRIZIONE	DISQUE DE FRICTION	REIBSCHEIBE	FRICTION DISC	PLATO FRICCION
8	551061	1	SCODELLINO	CUVETTE	TELLERSCHEIBE	CUP	PLATILLO
9	541053	1	MOLLA	RESSORT	FEDER	SPRING	RESORTE
10	4999850	1	PERNO	AXE	BOLZEN	PIN	EJE
11	4951711	1	LEVA	LEVIER	HEBEL	LEVER	PALANCA
12	10033211	1	PERNO	AXE	BOLZEN	PIN	EJE
13	4951360	1	POMELLO	BOUTON	KNEBELGRIFF	KNOB	BOTON
14	10788811	1	DADO	ECROU	MUTTER	NUT	TUERCA
15	44901512	1	TIRANTE	TIRANT	STANGE	ROD	VARILLA
16	10248011	1	FORCELLINO	FOURCHE	GABEL	FORK	HORQUILLA
17	4951719	1	TIRANTE ACCELERATORE	TIRANT	STANGE	ROD	VARILLA
18	4951721	1	TIRANTE STOP MOTORE	TIRANT	STANGE	ROD	VARILLA
19	4954251	1	BOCCOLA	DOUILLE	BUECHSE	BUSH	CASQUILLO
20	4954645	1	MOLLA	RESSORT	FEDER	SPRING	RESORTE
21	10734201	1	COPIGLIA	GOUPILLE	SPLINT	SPLIT PIN	PASADOR ABIERTO
22	814838	1	FERMAGLIO	AGRAFE	KLEMMSTUECK	CLIP	SUJETADOR

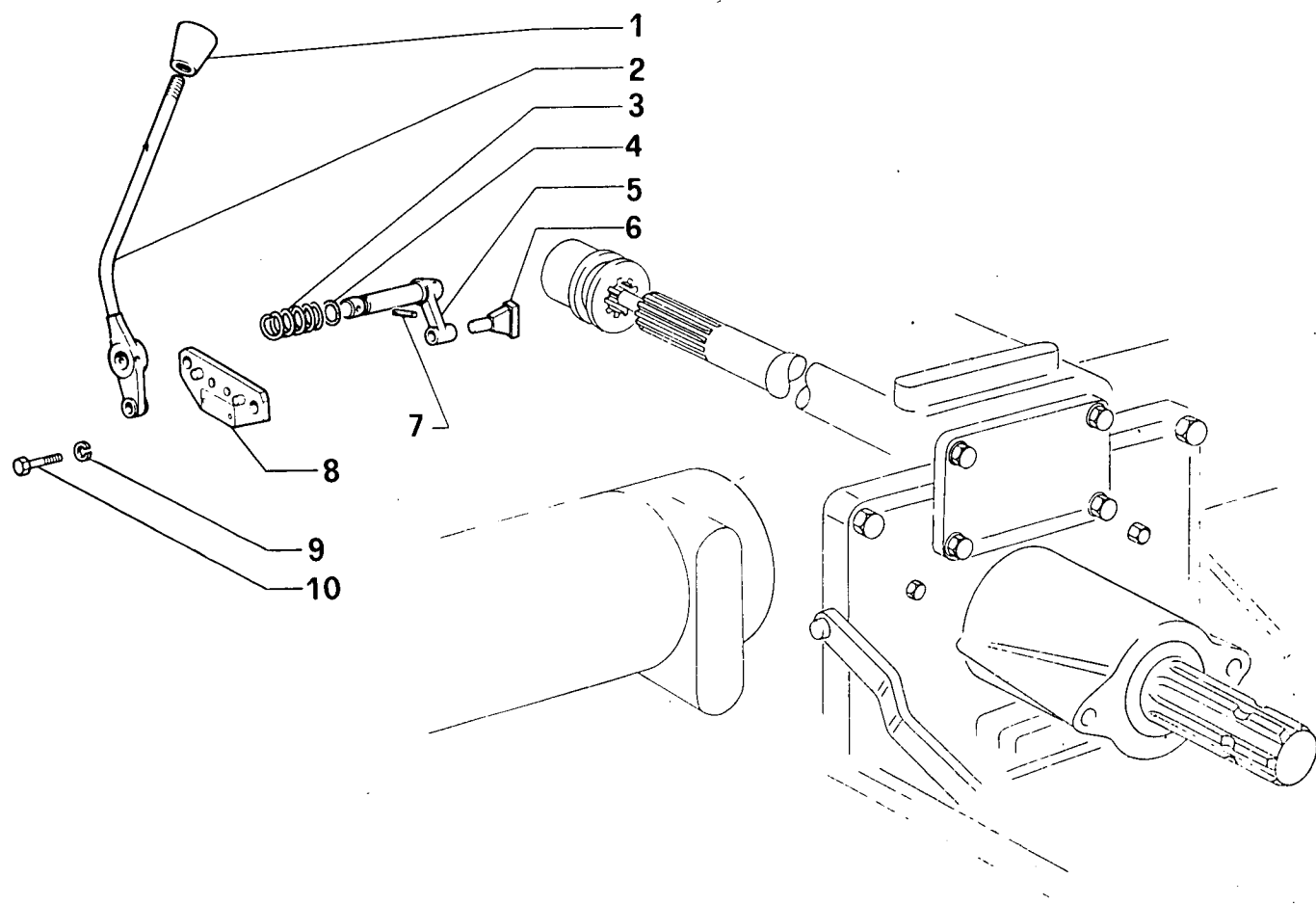

C80/50

COMANDO PRESA DI FORZA

60.08/01

(09-1981)

FIG	N. ORDINAZIONE	QTA	DENOMINAZIONE	DESIGNATION	BENENNUNG	DESCRIPTION	DENOMINACIONES
1	561880	1	IMPUGNATURA	POIGNEE	GRIF	KNOB	BOTON
2	562607	1	LEVA	LEVIER	HEBEL	LEVER	PALANCA
3	559699	1	MOLLA	RESSORT	FEDER	SPRING	RESORTE
4	577567	1	ANELLO OR	BAGUE TORIQUE	O-RING	O-SEAL	ANILLO O.
5	577566	1	LEVA RINVIO	LEVIER	HEBEL	LEVER	PALANCA
6	559701	1	PATTINO	PATIN	GLEITSTEIN	PAD	PATIN
7	14164170	1	SPINA ELASTICA	FICHE A RESSORT	FEDERSTECKER	CLIP PIN	CLAVIJA RESORTE
8	562610	1	SETTORE	TIRANT	SPREIZTANGE	STRUT	BIELA
9	10516671	2	ROSETTA DI SICUREZZA	RONDELLE FREIN	SICHERUNGSRING	LOCKWASHER	ARANDELA DE FRENO
10	16043221	2	VITE	VIS	SCHRAUBE	SCREW	TORNILLO

C80.50

01 02 03

COFANO

Capot
Haube

Hood
Capot

70.2/1

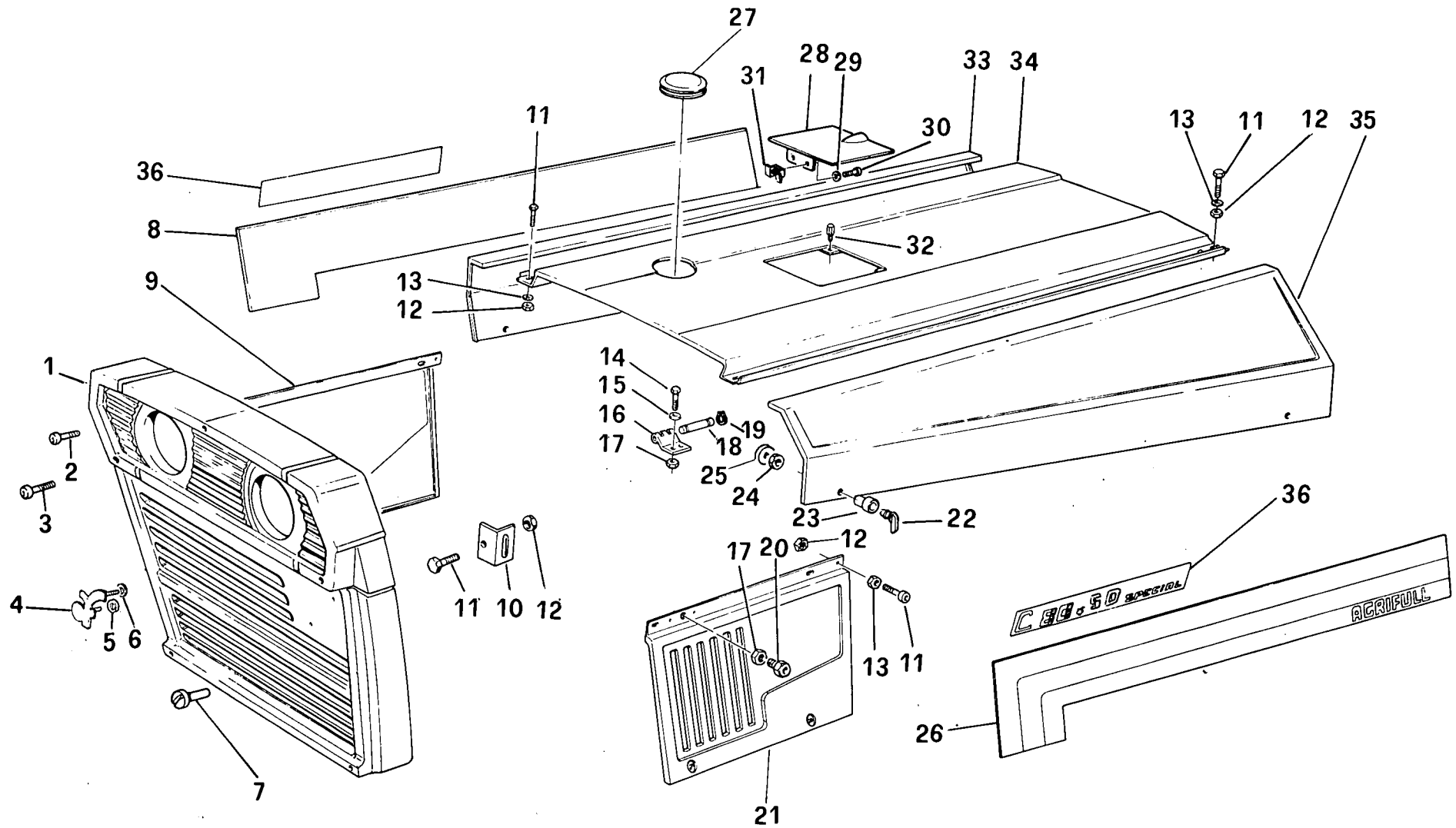

C80/50

COFANO

70.02/01

(09-1981)

FIG	N. ORDINAZIONE	QTA	DENOMINAZIONE	DÉSIGNATION	BENENNUNG	DESCRIPTION	DENOMINACIONES
1	44900848	1	FRONTALE COFANO	PAROI FRONT. CAPOT	HAUBENSTIRNWAND	HOOD FRONT	TABIQ. FRONTAL CAPO
2	13979611	1	VITE	VIS	SCHRAUBE	SCREW	TORNILLO
3	13280411	2	VITE	VIS	SCHRAUBE	SCREW	TORNILLO
4	44901336	1	FREGIO	MOTIF	ZIERSTUECK	ORNAMENT	EMBELLECEDOR
5	44901311	2	ANELLO DI GOMMA	BAGUE CAOUTCHOUC	GUMMIRING	RUBBER RING	GUARNICION DE CAUCHO
6	44901313	2	MOLLETTA DI FISSAGGIO	AGRAFE	KLEMMSTUECK	CLIP	SUJETA DOR
7	44901407	2	VITE	VIS	SCHRAUBE	SCREW	TORNILLO
8	44900851	1	DECALCOMANIA DX	DECALCOMANIE	ABZIEHBILD	DECAL	CALCOMANIA
9	5119581	1	FIANCHETTO DX	TABLIER	SEITENBLECH	SIDE PANEL	COSTADO
10	44901448	2	SQUADRETTA	EQUERRE	HALTER	BRACKET	APOYO
11	16043221	20	VITE	VIS	SCHRAUBE	SCREW	TORNILLO
12	16100811	6	DADO	ECROU	MUTTER	NUT	TUERCA
13	44901291	4	ROSETTA DI SICUREZZA	RONDELLE FREIN	SICHERUNGSRING	LOCKWASHER	ARANDELA DE FRENO
14	10902121	8	VITE	VIS	SCHRAUBE	SCREW	TORNILLO
15	10519411	8	ROSETTA DI SICUREZZA	RONDELLE FREIN	SICHERUNGSRING	LOCKWASHER	ARANDELA DE FRENO
16	44901146	4	CERNIERA COFANO	CHARNIERE DE CAPOT	HAUBENSCHARNIER	HOOD HINGE	BISAGRA CAPOT
17	15896211	14	DADO	ECROU	MUTTER	NUT	TUERCA
18	44901147	4	PERNO	AXE	BOLZEN	PIN	EJE
19	11087676	8	ANELLO DI SICUREZZA	ARRETOIR	SICHERUNGSRING	LOCKRING	ANILLO DE FRENO
20	5116537	6	TASSELLO	TAMPON	BEILAGE	PAD	TACO
21	5119585	1	FIANCHETTO SX	TABLIER	SEITENBLECH	SIDE PANEL	COSTADO
22	44901154	4	VITE	VIS	SCHRAUBE	SCREW	TORNILLO
23	44901152	4	GHIERA	VIROLE	GEWINDERING	PLUG	VIROLA
24	10791411	4	DADO	ECROU	MUTTER	NUT	TUERCA
25	44901153	4	ANELLO DI GOMMA	BAGUE CAOUTCHOUC	GUMMIRING	RUBBER RING	GUARNICION DE CAUCHO
26	44900852	1	DECALCOMANIA SX	DECALCOMANIE	ABZIEHBILD	DECAL	CALCOMANIA
27	44900905	1	TAPPO	BOUCHON	STOPFEN	PLUG	TAPON
28	599122	1	SPORTELLO	VOLET	DECKEL	LID	TAPA
29	10519401	2	ROSETTA DI SICUREZZA	RONDELLE FREIN	SICHERUNGSRING	LOCKWASHER	ARANDELA DE FRENO
30	13276011	2	VITE	VIS	SCHRAUBE	SCREW	TORNILLO
31	44901790	2	DADO	ECROU	MUTTER	NUT	TUERCA
32	4068085	2	TASSELLO	TAMPON	BEILAGE	PAD	TACO
33	44900897	1	FIANCHETTO SUP. DX	TABLIER	SEITENBLECH	SIDE PANEL	COSTADO
34	44900896	1	COPERCHIO COFANO	COUVERCLE	DECKEL	COVER	TAPA

CEO 50

01 02 03

COFANO

Capot
Haube

Hood
Capot

70.2/1

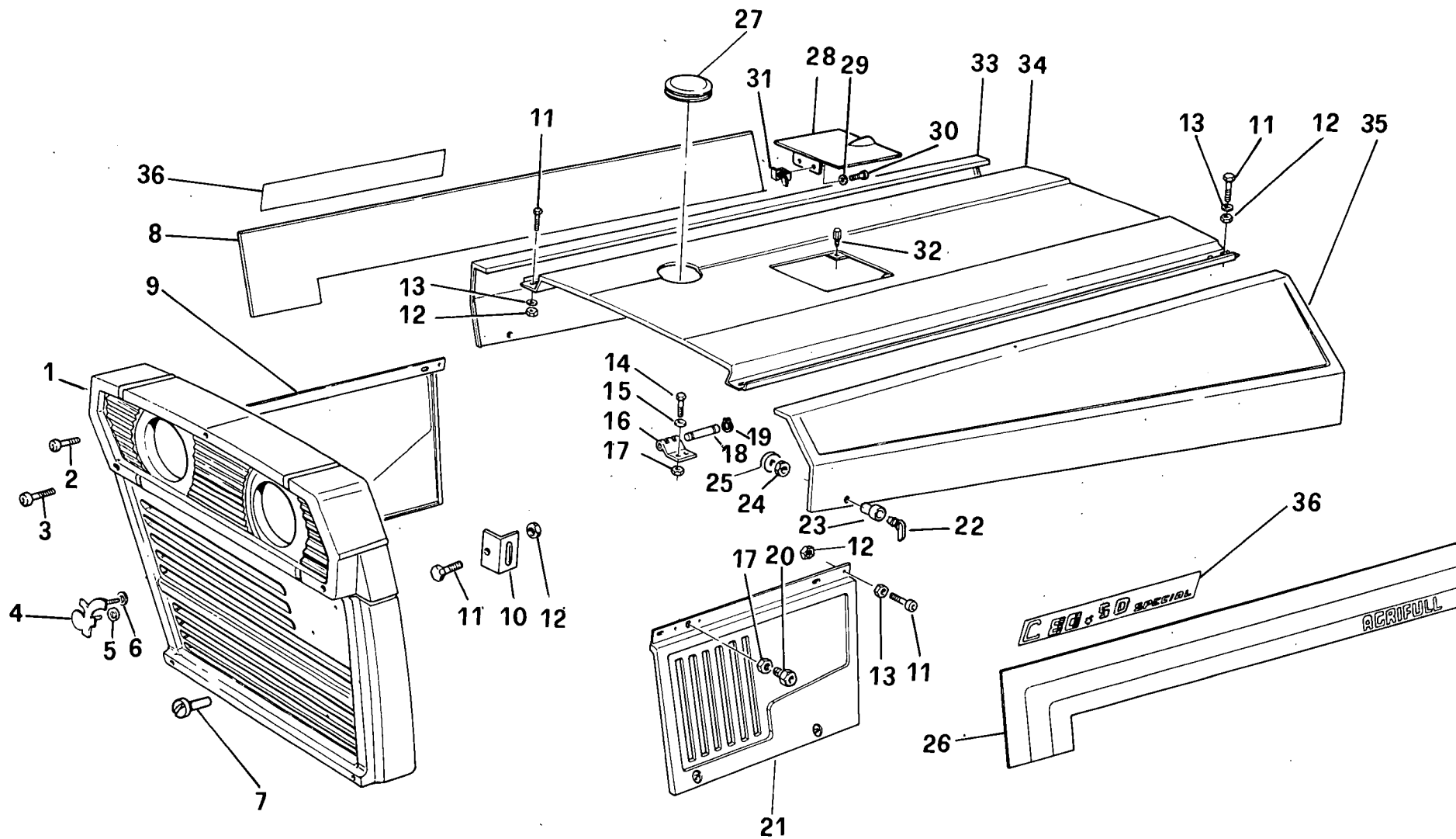

C80/50

COFANO

70.02/01

(09-1981)

FIG	N. ORDINAZIONE	QTA	DENOMINAZIONE	DESIGNATION	BENENNUNG	DESCRIPTION	DENOMINACIONES
35	44900897	1	FIANCHETTO SUP. SX	TABLIER	SEITENBLECH	SIDE PANEL	COSTADO
36	44901410	2	DECALCOMANIA LATERALE (01)	DECALCOMANIE	ABZIEHBILD	DECAL	CALCOMANIA
36	44901416	2	DECALCOMANIA LATERALE (02)	DECALCOMANIE	ABZIEHBILD	DECAL	CALCOMANIA
37	44901418	2	DECALCOMANIA LATERALE (03)	DECALCOMANIE	ABZIEHBILD	DECAL	CALCOMANIA

C80.50

01 02 03

SUPPORTI

70.3/1

Support
Lager

Support
Soporte

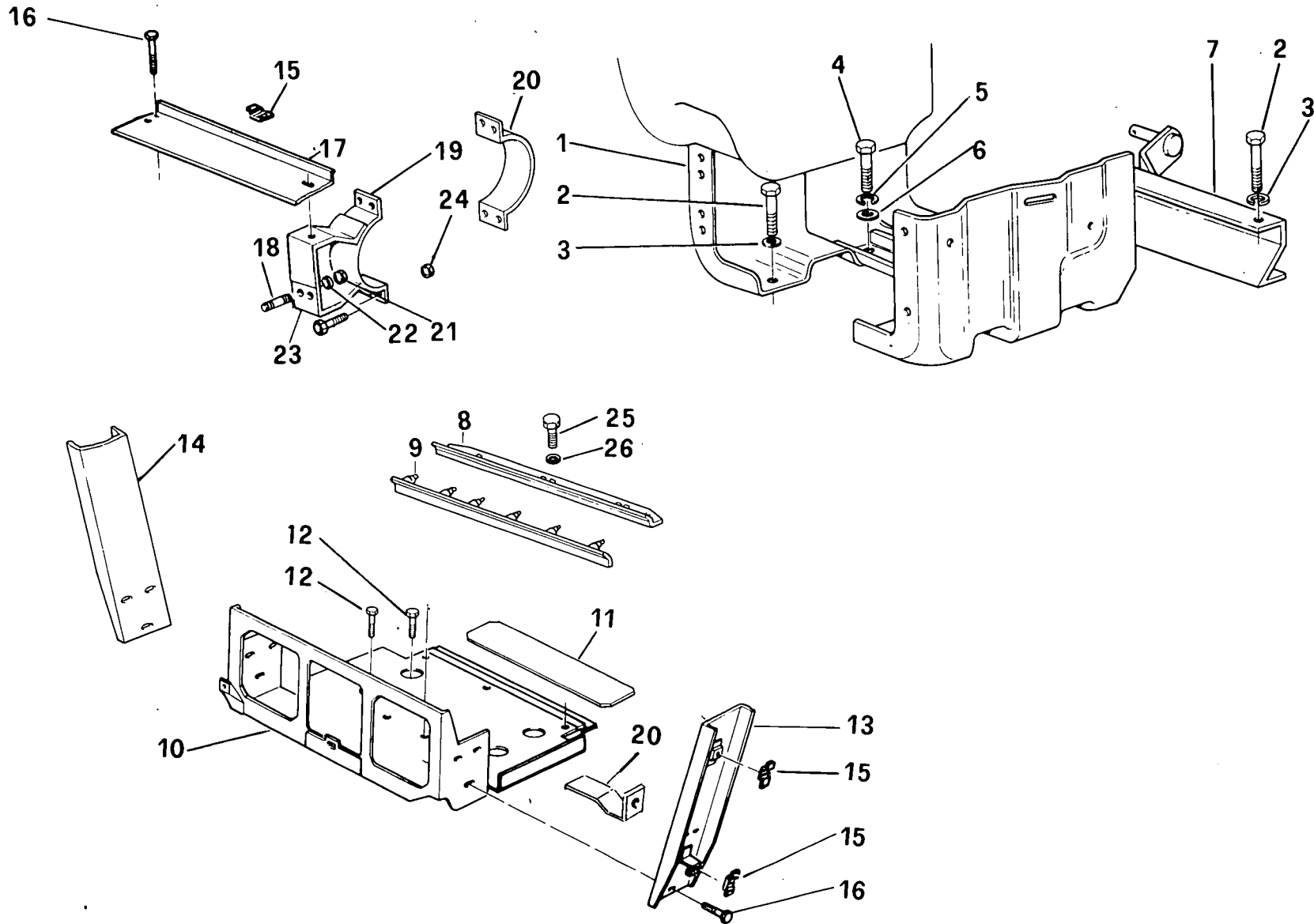

C80/50

SUPPORTI

70.03/01

(09-1981)

FIG	N. ORDINAZIONE	QTA	DENOMINAZIONE	DESIGNATION	BENENNUNG	DESCRIPTION	DENOMINACIONES
1	4956828	1	SUPPORTO SERBATOIO	SUPPORT RESERVOIR	TANKUNTERLAGE	SUPPORT/PAD	BASE PORTA-TANQUE
2	15540321	6	VITE	VIS	SCHRAUBE	SCREW	TORNILLO
3	10517071	6	ROSETTA DI SICUREZZA	RONDELLE FREIN	SICHERUNGSRING	LOCKWASHER	ARANDELA DE FRENO
4	11422321	2	VITE	VIS	SCHRAUBE	SCREW	TORNILLO
5	10517171	2	ROSETTA DI SICUREZZA	RONDELLE FREIN	SICHERUNGSRING	LOCKWASHER	ARANDELA DE FRENO
6	10520001	2	ROSETTA PIANA	RONDELLE	SCHEIBE	WASHER	ARANDELA
7	4956888	1	MENSOLA	CONSOLE	STUETZE	REINFORCEMENT	REFUERZO
8	4978731	1	TRAVERSA	TRAVERSE	TRAVVERSE	CROSSRAIL	TRAVESANO
9	4975018	1	TASSELLO	TAMPON	BEILAGE	PAD	TACO
10	5117579	1	SUPPORTO BATTERIA	SUPPORT BATTERIE	BATTERIETRAEGER	BATTERY CARRIER	PORTA-BATERIA
11	4997629	1	PIASTRA APPOGGIO	PLAQUE	PLATTE	PLATE	PLACA
12	15540221	4	VITE	VIS	SCHRAUBE	SCREW	TORNILLO
13	5116508	1	SUPPORTO SX	SUPPORT	LAGER	SUPPORT	SOPORTE
14	5116516	1	SUPPORTO DX	SUPPORT	LAGER	SUPPORT	SOPORTE
15	5116031	4	DADO IN GABBIA	ECROU	MUTTER	NUT	TUERCA
16	16043221	10	VITE	VIS	SCHRAUBE	SCREW	TORNILLO
17	5117580	1	SUPPORTO FRONTALE	SUPPORT	LAGER	SUPPORT	SOPORTE
18	15970721	2	VITE	VIS	SCHRAUBE	SCREW	TORNILLO
19	10516871	2	ROSETTA DI SICUREZZA	RONDELLE FREIN	SICHERUNGSRING	LOCKWASHER	ARANDELA DE FRENO
20	5117600	2	STAFFA	ETRIER	HALTER	BRACKET	SOPORTE

CEB.50

01 02 03

CRUSCOTTO

Tablier
Stirnwand

Dash/panel
Tablero

70.4/1

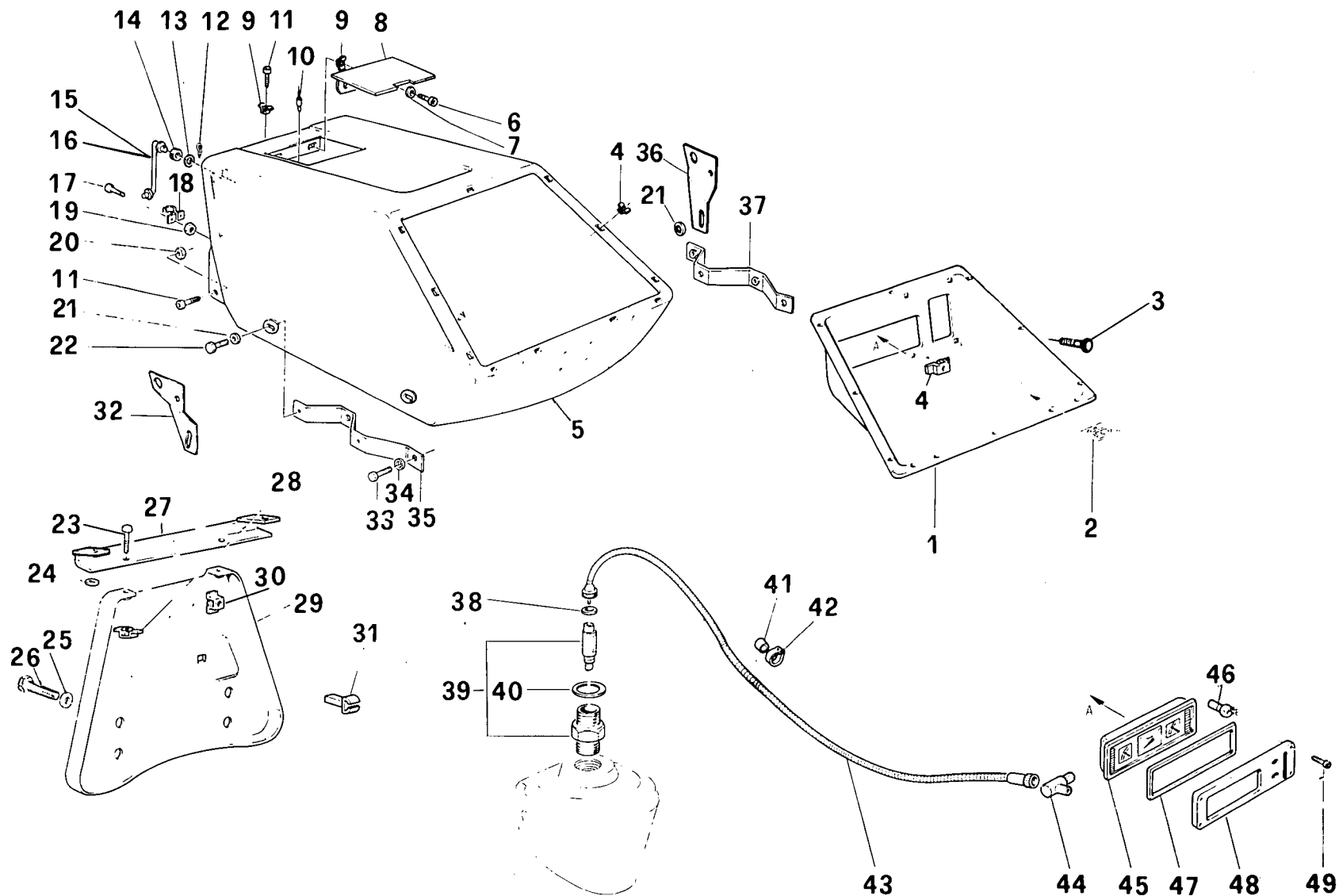

C80/50

CRUSCOTTO

70.04/01

(09-1981)

FIG	N. ORDINAZIONE	QTA	DENOMINAZIONE	DESIGNATION	BENENNUNG	DESCRIPTION	DENOMINACIONES
1	5119603	1	PLANCIA PORTASTRUMENTI	PLANCHE DE BORD	INSTRUMENTENBRETT	INSTRUMENT PANEL	TABLERO DE INSTRUMENTOS
2	594215	1	TARGHETTA	PLAQUETTE	SCHILD	PLATE	PLACA
3	13311011	9	VITE	VIS	SCHRAUBE	SCREW	TORNILLO
4	44901164	15	DADO	ECROU	MUTTER	NUT	TUERCA
5	44901427	1	CRUSCOTTO	TABLIER	STIRNWAND	DASH/PANEL	TABLERO
6	13276011	2	VITE	VIS	SCHRAUBE	SCREW	TORNILLO
7	10519401	2	ROSETTA DI SICUREZZA	RONDELLE FREIN	SICHERUNGSRING	LOCKWASHER	ARANDELA DE FRENO
8	599122	1	SPORTELLA	VOLET	DECKEL	LID	TAPA
9	44901790	3	DADO	ECROU	MUTTER	NUT	TUERCA
10	4068085	2	TASSELLO	TAMPON	BEILAGE	PAD	TACO
11	5116537	3	TASSELLO	TAMPON	BEILAGE	PAD	TACO
12	10734401	2	COPIGLIA	GOUPILLE	SPLINT	SPLIT PIN	PASADOR ABIERTO
13	10519601	2	ROSETTA DI SICUREZZA	RONDELLE FREIN	SICHERUNGSRING	LOCKWASHER	ARANDELA DE FRENO
14	10396180	2	ANELLO DI GOMMA	BAGUE CAOUTCHOUC	GUMMIRING	RUBBER RING	GUARNICION DE CAUCHO
15	5119579	1	PUNTONE DX	ETAI	STREBE	STRUT	TORNAPUNTA
16	5119577	1	PUNTONE SX	ETAI	STREBE	STRUT	TORNAPUNTA
17	13274011	4	VITE	VIS	SCHRAUBE	SCREW	TORNILLO
18	567281	2	MOLLA	RESSORT	FEDER	SPRING	RESORTE
19	15896411	4	DADO	ECROU	MUTTER	NUT	TUERCA
20	15896211	2	DADO	ECROU	MUTTER	NUT	TUERCA
21	4998710	2	ROSETTA DI SICUREZZA	RONDELLE FREIN	SICHERUNGSRING	LOCKWASHER	ARANDELA DE FRENO
22	16043221	4	VITE	VIS	SCHRAUBE	SCREW	TORNILLO
23	10979321	2	VITE	VIS	SCHRAUBE	SCREW	TORNILLO
24	13550401	2	ROSETTA PIANA	RONDELLE	SCHEIBE	WASHER	ARANDELA
25	10516870	4	ROSETTA DI SICUREZZA	RONDELLE FREIN	SICHERUNGSRING	LOCKWASHER	ARANDELA DE FRENO
26	15970521	4	VITE	VIS	SCHRAUBE	SCREW	TORNILLO
27	5118210	1	TRAVERSA	TRAVERSE	TRAVERSE	CROSSRAIL	TRAVESANO
28	4998680	2	DADO	ECROU	MUTTER	NUT	TUERCA
29	4988024	1	PLANCIA	PLANCHE	WAND	PANEL	TABLERO
30	4988025	7	DADO	ECROU	MUTTER	NUT	TUERCA
31	14575780	1	MOLLETTA	AGRAFE	KLAMMER	CLIP	PINZA
32	5118211	1	STAFFA SX	ETRIER	HALTER	BRACKET	SOPORTE
33	15970321	4	VITE	VIS	SCHRAUBE	SCREW	TORNILLO
34	44901291	4	ROSETTA DI SICUREZZA	RONDELLE FREIN	SICHERUNGSRING	LOCKWASHER	ARANDELA DE FRENO

CB50

01 02 03

CRUSCOTTO

Tablier
Stirnwand

Dash/panel
Tablero

70.4/1

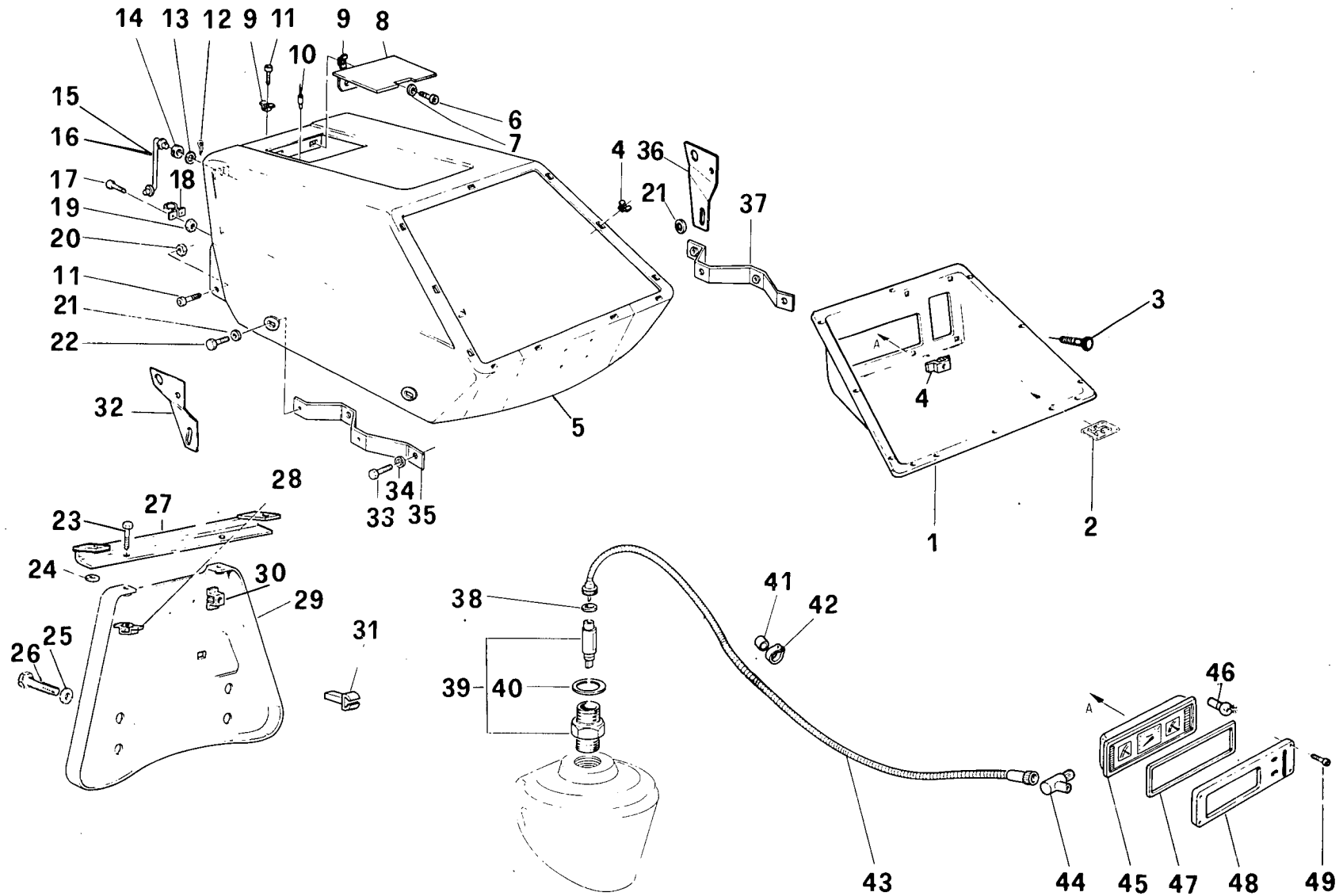

C80/50

CRUSCOTTO

70.04/01

(09-1981)

FIG	N. ORDINAZIONE	QTA	DENOMINAZIONE	DESIGNATION	BENENNUNG	DESCRIPTION	DENOMINACIONES
35	5117585	1	SUPPORTO SX	SUPPORT	LAGER	SUPPORT	SOPORTE
36	5118212	1	STAFFA DX	ETRIER	HALTER	BRACKET	SOPORTE
37	5117583	1	SUPPORTO DX	SUPPORT	LAGER	SUPPORT	SOPORTE
38	4998870	1	GUARNIZIONE	GARNITURE	DICHTUNG	GASKET	JUNTA
39	4717707	1	RACCORDO COMPL.	RACCORD	STUTZEN	CONNECTION	RACOR
40	13400575	1	ANELLO DI SICUREZZA	ARRETOIR	SICHERUNGSRING	LOCKRING	ANILLO DE FRENO
41	849603	1	ANELLO DI PROTEZIONE	ANNEAU DE GARDE	SCHUTZRING	PROTECTIVE RING	ANILLO PROTECCION
42	4951136	1	STAFFETTA FISSAGGIO	COLLIER	HALTER	RETAINER	ABRAZADERA
43	44017955	1	TRASMISSIONE FLEX	TRANSMISSION FLEXIBLE	BIEGSAME WELLE	FLEXIBLE SHAFT	ARBOL FLEXIBLE
44	5109356	1	RINVIO ANGOLARE	RENOVI D'ANGLE	WINKELANTRIEB	MITER GEARING	REENVIO ANGULAR
45	44901604	1	STRUMENTO A PIU° INDICAZ.	COMBINE A PLUSIEURS IND.	KOMBIINSTRUMENT	INST./CLUSTER	CUADRO DE SENAL MULTIPLE
46	14142390	1	LAMPADA	LAMPE	LAMPE	BULB	BOMBILLA
47	4998391	1	GUARNIZIONE DI TENUTA	JOINT	DICHTUNG	GASKET	JUNTA
48	44901865	1	PORTA STRUMENTI	PORTE INSTRUMENT	INSTRUMENTHALTER	INSTRUMENTHOLDER	PORTA INSTRUMENTO
49	13274911	6	VITE	VIS	SCHRAUBE	SCREW	TORNILLO

C80.50

01 02

SEDILE

Siège
Sitz

Seat
Butaca

70.5/1

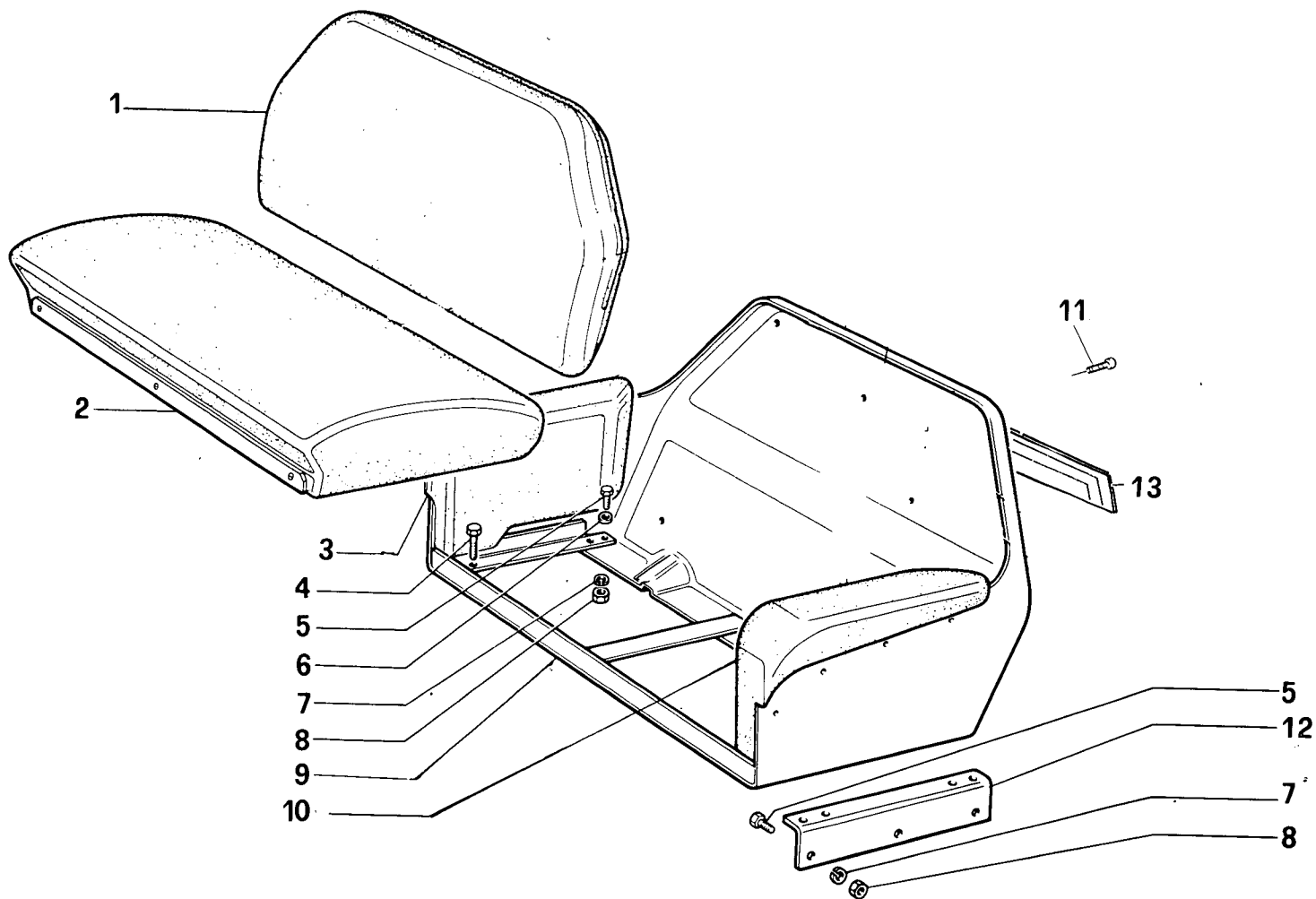

C80/50

SEDILE CONDUTTORE

70.05/01

(09-1981)

FIG	N. ORDINAZIONE	QTA	DENOMINAZIONE	DESIGNATION	BENENNUNG	DESCRIPTION	DENOMINACIONES
1	4996825	1	SCHIENALE	DOSSIER	RUECKENLEHNE	BACK	RESPALDO
2	4996823	1	CUSCINO	COUSSIN	SITZPOLSTER	CUSHION	ASIENTO
3	4996827	1	BRACCIUOLO DX	ACCOUDOIR	ARMLEHNE	ARMREST	BRACERO
4	11306921	2	VITE	VIS	SCHRAUBE	SCREW	TORNILLO
5	15970621	8	VITE	VIS	SCHRAUBE	SCREW	TORNILLO
6	12638601	4	ROSETTA PIANA	RONDELLE	SCHEIBE	WASHER	ARANDELA
7	10516871	8	ROSETTA DI SICUREZZA	RONDELLE FREIN	SICHERUNGSRING	LOCKWASHER	ARANDELA DE FRENO
8	12164711	10	DADO	ECROU	MUTTER	NUT	TUERCA
9	4981724	1	SUPPORTO SEDILE	CHEVALET DE SIEGE	SITZTRAEGER	SEAT CARRIER	PORTAASIENTO
10	4996828	1	BRACCIUOLO SX	ACCOUDOIR	ARMLEHNE	ARMREST	BRACERO
11	12237701	12	VITE	VIS	SCHRAUBE	SCREW	TORNILLO
12	4950689	2	MENSOLA	CONSOLE	STUETZE	REINFORCEMENT	REFUERZO
13	44900886	1	DECALCOMANIA	DECALCOMANIE	ABZIEHBILD	DECAL	CALCOMANIA

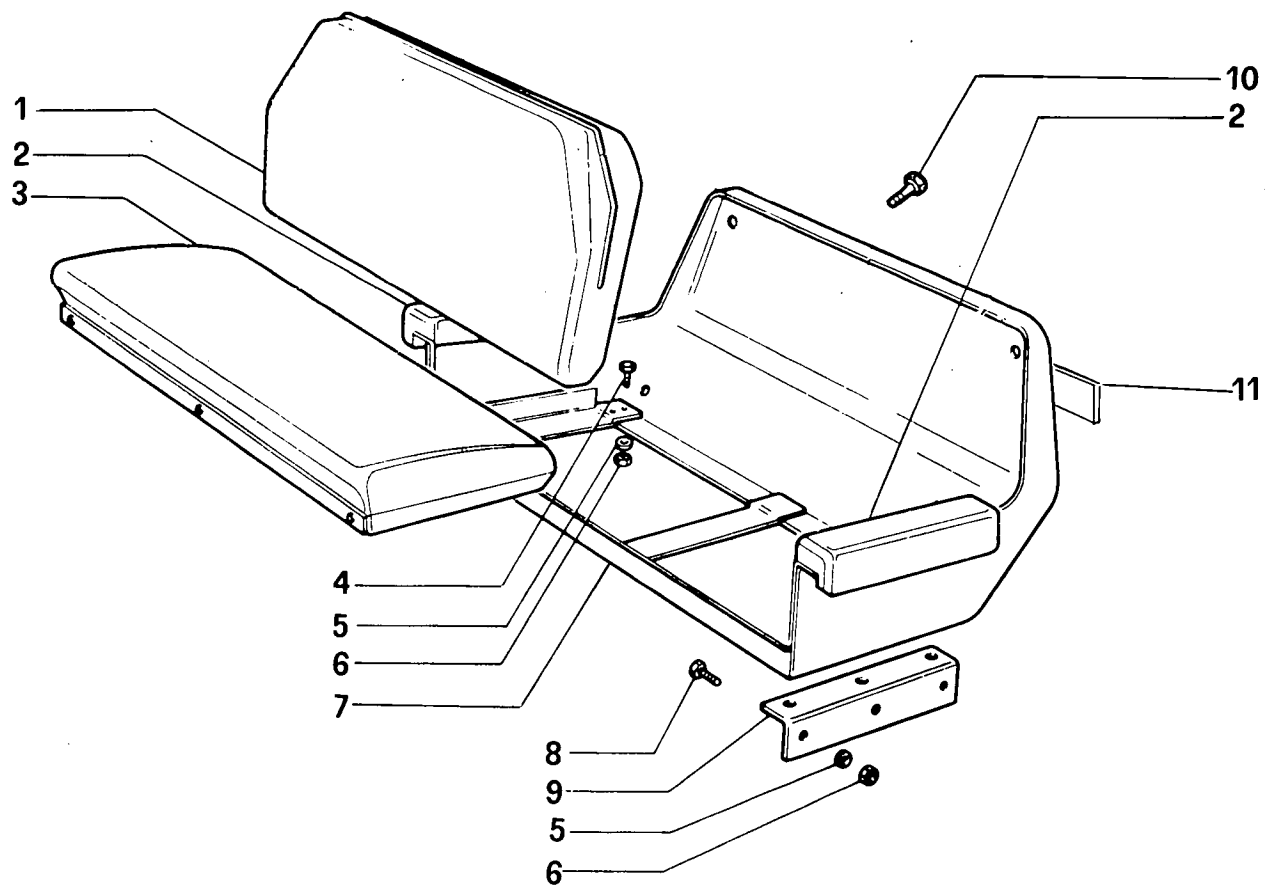

C80/50

SEDILE CONDUTTORE

70.05/02

(09-1981)

FIG	N. ORDINAZIONE	QTA	DENOMINAZIONE	DESIGNATION	BENENNUNG	DESCRIPTION	DENOMINACIONES
1	5106930	1	SCHIENALE	DOSSIER	RUECKENLEHNE	BACK	RESPALDO
2	5106928	2	BRACCIUOLO	ACCOUDOIR	ARMLEHNE	ARMREST	BRACERO
3	5106932	1	CUSCINO	COUSSIN	SITZPOLSTER	CUSHION	ASIENTO
4	15970721	5	VITE	VIS	SCHRAUBE	SCREW	TORNILLO
5	10516871	10	ROSETTA DI SICUREZZA	RONDELLE FREIN	SICHERUNGSRING	LOCKWASHER	ARANDELA DE FRENO
6	12164711	10	DADO	ECROU	MUTTER	NUT	TUERCA
7	4981884	1	SUPPORTO SEDILE	CHEVALET DE SIEGE	SITZTRAEGER	SEAT CARRIER	PORTAASIENTO
8	15970521	5	VITE	VIS	SCHRAUBE	SCREW	TORNILLO
9	4958117	2	MENSOLA	CONSOLE	STUETZE	REINFORCEMENT	REFUERZO
9	5118071	2	MENSOLA -820-	CONSOLE	STUETZE	REINFORCEMENT	REFUERZO
10	12237701	12	VITE	VIS	SCHRAUBE	SCREW	TORNILLO
11	44900886	1	DECALCOMANIA	DECALCOMANIE	ABZIEHBILD	DECAL	CALCOMANIA

PARAFANGHI E PEDANE

Ailes et marche-pieds
Kotflügel und Trittbretter

Mudguards and Footboards
Guardabarros y estribos

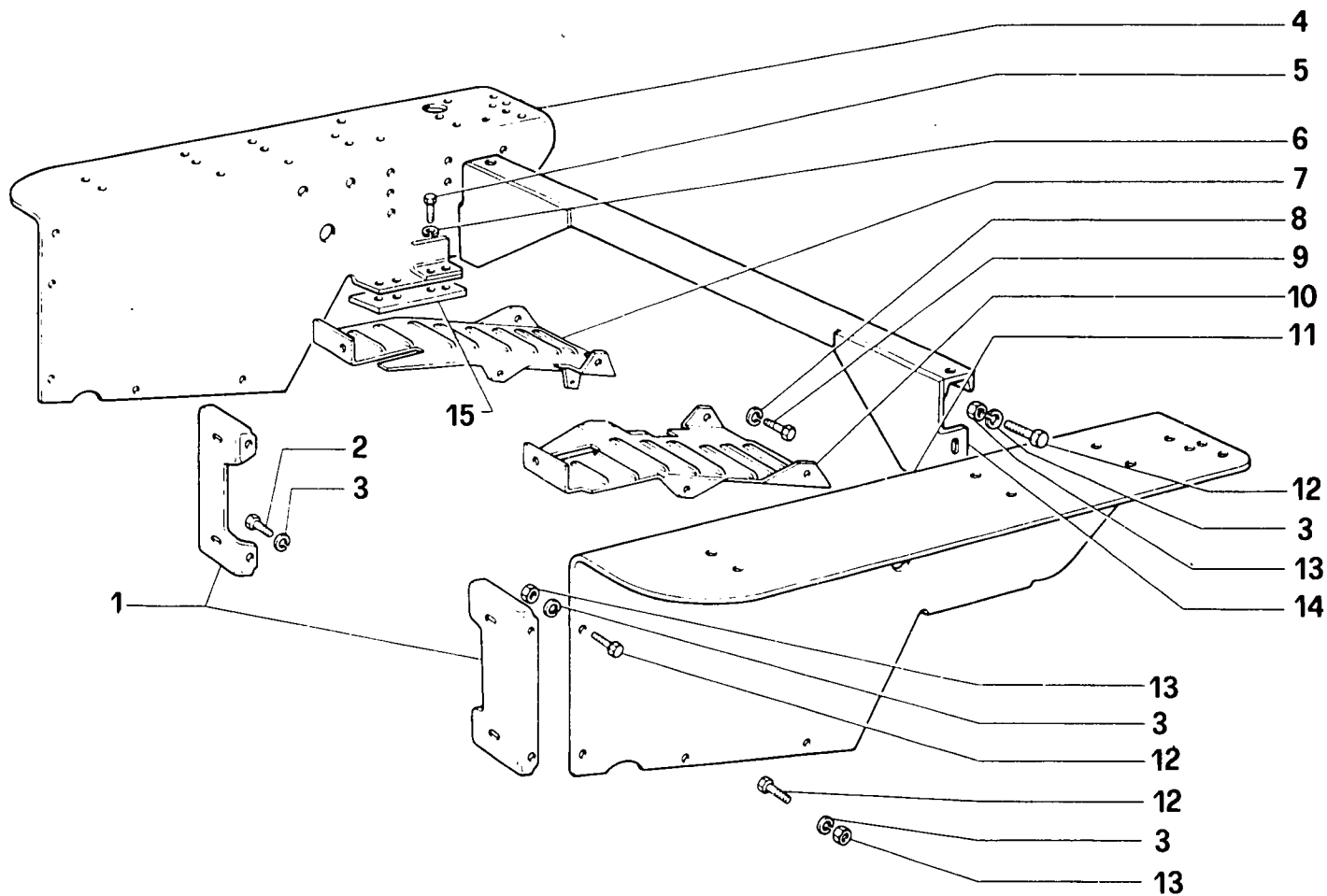

C80/50

PARAFANGHI E PEDANE

70.06/01

(09-1981)

FIG	N. ORDINAZIONE	QTA	DENOMINAZIONE	DESIGNATION	BENENNUNG	DESCRIPTION	DENOMINACIONES
1	599580	2	PIASTRA ANT.	PLAQUE	PLATTE	PLATE	PLACA
2	15970521	12	VITE	VIS	SCHRAUBE	SCREW	TORNILLO
3	10516871	16	ROSETTA DI SICUREZZA	RONDELLE FREIN	SICHERUNGSRING	LOCKWASHER	ARANDELA DE FRENO
4	4950544	1	PARAFANGO DX	AILE	KOTFLUEGEL	MUDGUARD	GUARDABARROS
5	11422321	2	VITE	VIS	SCHRAUBE	SCREW	TORNILLO
6	11408321	2	VITE	VIS	SCHRAUBE	SCREW	TORNILLO
7	10517171	4	ROSETTA DI SICUREZZA	RONDELLE FREIN	SICHERUNGSRING	LOCKWASHER	ARANDELA DE FRENO
8	599436	1	PEDANA DX	PLANCHER	TRITTBLECH	FOOTBOARD	ESTRIBO
9	10922921	4	VITE	VIS	SCHRAUBE	SCREW	TORNILLO
10	599437	1	PEDANA SX	PLANCHER	TRITTBLECH	FOOTBOARD	ESTRIBO
11	4950545	1	PARAFANGO SX	AILE	KOTFLUEGEL	MUDGUARD	GUARDABARROS
12	15970721	4	VITE	VIS	SCHRAUBE	SCREW	TORNILLO
13	12164711	12	DADO	ECROU	MUTTER	NUT	TUERCA
14	4952580	1	TRAVERSA	TRAVERSE	TRAVERSE	CROSSRAIL	TRAVESANO
15	4950546	2	SPESSORE	CALE	AUSGLEICHSCHLEIBE	SHIM	ARANDELA COMPENS.

*Ailes et marche-pieds
Kotflügel und Trittbretter*

*Mudguards and Footboards
Guardabarros y estribos*

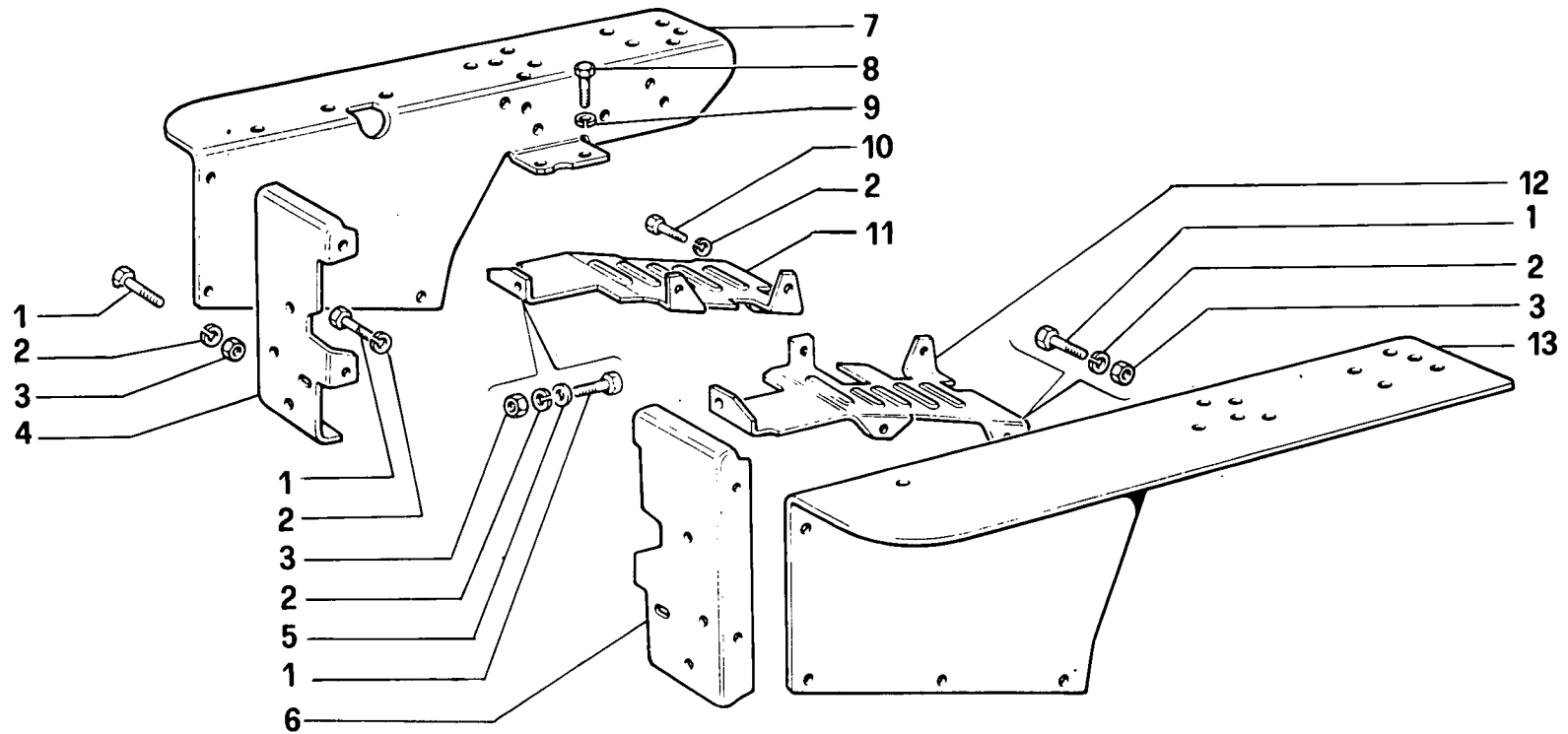

C80/50

PARAFANGHI E PEDANE

70.06/02

(09-1981)

FIG	N. ORDINAZIONE	QTA	DENOMINAZIONE	DESIGNATION	BENENNUNG	DESCRIPTION	DENOMINACIONES
1	15970521	14	VITE	VIS	SCHRAUBE	SCREW	TORNILLO
2	10516871	16	ROSETTA DI SICUREZZA	RONDELLE FREIN	SICHERUNGSRING	LOCKWASHER	ARANDELA DE FRENO
3	12164711	6	DADO	ECROU	MUTTER	NUT	TUERCA
4	4956776	1	PIASTRA DX	PLAQUE	PLATTE	PLATE	PLACA
5	12638601	2	ROSETTA PIANA	RONDELLE	SCHEIBE	WASHER	ARANDELA
6	4956777	1	PIASTRA SX	PLAQUE	PLATTE	PLATE	PLACA
7	4956791	1	PARAFANGO DX	AILE	KOTFLUEGEL	MUDGUARD	GUARDABARROS
8	15836421	4	VITE	VIS	SCHRAUBE	SCREW	TORNILLO
9	10517171	4	ROSETTA DI SICUREZZA	RONDELLE FREIN	SICHERUNGSRING	LOCKWASHER	ARANDELA DE FRENO
10	15970421	4	VITE	VIS	SCHRAUBE	SCREW	TORNILLO
11	4956839	1	PEDANA DX	PLANCHER	TRITTBLECH	FOOTBOARD	ESTRIBO
12	4956836	1	PEDANA SX	PLANCHER	TRITTBLECH	FOOTBOARD	ESTRIBO
13	4956788	1	PARAFANGO SX	AILE	KOTFLUEGEL	MUDGUARD	GUARDABARROS

C80.50

01 02 03

RIPARI CINGOLI

Protections de chenilles
Schutzbleche der Raupenkette

Track Covers
Blindaje de cadenas

70.7/1

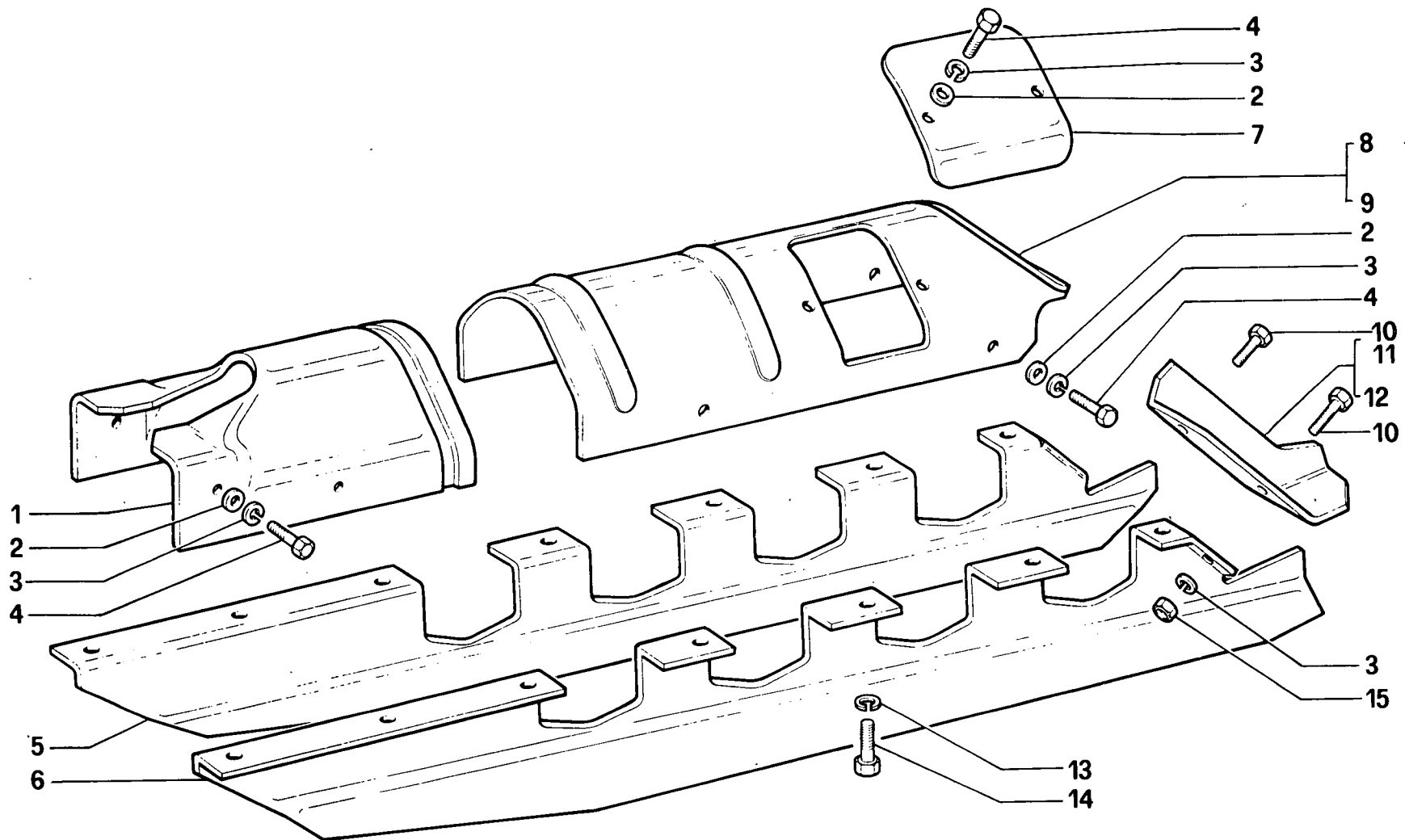

C80/50

RIPARI CINGOLI

70.07/01

(09-1981)

FIG	N. ORDINAZIONE	QTA	DENOMINAZIONE	DESIGNATION	BENENNUNG	DESCRIPTION	DENOMINACIONES
1	4960995	2	RIPARO ANT.	PROTECTION	ABDECKUNG	PROTECTION	DEFENSA
2	12638601	20	ROSETTA PIANA	RONDELLE	SCHEIBE	WASHER	ARANDELA
3	10516871	28	ROSETTA DI SICUREZZA	RONDELLE FREIN	SICHERUNGSRING	LOCKWASHER	ARANDELA DE FRENO
4	15970521	24	VITE	VIS	SCHRAUBE	SCREW	TORNILLO
5	4973165	1	RIPARO DX	PROTECTION	ABDECKUNG	PROTECTION	DEFENSA
6	4973166	1	RIPARO SX	PROTECTION	ABDECKUNG	PROTECTION	DEFENSA
7	4961001	1	SPORTELLO	VOLET	DECKEL	LID	TAPA
8	4960996	1	RIPARO POST. SX	PROTECTION	ABDECKUNG	PROTECTION	DEFENSA
9	4960999	1	RIPARO POST. DX	PROTECTION	ABDECKUNG	PROTECTION	DEFENSA
10	15970721	4	VITE	VIS	SCHRAUBE	SCREW	TORNILLO
11	4973167	1	RIPARO DX	PROTECTION	ABDECKUNG	PROTECTION	DEFENSA
12	4973168	1	RIPARO SX	PROTECTION	ABDECKUNG	PROTECTION	DEFENSA
13	10517071	32	ROSETTA DI SICUREZZA	RONDELLE FREIN	SICHERUNGSRING	LOCKWASHER	ARANDELA DE FRENO
14	15540221	32	VITE	VIS	SCHRAUBE	SCREW	TORNILLO
15	12164711	4	DADO	ECROU	MUTTER	NUT	TUERCA

SERBATOIO E TUBAZIONI

Réservoir et canalisations combustible
Kraftstofftank und Leitungen

Fuel Tank and Lines
Depósito de combustible y tuberías

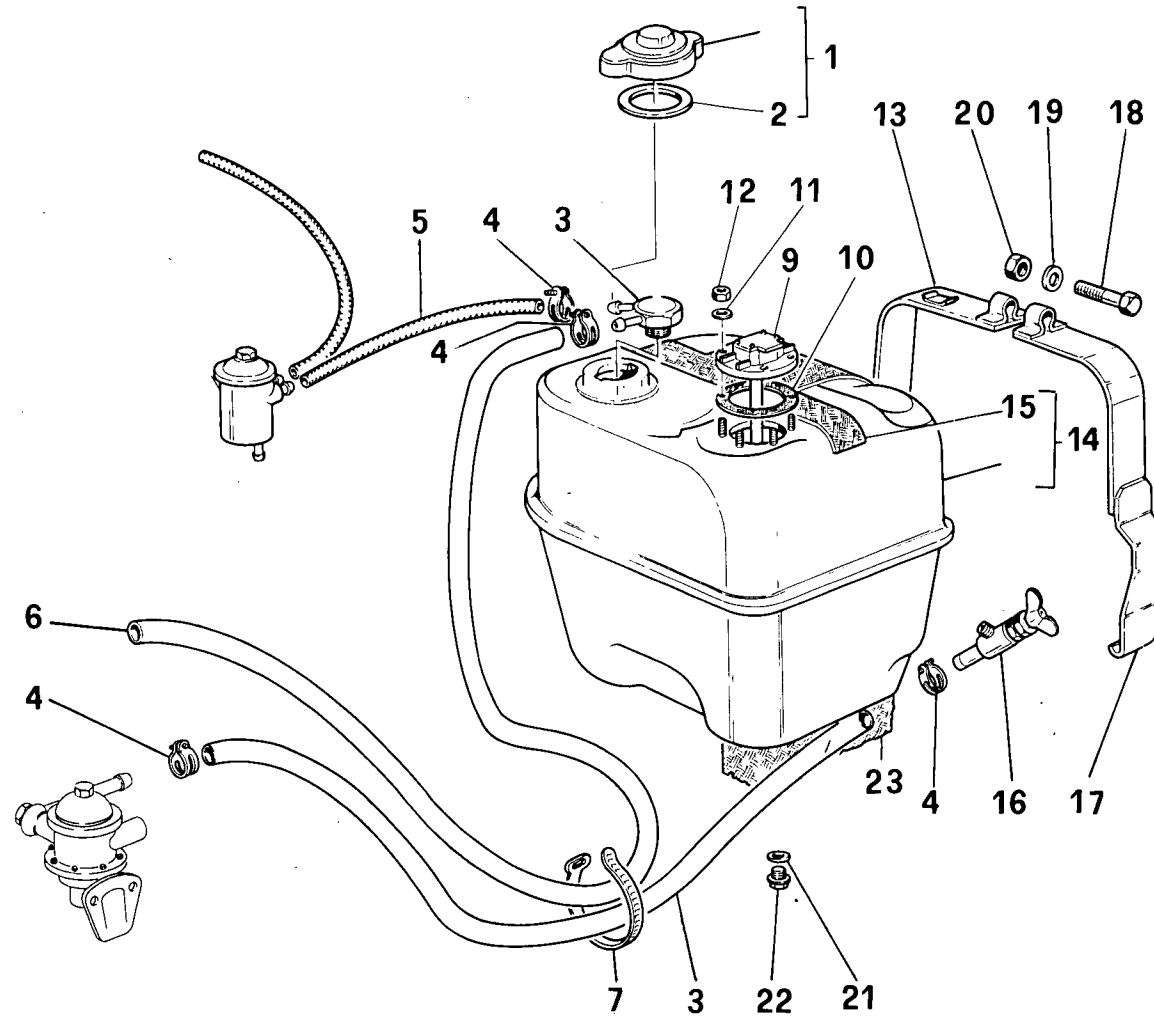

C80/50

SERBATOIO

80.01/01

(09-1981)

FIG	N. ORDINAZIONE	QTA	DENOMINAZIONE	DESIGNATION	BENENNUNG	DESCRIPTION	DENOMINACIONES
1	4117122	1	TAPPO SERBATOIO	BOUCHON	SCHRAUBDECKEL	CAP	TAPON
2	849496	1	GUARNIZIONE	GARNITURE	DICHTUNG	GASKET	JUNTA
3	4950863	1	BOCCHETTONE	VIS-RACCORD	HOLHLSCHRAUBE	UNION	BOQUILLA
4	12179490	6	COLLARE	COLLIER	SCHELLE	COLLAR	COLLAR
5	4952815	1	TUBO FLEX	TUBE/TUYAU	ROHR	PIPE/TUBE	TUBO
6	4971553	1	TUBO FLEX	TUBE/TUYAU	ROHR	PIPE/TUBE	TUBO
7	10007109	6	COLLARE	COLLIER	SCHELLE	COLLAR	COLLAR
8	4952813	1	TUBO FLEX	TUBE/TUYAU	ROHR	PIPE/TUBE	TUBO
9	4998806	1	INDICATORE DI LIVELLO COMBUSTIBILE	INDICAT.DE NIVEAU	STANDANZEIGER	LEVEL GAUGE	INDICADOR DE NIVEL
10	992273	1	GUARNIZIONE	GARNITURE	DICHTUNG	GASKET	JUNTA
11	11195371	6	ROSETTA DI SICUREZZA	RONDELLE FREIN	SICHERUNGSRING	LOCKWASHER	ARANDELA DE FRENO
12	10794011	6	DADO	ECROU	MUTTER	NUT	TUERCA
13	4952816	1	STAFFA DX	ETRIER	HALTER	BRACKET	SOPORTE
14	4979602	1	SERBATOIO COMPL.	RESERVOIR	BEHAELTER	TANK	DEPOSITO
15	4952618	1	PROTEZIONE	PROTECTION	ABDECKUNG	SHIELD	DEFENSA
16	5109270	1	RUBINETTO	ROBINET	HARN	COCK	GRIFO
17	4952817	1	STAFFA SX	ETRIER	HALTER	BRACKET	SOPORTE
18	15971321	1	VITE	VIS	SCHRAUBE	SCREW	TORNILLO
19	12574511	1	DADO	ECROU	MUTTER	NUT	TUERCA
21	10264360	1	GUARNIZIONE	GARNITURE	DICHTUNG	GASKET	JUNTA
22	10305140	1	TAPPO	BOUCHON	STOPFEN	PLUG	TAPON
23	4952471	2	PROTEZIONE INFERIORE	PROTECTION	ABDECKUNG	SHIELD	DEFENSA

CEB.50

01 02 03

FILTRO ARIA BAGNO D'OLIO

Filtre à air
Luftfilter

Air Cleaner
Filtro de aire

80.1/2

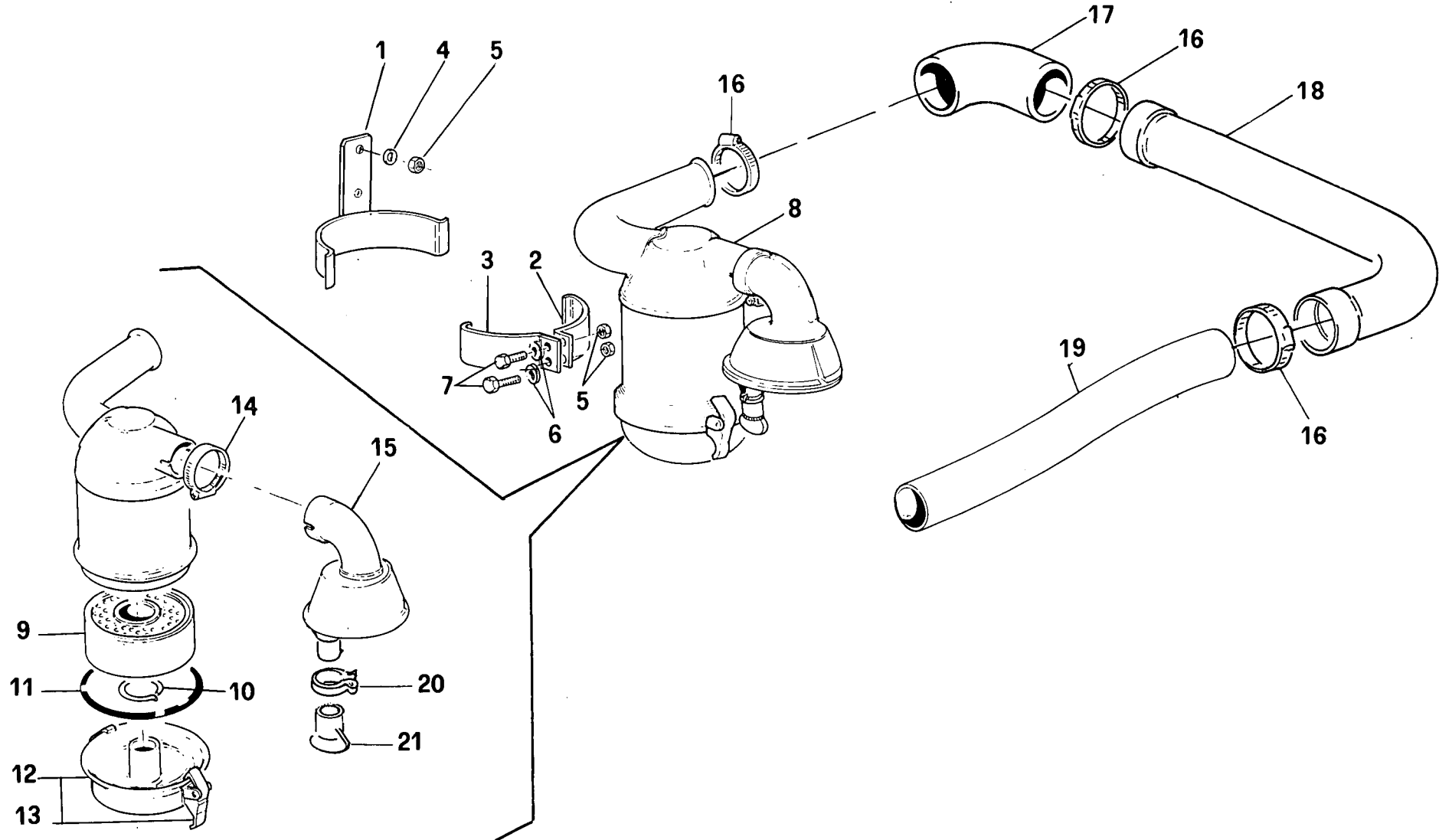

C80/50

FILTRO ARIA-BAGNO D'OLIO

80.01/02

(09-1981)

FIG	N. ORDINAZIONE	QTA	DENOMINAZIONE	DESIGNATION	BENENNUNG	DESCRIPTION	DENOMINACIONES
1	44901563	1	SUPPORTO FILTRO	SUPPORT DE FILTRE	FILTERTRAEGER	SUPPORT	PORTA-FILTRO
2	599155	1	STAFFA FILTRO	ETRIER	HALTER	BRACKET	SOPORTE
3	599154	1	STAFFA FILTRO	ETRIER	HALTER	BRACKET	SOPORTE
4	44901291	2	ROSETTA DI SICUREZZA	RONDELLE FREIN	SICHERUNGSRING	LOCKWASHER	ARANDELA DE FRENO
5	16104111	2	DADO	ECROU	MUTTER	NUT	TUERCA
6	10519601	2	ROSETTA DI SICUREZZA	RONDELLE FREIN	SICHERUNGSRING	LOCKWASHER	ARANDELA DE FRENO
7	16043821	2	VITE	VIS	SCHRAUBE	SCREW	TORNILLO
8	44901560	1	FILTRO COMPLETO	FILTRE	FILTER	FILTER	FILTRO
9	4963663	1	CARTUCCIA FILTRO	CARTOUCHE FILTRANT	FILTERPATRONE	CARTRIDGE	CARTUCHO FILTRO
10	553658	1	ANELLO DI SICUREZZA	ARRETOIR	SICHERUNGSRING	LOCKRING	ANILLO DE FRENO
11	553659	1	ANELLO DI TENUTA	JOINT D'ETANCHEITE	DICHTRING	SEAL	JUNTA HERMETICA
12	4973996	1	COPERCHIO	COUVERCLE	DECKEL	COVER	TAPA
13	553662	2	GANCIO	CROCHET	HAKEN	HOOK	GANCHO
14	12174890	1	FASCETTA	COLLIER	HALTEBAND	STRAP	ABRAZADERA
15	4959009	1	PREFILTRO	PREFILTRE	VORREINIGER	PRECLEANER	PREFILTRO
16	12174890	4	FASCETTA	COLLIER	HALTEBAND	STRAP	ABRAZADERA
17	5116481	1	MANICOTTO	MANCHON	MUFFE	SLEEVE	MANGUITO
18	44901561	1	TUBO DI COLLEGAMENTO	TUBE/TUYAU	ROHR	PIPE/TUBE	TUBO
19	44901527	1	MANICOTTO	MANCHON	MUFFE	SLEEVE	MANGUITO
20	12170790	1	FASCETTA	COLLIER	HALTEBAND	STRAP	ABRAZADERA
21	599501	1	VALVOLA	SOUPAPE	VENTIL	VALVE	VALVULA

CB0.50

01 02 03

FILTRO ARIA-(IRA0)

Filtre à air
Luftfilter

Air Cleaner
Filtro de aire

80.1/3

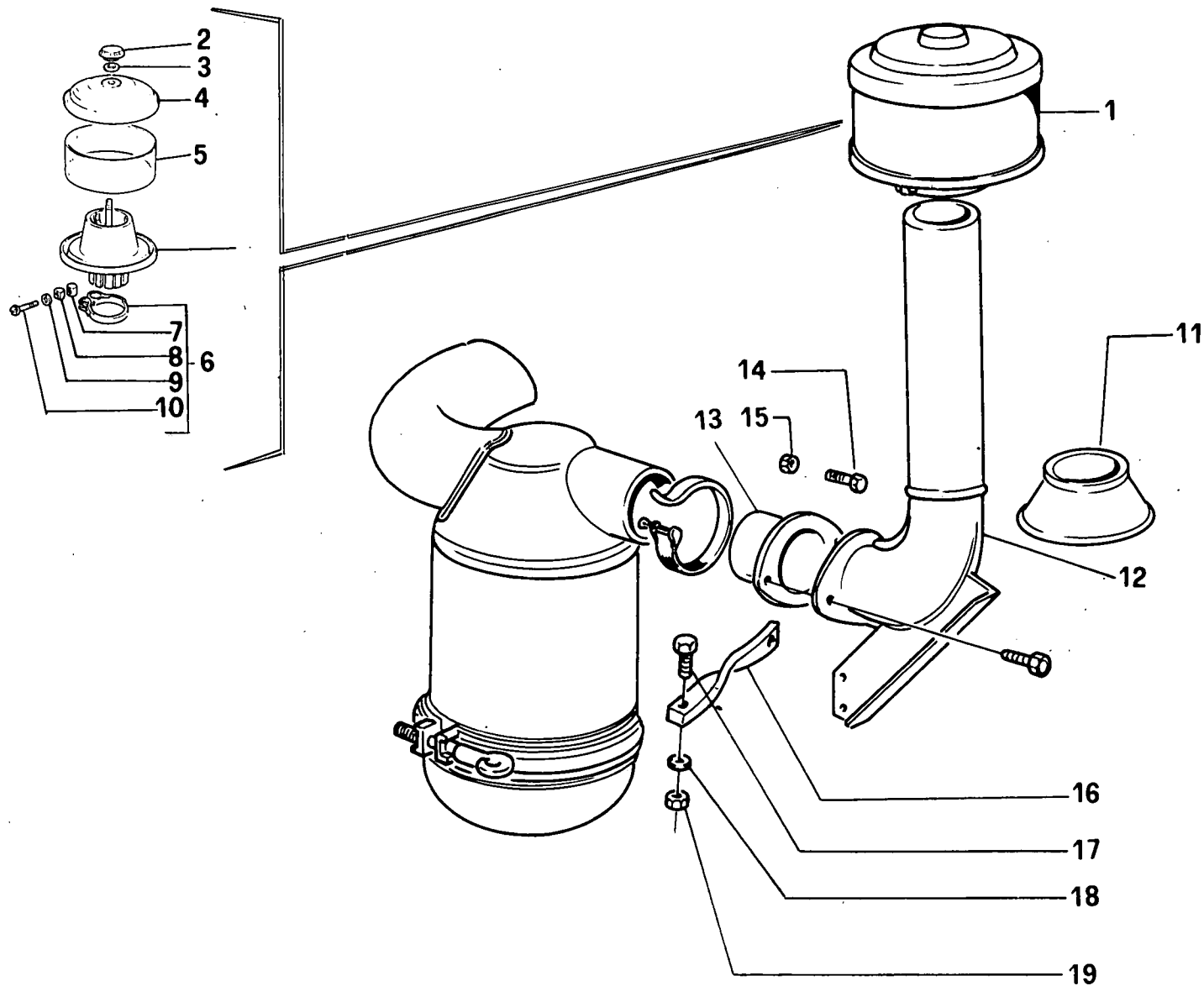

C80/50

PREFILTRO ARIA - IRAQ -

80.01/03

(09-1981)

FIG	N. ORDINAZIONE	QTA	DENOMINAZIONE	DESIGNATION	BENENNUNG	DESCRIPTION	DENOMINACIONES
1	4955800	1	PREFILTRO ARIA	PREFILTRE A AIR	VORREINIGER	PRE-FILTER	PREFILTRO DE AIRE
2	593738	1	POMELLO	BOUTON	KNEBELGRIFF	KNOB	BOTON
3	562515	1	GUARNIZIONE	GARNITURE	DICHTUNG	GASKET	JUNTA
4	4955799	1	COPERCHIO	COUVERCLE	DECKEL	COVER	TAPA
5	4955798	1	CORPO	CORPS	GEHAUSE	BODY	CUERPO
6	4955740	1	COLLARE	COLLIER	SCHELLE	COLLAR	COLLAR
7	4067156	1	TASSELLO	TAMPON	BEILAGE	PAD	TACO
8	4067155	1	TASSELLO	TAMPON	BEILAGE	PAD	TACO
9	12639701	1	ROSETTA DI SICUREZZA	RONDELLE FREIN	SICHERUNGSRING	LOCKWASHER	ARANDELA DE FRENO
10	4952488	1	VITE	VIS	SCHRAUBE	SCREW	TORNILLO
11	4957544	1	PROTEZIONE	PROTECTION	ABDECKUNG	SHIELD	DEFENSA
12	4957534	1	TUBO	TUBE/TUYAU	ROHR	PIPE/TUBE	TUBO
13	4957540	1	FLANGIA	BRIDE	FLANSCH	FLANGE	BRIDA
14	11106021	2	VITE	VIS	SCHRAUBE	SCREW	TORNILLO
15	11701711	1	DADO	ECROU	MUTTER	NUT	TUERCA
16	44981112	1	STAFFA	ETRIER	HALTER	BRACKET	SOPORTE
17	16043421	1	VITE	VIS	SCHRAUBE	SCREW	TORNILLO
18	44901291	1	ROSETTA DI SICUREZZA	RONDELLE FREIN	SICHERUNGSRING	LOCKWASHER	ARANDELA DE FRENO
19	16100811	1	DADO	ECROU	MUTTER	NUT	TUERCA

CEB 50

01 02 03

IMPIANTO ELETTRICO

Installation électrique
Elektroanlage

Electric sistem
Sistema eléctrico

80.4/1

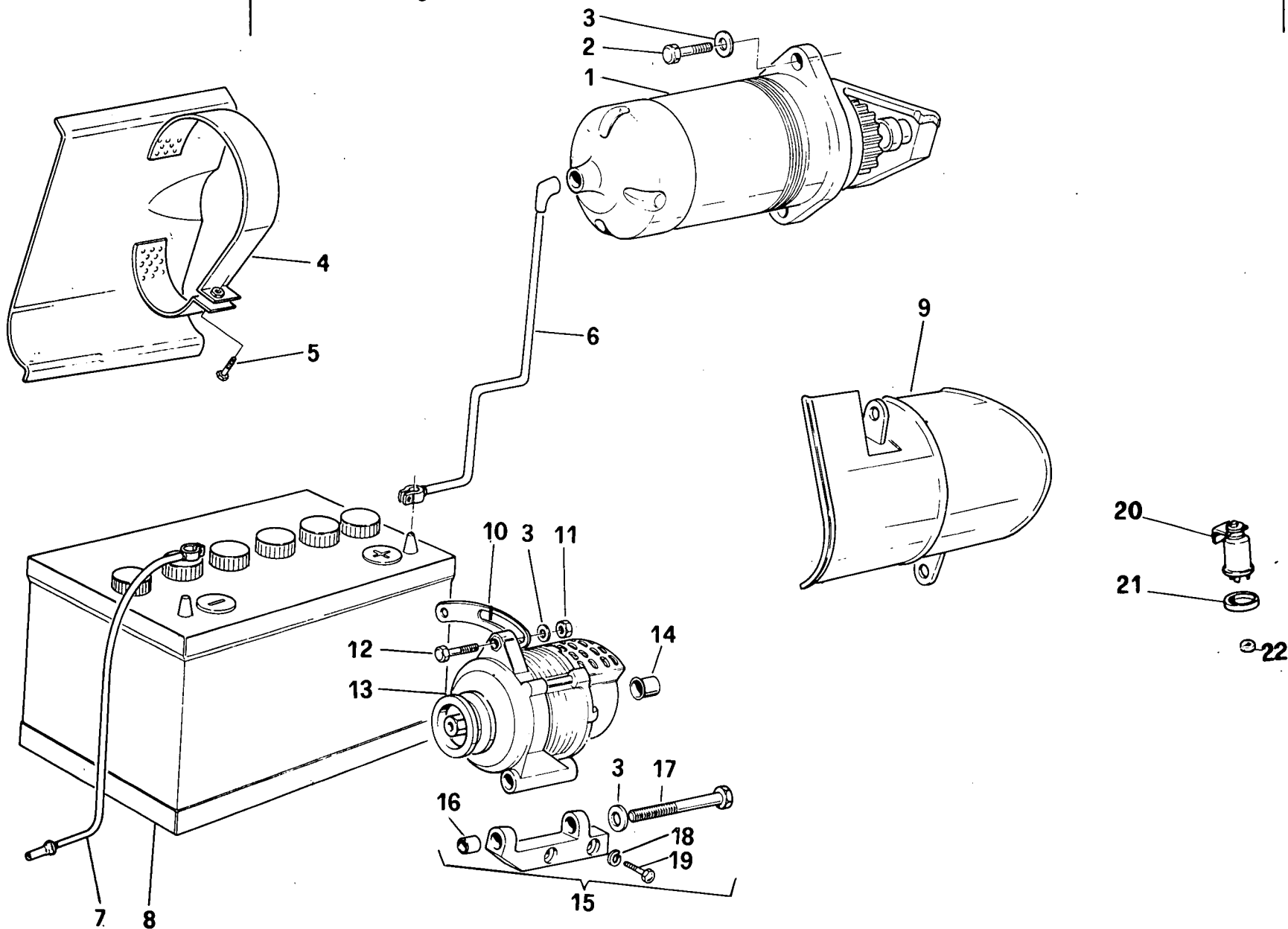

C80/50

IMPIANTO ELETTRICO

80.04/01

(09-1981)

FIG	N. ORDINAZIONE	QTA	DENOMINAZIONE	DESIGNATION	BENENNUNG	DESCRIPTION	DENOMINACIONES
1	5111319	1	MOTORINO D'AVVIAMENTO	DEMARREUR	ANLASSER	STARTER MOTOR	MOTOR DE ARRANQUE
2	11306921	3	VITE	VIS	SCHRAUBE	SCREW	TORNILLO
3	11198371	2	ROSETTA DI SICUREZZA	RONDELLE FREIN	SICHERUNGSRING	LOCKWASHER	ARANDELA DE FRENO
4	4721863	1	RIPARO	PROTECTION	ABDECKUNG	PROTECTION	DEFENSA
5	10902821	1	VITE	VIS	SCHRAUBE	SCREW	TORNILLO
6	44980899	1	CAVO +	CABLE	KABEL	CABLE	CABLE
7	44901570	1	BATTERIA	BATTERIE	BATTERIE	BATTERY	BATERIA
8	44980900	1	CAVO -	CABLE	KABEL	CABLE	CABLE
9	4702448	1	RIPARO	PROTECTION	ABDECKUNG	PROTECTION	DEFENSA
10	4702454	1	TENDITORE	TENDEUR	SPANNER	TENSIONER	ENSOR
11	12164711	2	DADO	ECROU	MUTTER	NUT	TUERCA
12	11306971	1	VITE	VIS	SCHRAUBE	SCREW	TORNILLO
13	4753104	1	ALTERNATORE	ALTERNATEUR	DREHSTROMLICHTMA- CHINE	ALTERNATOR	ALTERNADOR
14	10405585	1	CAPPUCCIO	CAPUCHON	STAUBSCHUTZKAPPE	BOOT	CAPUCHON
15	4702453	1	SUPPORTO	SUPPORT	LAGER	SUPPORT	SOPORTE
16	4702456	1	BOCCOLA	DOUILLE	BUECHSE	BUSH	CASQUILLO
17	4702457	1	VITE	VIS	SCHRAUBE	SCREW	TORNILLO
18	11198071	2	ROSETTA DI SICUREZZA	RONDELLE FREIN	SICHERUNGSRING	LOCKWASHER	ARANDELA DE FRENO
19	16044021	2	VITE	VIS	SCHRAUBE	SCREW	TORNILLO
20	4954117	1	LAMPEGGIATORE	CLIGNOTANT	BLINKGEBER	FLASHER	RELE' DE INTERMITEN- CIA
21	4967412	1	COPERCHIO INF.	COUVERCLE	DECKEL	COVER	TAPA
22	15896411	1	DADO	ECROU	MUTTER	NUT	TUERCA

ALTERNATORE

Alternateur
Drehstrom-Lichtmaschine

Alternator
Alternador

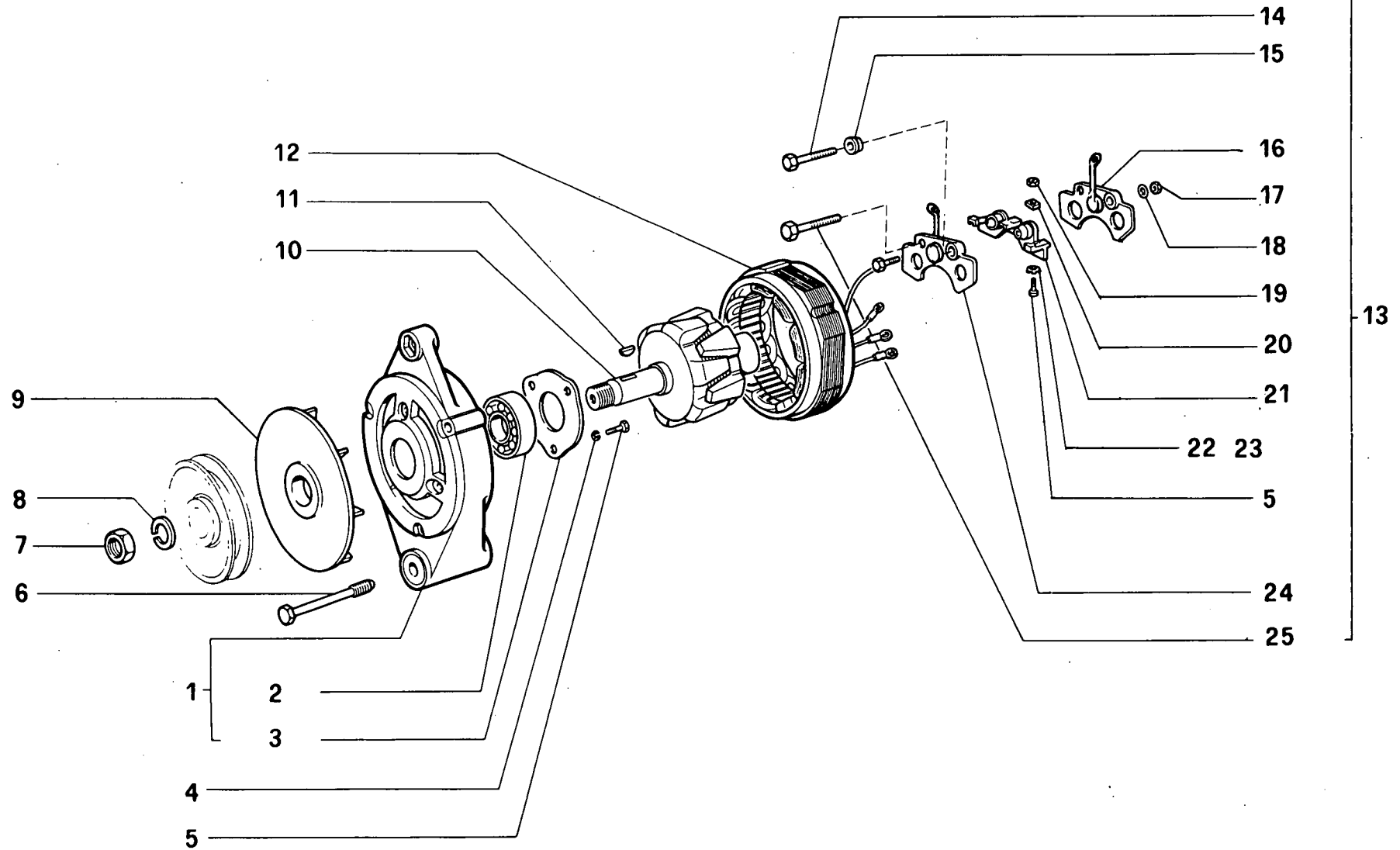

C80/50

ALTERNATORE

80.04/02

(09-1981)

FIG	N. ORDINAZIONE	QTA	DENOMINAZIONE	DESIGNATION	BENENNUNG	DESCRIPTION	DENOMINACIONES
	4988636	1	ALTERNATORE COMPL.	ALTERNATEUR	DREHSTROMLICHTMA-	ALTERNATOR	ALTERNADOR
1	4988662	1	SUPPORTO COMPL.	SUPPORT	LAGER	SUPPORT	SOPORTE
2	4988664	1	CUSCINETTO	ROULEMENT	LAGER	BEARING	RODAMIENTO
3	4988663	1	COPERCHIO	COUVERCLE	DECKEL	COVER	TAPA
4	11195371	3	ROSETTA DI SICUREZZA	RONDELLE FREIN	SICHERUNGSRING	LOCKWASHER	ARANDELA DE FRENO
5	4988654	6	VITE	VIS	SCHRAUBE	SCREW	TORNILLO
6	4988639	1	VITE	VIS	SCHRAUBE	SCREW	TORNILLO
7	4988697	1	DADO	ECROU	MUTTER	NUT	TUERCA
8	10572171	1	ROSETTA DI SICUREZZA	RONDELLE FREIN	SICHERUNGSRING	LOCKWASHER	ARANDELA DE FRENO
9	4988661	1	VENTOLA	SOUFFLERIE	GEBLAESE	BLOWER	VENTILADOR
10	4988677	1	ROTORE	ROTOR	LAUFER	ROTOR	ROTOR
11	10206320	1	LINGUETTA	LINGUET	SCHEIBENFEDER	KEY	CHAVETA
12	4988666	1	STATORE	STATOR	STATOR	STATOR	ESTATOR
13	4988640	1	PIASTRA COMPL.	PLAQUE	PLATTE	PLATE	PLACA
14	4988655	1	VITE	VIS	SCHRAUBE	SCREW	TORNILLO
15	4988644	1	BOCCOLA	DOUILLE	BUECHSE	BUSH	CASQUILLO
16	4988646	1	PIASTRINA	PLAQUETTE	PLAETTCHEN	PLATE	PLACA
17	4988652	1	DADO	ECROU	MUTTER	NUT	TUERCA
18	4988653	2	ROSETTA	RONDELLE	SCHEIBE	WASHER	ARENDELA
19	10794011	3	DADO	ECROU	MUTTER	NUT	TUERCA
20	4988641	3	DADO	ECROU	MUTTER	NUT	TUERCA
21	4988643	1	SUPPORTO	SUPPORT	LAGER	SUPPORT	SOPORTE
22	4988642	2	PIASTRINA	PLAQUETTE	PLAETTCHEN	PLATE	PLACA
23	4988645	1	PIASTRINA	PLAQUETTE	PLAETTCHEN	PLATE	PLACA
24	4988649	1	PIASTRINA	PLAQUETTE	PLAETTCHEN	PLATE	PLACA
25	4988656	1	VITE	VIS	SCHRAUBE	SCREW	TORNILLO

ALTERNATORE

Alternateur
Drehstrom-Lichtmaschine

Alternator
Alternador

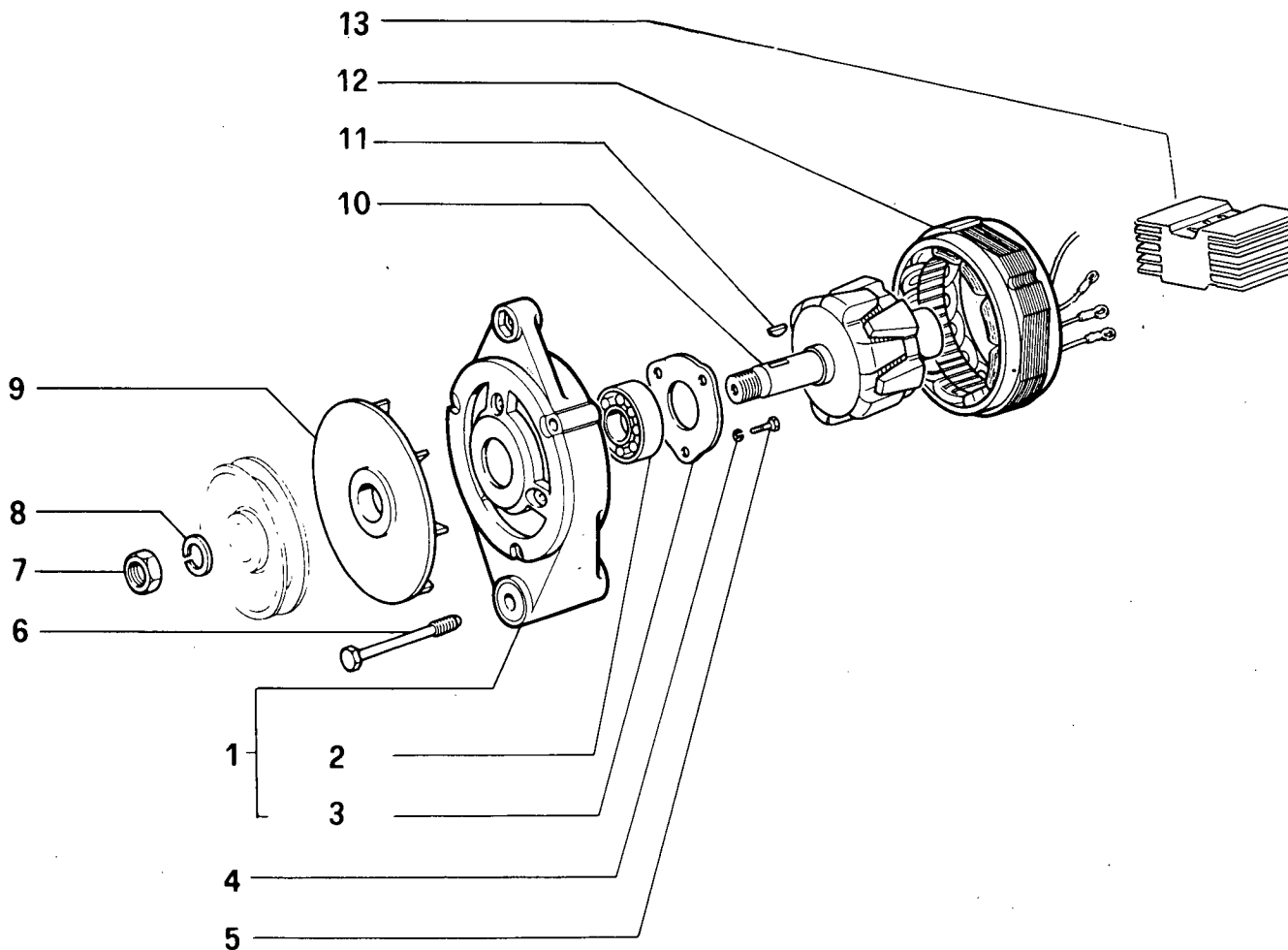

C80/50

ALTERNATORE

80.04/02

(09-1981)

FIG	N. ORDINAZIONE	QTA	DENOMINAZIONE	DESIGNATION	BENENNUNG	DESCRIPTION	DENOMINACIONES
	4753104	1	ALTERNATORE COMPL.	ALTERNATEUR	DREHSTROMLICHTMA-	ALTERNATOR	ALTERNADOR
1	4988662	1	SUPPORTO COMPL.	SUPPORT	LAGER	SUPPORT	SOPORTE
2	4988664	1	CUSCINETTO	ROULEMENT	LAGER	BEARING	RODAMIENTO
3	4988663	1	COPERCHIO	COUVERCLE	DECKEL	COVER	TAPA
4	11195371	3	ROSETTA DI SICUREZZA	RONDELLE FREIN	SICHERUNGSRING	LOCKWASHER	ARANDELA DE FRENO
5	4988654	6	VITE	VIS	SCHRAUBE	SCREW	TORNILLO
6	4988639	1	VITE	VIS	SCHRAUBE	SCREW	TORNILLO
7	4988697	1	DADO	ECROU	MUTTER	NUT	TUERCA
8	10572171	1	ROSETTA DI SICUREZZA	RONDELLE FREIN	SICHERUNGSRING	LOCKWASHER	ARANDELA DE FRENO
9	4988661	1	VENTOLA	SOUFFLERIE	GEBLAESE	BLOWER	VENTILADOR
10	4988677	1	ROTORE	ROTOR	LAUFER	ROTOR	ROTOR
11	10206320	1	LINGUETTA	LINGUET	SCHEIBENFEDER	KEY	CHAVETA
12	4733831	1	STATORE	STATOR	STATOR	STATOR	ESTATOR
13	4733830	1	PIASTRA COMPL.	PLAQUE	PLATTE	PLATE	PLACA

ALTERNATORE

Alternateur
Drehstrom-Lichtmaschine

Alternator
Alternador

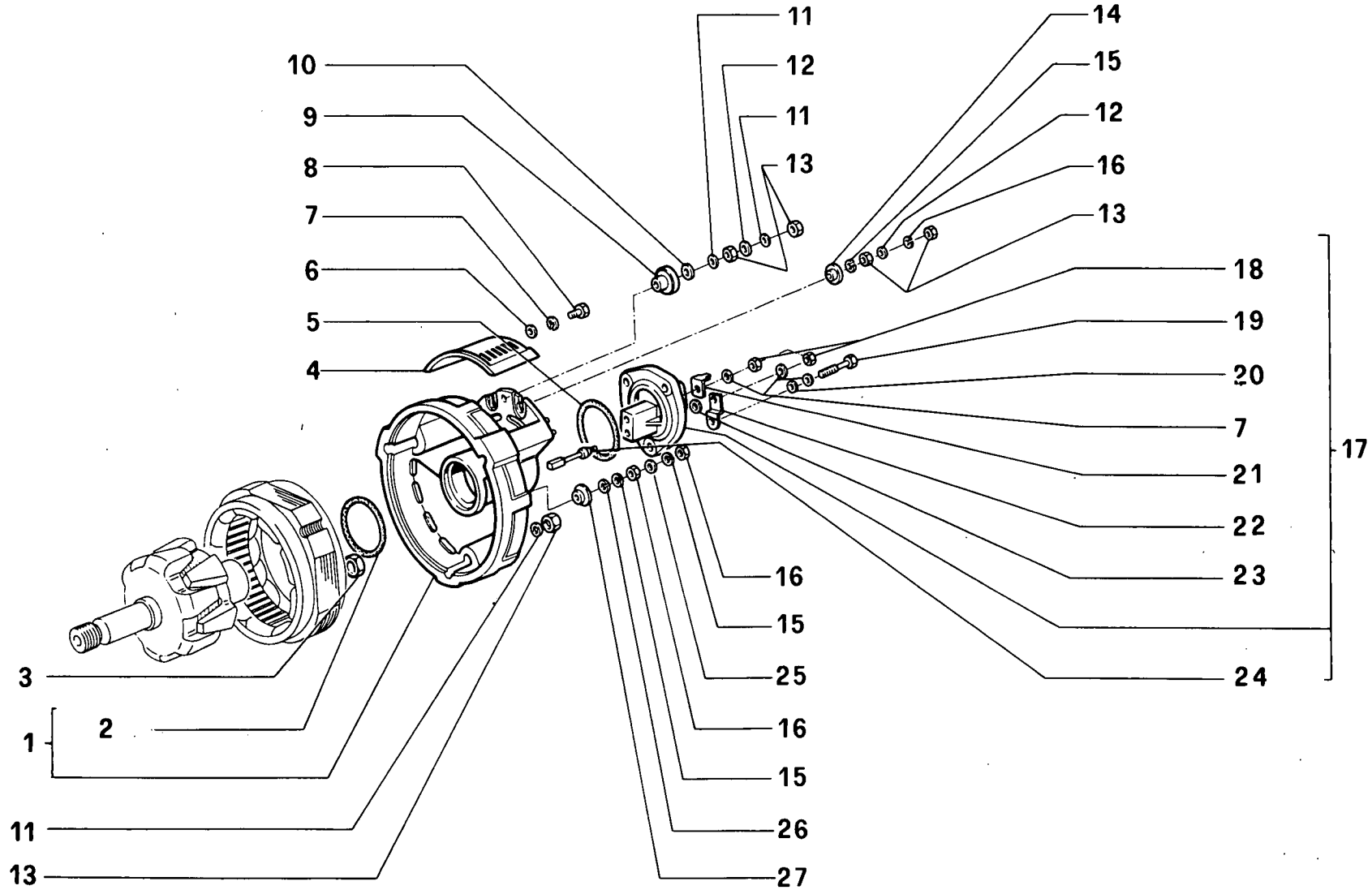

FIG	N. ORDINAZIONE	QTA	DENOMINAZIONE	DESIGNATION	BENENNUNG	DESCRIPTION	DENOMINACIONES
1	4988667	1	SUPPORTO COMPL.	SUPPORT	LAGER	SUPPORT	SOPORTE
2	14458780	1	ANELLO OR	BAGUE TORIQUE	O-RING	O-SEAL	ANILLO O.
3	4988660	1	ISOLANTE	ISOLANT	ISOLIERUNG	INSULATOR	AISLADOR
4	4988658	1	RIPARO	PROTECTION	ABDECKUNG	PROTECTION	DEFENSA
5	4988673	1	ANELLO DI TENUTA	JOINT D'ETANCHEITE	DICHTRING	SEAL	JUNTA HERMETICA
6	4988683	1	ROSETTA	RONDELLE	SCHEIBE	WASHER	ARENDELA
7	11195371	6	ROSETTA DI SICUREZZA	RONDELLE FREIN	SICHERUNGSRING	LOCKWASHER	ARANDELA DE FRENO
8	4988696	1	VITE	VIS	SCHRAUBE	SCREW	TORNILLO
9	4988637	1	BOCCOLA	DOUILLE	BUECHSE	BUSH	CASQUILLO
10	4988686	1	ROSETTA	RONDELLE	SCHEIBE	WASHER	ARENDELA
11	10516471	5	ROSETTA DI SICUREZZA	RONDELLE FREIN	SICHERUNGSRING	LOCKWASHER	ARANDELA DE FRENO
12	4988687	2	ROSETTA	RONDELLE	SCHEIBE	WASHER	ARENDELA
13	15896211	5	DADO	ECROU	MUTTER	NUT	TUERCA
14	4988638	1	BOCCOLA	DOUILLE	BUECHSE	BUSH	CASQUILLO
15	11195471	4	ROSETTA DI SICUREZZA	RONDELLE FREIN	SICHERUNGSRING	LOCKWASHER	ARANDELA DE FRENO
16	15896411	4	DADO	ECROU	MUTTER	NUT	TUERCA
17	4988670	1	PORTASPAZZOLA COMPL.	PORTE-BALAI	BUERSTENTRAEGER	BRUSH HOLDER	PORTAESCOBILLA
18	10794011	2	DADO	ECROU	MUTTER	NUT	TUERCA
19	10375101	3	VITE	VIS	SCHRAUBE	SCREW	TORNILLO
20	4988678	2	ROSETTA	RONDELLE	SCHEIBE	WASHER	ARENDELA
21	4988675	1	PIASTRINA	PLAQUETTE	PLAETTCHEN	PLATE	PLACA
22	4988672	1	PIASTRINA	PLAQUETTE	PLAETTCHEN	PLATE	PLACA
23	4988674	2	ANELLO DI TENUTA	JOINT D'ETANCHEITE	DICHTRING	SEAL	JUNTA HERMETICA
24	4988676	2	SPAZZOLA	BALAI	KOHLLENBUERSTE	BRUSH	ESCOBILLA
25	4988653	2	ROSETTA	RONDELLE	SCHEIBE	WASHER	ARENDELA
26	4988688	3	ROSETTA	RONDELLE	SCHEIBE	WASHER	ARENDELA
27	4988659	1	TERMINALE	BORNE	LABELSCHUH	TERMINAL	TERMINAL

CB50

01.02.03

MOTORINO DI AVVIAMENTO (MARELLI)

Démarrreur
Anlasser

Starter motor
Motor de arranque

80.4/4

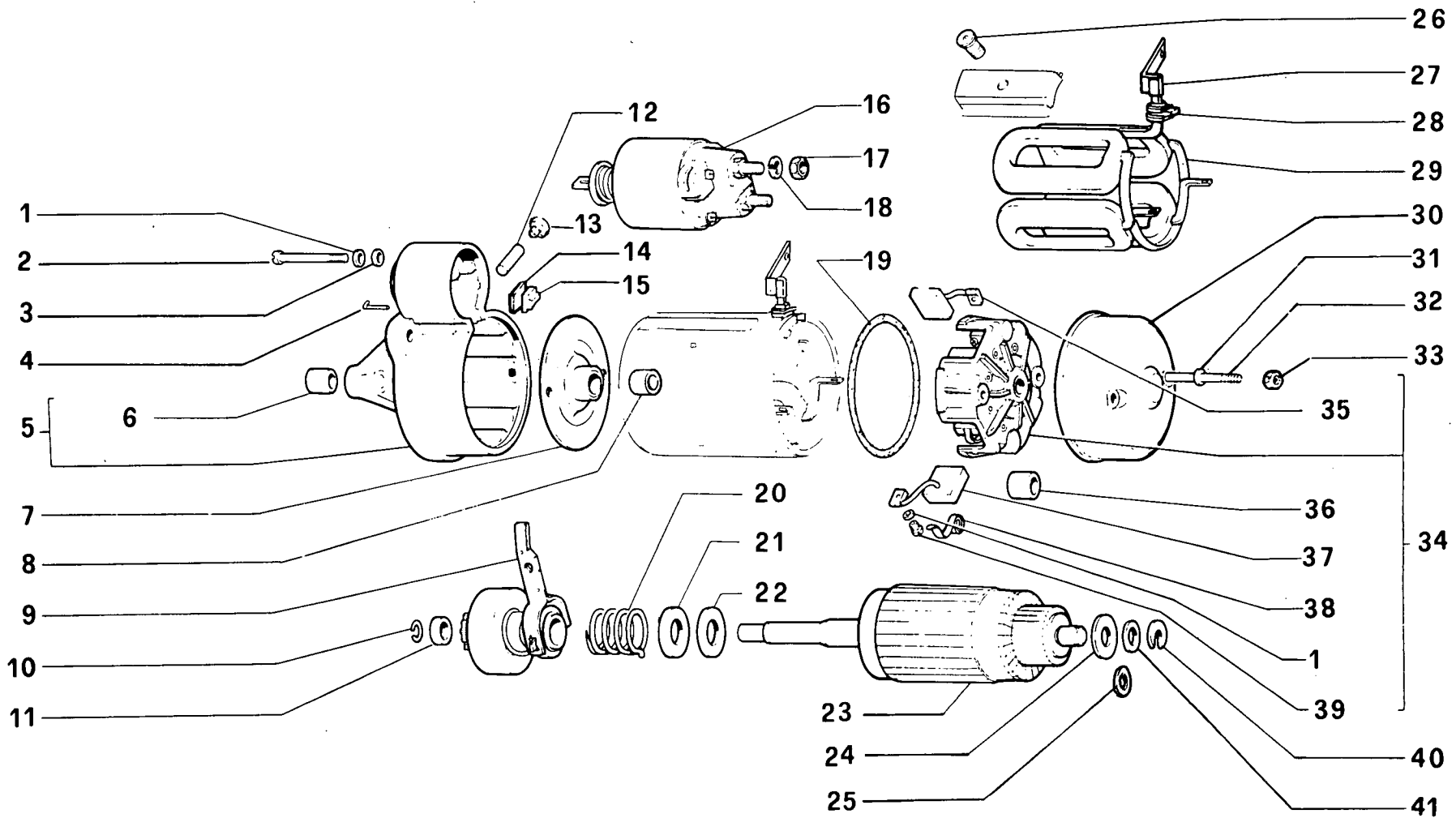

FIG	N. ORDINAZIONE	QTA	DENOMINAZIONE	DESIGNATION	BENENNUNG	DESCRIPTION	DENOMINACIONES
	5111319	1	MOTORINO D'AVVIAMENTO	DEMARREUR	ANLASSER	STARTER MOTOR	MOTOR DE ARRANQUE
1	11195471	7	ROSETTA DI SICUREZZA	RONDELLE FREIN	SICHERUNGSRING	LOCKWASHER	ARANDELA DE FRENO
2	9927813	3	VITE	VIS	SCHRAUBE	SCREW	TORNILLO
3	10519301	3	ROSETTA PIANA	RONDELLE	SCHEIBE	WASHER	ARANDELA
4	9927806	1	SPINA	GOUPILLE	STIFT	PIN	PASADOR
5	9957964	1	SUPPORTO ANTERIORE COMPL.	SUPPORT	LAGER	SUPPORT	SOPORTE
6	9927787	1	BOCCOLA	DOUILLE	BUECHSE	BUSH	CASQUILLO
7	9927795	1	SUPPORTO	SUPPORT	LAGER	SUPPORT	SOPORTE
8	9927796	1	BOCCOLA	DOUILLE	BUECHSE	BUSH	CASQUILLO
9	9957965	1	INNESTO AVVIAMENTO	ENCLENCHEMENT	RITZELTRIEB	DRIVE UNIT	ACOPLAMIENTO
10	9927797	1	ANELLO DI SICUREZZA	ARRETOIR	SICHERUNGSRING	LOCKRING	ANILLO DE FRENO
11	9927798	1	ANELLO DI RITEGNO	ARRETOIR	HALTERING	RETAINER	RETENEDOR
12	9927799	1	PERNO	AXE	BOLZEN	PIN	EJE
13	9956559	1	TAPPO	BOUCHON	STOPFEN	PLUG	TAPON
14	9957709	1	PIASTRINA	PLAQUETTE	PLAETTCHEN	PLATE	PLACA
15	9957710	1	TASSELLO ELASTICO	TAMPON	GUMMISTUECK	PAD	ALMOHADILLA
16	9957705	1	ELETTROMAGNETE	ELECTRO	MAGNETSCHALTER	SOLENOID	MAGNETO
17	9934288	2	DADO	ECROU	MUTTER	NUT	TUERCA
18	9902481	2	ROSETTA DI SICUREZZA	RONDELLE FREIN	SICHERUNGSRING	LOCKWASHER	ARANDELA DE FRENO
19	9927815	1	ANELLO DI GOMMA	BAGUE CAOUTCHOUC	GUMMIRING	RUBBER RING	GUARNICION DE CAUCHO
20	9927800	1	MOLLA	RESSORT	FEDER	SPRING	RESORTE
21	9927801	1	SCODELLINO	CUVETTE	TELLERSCHEIBE	CUP	PLATILLO
22	9927802	1	ROSETTA ISOLANTE	RONDELLE ISOLANTE	ISOLIERSCHEIBE	INSULATOR	ARANDELA AISLANTE
23	9956550	1	INDOTTO 40I	INDUIT	ANKER	ARMATURE	INDUCIDO
24	9909440	1	ROSETTA PIANA	RONDELLE	SCHEIBE	WASHER	ARANDELA
25	9933234	1	ROSETTA PIANA	RONDELLE	SCHEIBE	WASHER	ARANDELA
26	9909452	4	VITE	VIS	SCHRAUBE	SCREW	TORNILLO
27	9956557	1	CONNESSIONE	CONNEXION	LEITUNG	CONNECTION	CABLE
28	9928452	1	TASSELLO	TAMPON	BEILAGE	PAD	TACO
29	9957574	1	AVVOLGIMENTO	ENROULEMENT	WICKLUNG	WINDING	BOBINA
30	9956554	1	CALOTTA	CALOTTE	KAPPE	CAP	TAPA
31	13550201	2	ROSETTA DI SICUREZZA	RONDELLE FREIN	SICHERUNGSRING	LOCKWASHER	ARANDELA DE FRENO
32	9956558	2	PRIGIONIERO	GOUJON	STIFTSCHRAUBE	STUD	ESPARRAGO
33	12574211	2	DADO	ECROU	MUTTER	NUT	TUERCA

CEB.50

01 02 03

MOTORINO DI AVVIAMENTO (MARELLI)

Démarrreur
Anlasser

Starter motor
Motor de arranque

80.4/4

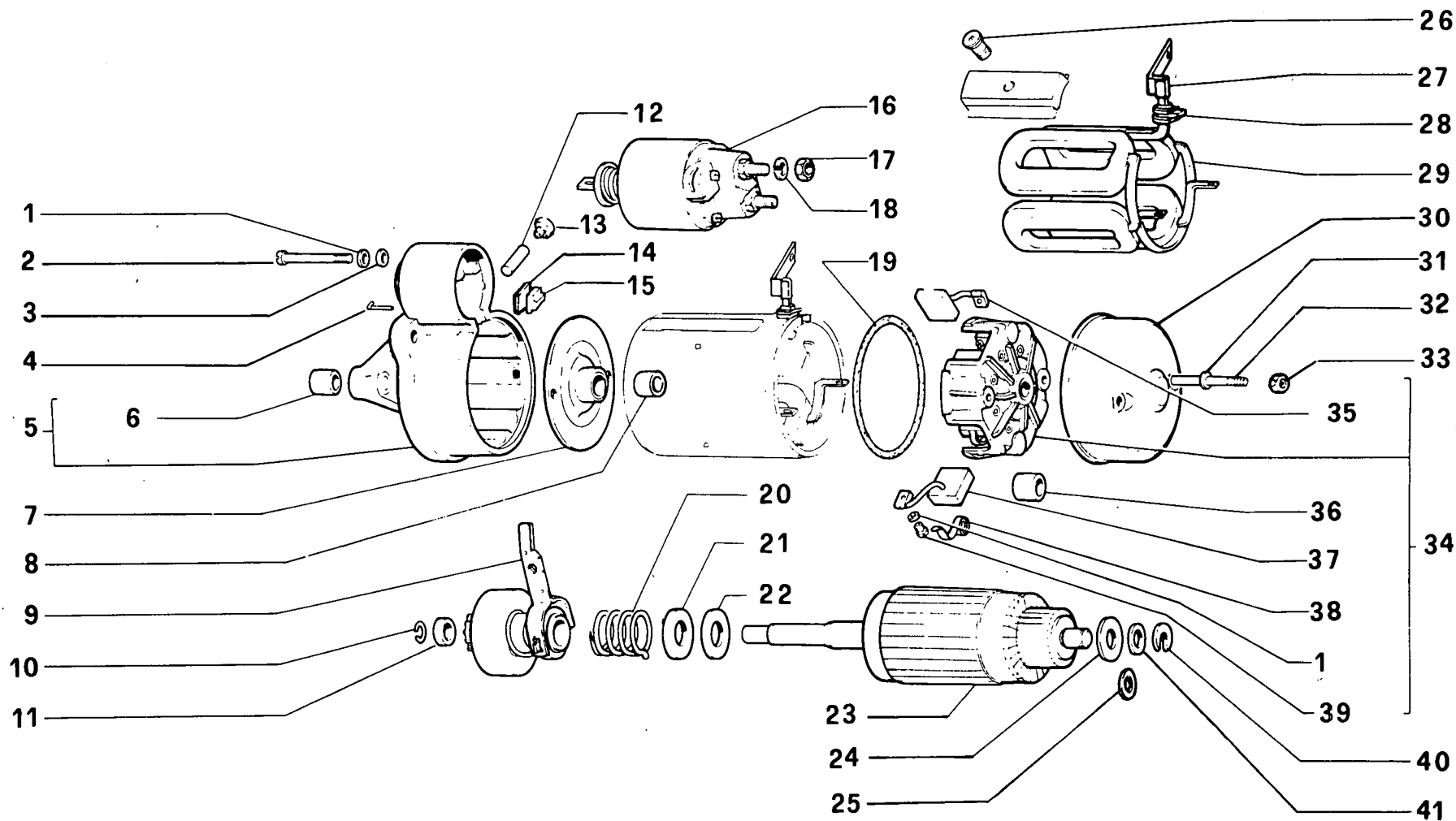

C80/50

MOTORINO D'AVVIAMENTO MARELLI

80.04/04

(09-1981)

FIG	N. ORDINAZIONE	QTA	DENOMINAZIONE	DESIGNATION	BENENNUNG	DESCRIPTION	DENOMINACIONES
34	9956553	1	SUPPORTO COMPL.	SUPPORT	LAGER	SUPPORT	SOPORTE
35	9956552	2	SPAZZOLA	BALAI	KOHLLENBUERSTE	BRUSH	ESCOBILLA
36	9927789	1	BOCCOLA	DOUILLE	BUECHSE	BUSH	CASQUILLO
37	9956556	2	SPAZZOLA	BALAI	KOHLLENBUERSTE	BRUSH	ESCOBILLA
38	9956555	4	MOLLA	RESSORT	FEDER	SPRING	RESORTE
39	9957913	4	VITE	VIS	SCHRAUBE	SCREW	TORNILLO
40	9933229	1	ROSETTA DI SICUREZZA	RONDELLE FREIN	SICHERUNGSRING	LOCKWASHER	ARANDELA DE FRENO
41	9909170	1	SPESSORE DI REGISTRO	CALE D'EPAISSEUR	DISTANZSCHEIBE	SHIM	SUPLEMENTO

CBQ.50

01 02 03

IMPIANTO ELETTRICO

Installation électrique
Elektroanlage

Electric sistem
Sistema eléctrico

80.5/1

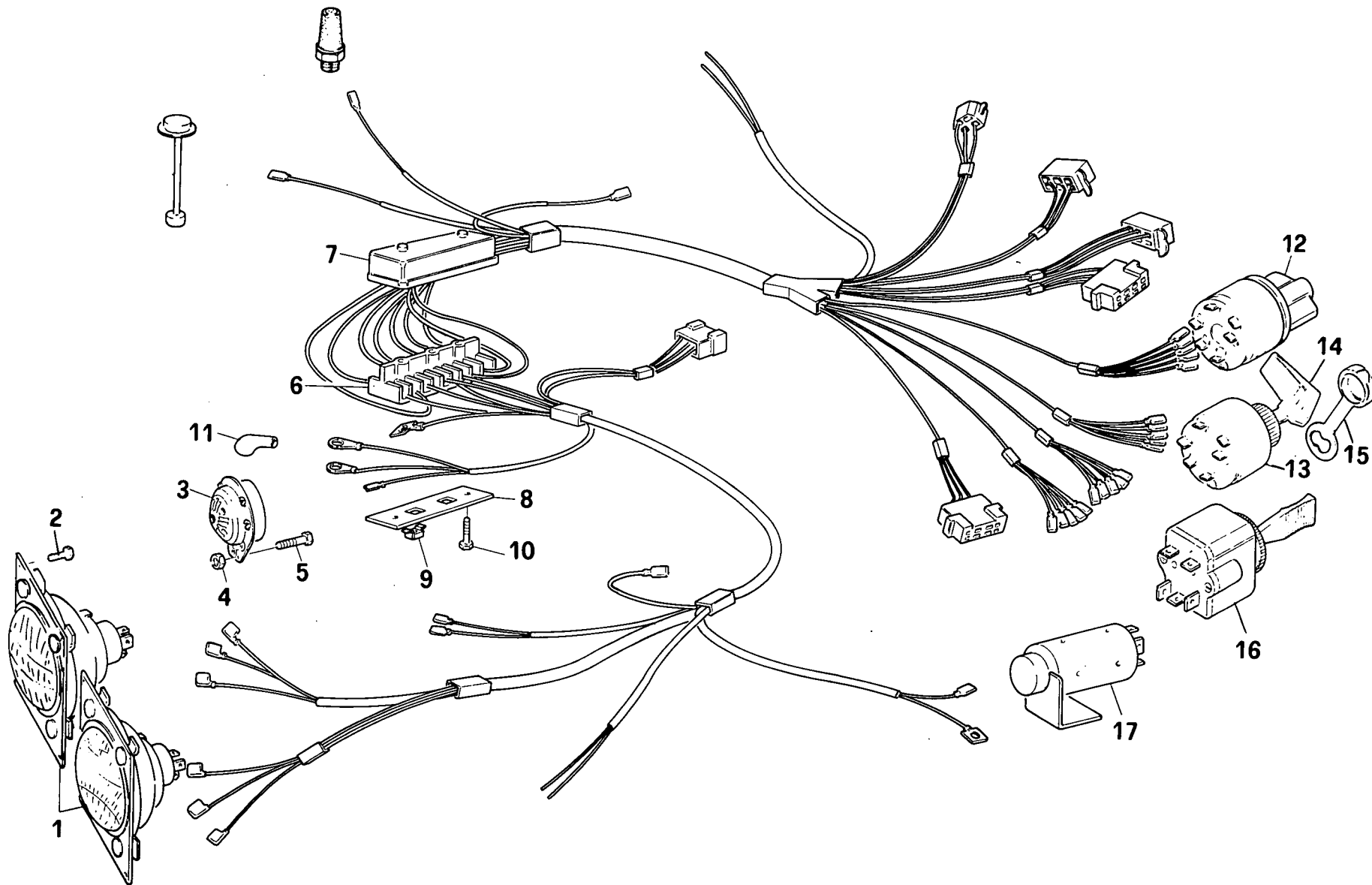

C80/50

IMPIANTO ELETTRICO ANTERIORE

80.05/01

(09-1981)

FIG	N. ORDINAZIONE	QTA	DENOMINAZIONE	DESIGNATION	BENENNUNG	DESCRIPTION	DENOMINACIONES
	44902206	1	IMPIANTO ELETTRICO ANTERIORE COMPL. D.	INSTALLATION ELECTRIQUE AVANT	VORDERELECRO-ANLAGE	FRONT ELECTRIC SYSTEM	SISTEMA ELECTRICO DELANTERO
	44901531	1	IMPIANTO ELETTRICO ANTERIORE COMPL. F.	INSTALLATION ELECTRIQUE AVANT	VORDERELECRO-ANLAGE	FRONT ELECTRIC SYSTEM	SISTEMA ELECTRICO DELANTERO
1	44901876	2	PROIETTORE	PROJECTEUR	SCHEINWERFER	HEADLAMP	PROYECTOR
2	13276011	8	VITE	VIS	SCHRAUBE	SCREW	TORNILLO
3	44900990	1	AVVISATORE ACUSTICO	AVERTISSEUR	HORN	HORN	BOCINA
4	16100811	1	DADO	ECROU	MUTTER	NUT	TUERCA
5	16043421	1	VITE	VIS	SCHRAUBE	SCREW	TORNILLO
6	44981084	1	SCATOLA VALVOLE FUSIB. D.	BOITE A FUSIBLES	SICHERUNGSDOSE	FUSE BOX	CAJA DE FUSIBLES
7	44981000	1	COPERCHIO D.	COUVERCLE	DECKEL	COVER	TAPA
8	44901788	1	SUPPORTO D.	SUPPORT	LAGER	SUPPORT	SOPORTE
9	15896211	2	DADO D.	ECROU	MUTTER	NUT	TUERCA
10	13274611	2	VITE D.	VIS	SCHRAUBE	SCREW	TORNILLO
11	44980901	1	CAPPUCCIO	CAPUCHON	STAUBSCHUTZKAPPE	BOOT	CAPUCHON
12	44901794	1	INTERRUTTORE LUCE	INTERRUPTEUR D'ECL	LICHTSCHALTER	LIGHT SWITCH	CONMUTAD. ALUMBRADO
13	44901424	1	INTERRUTTORE	INTERRUPTEUR	SCHALTER	SWITCH	INTERRUPTOR
14	44900845	1	CHIAVE	CLE	SCHLUESSEL	WRENCH	LLAVE
15	44901870	1	TAPPO	BOUCHON	STOPFEN	PLUG	TAPON
16	44901503	1	INDICATORE DI DIREZIONE	INDICATEUR DE DIRECTION	RICHTUNGSANZEIGER	DIRECTION INDICATION	INDICADOR DE DIRECCION
17	4954117	1	LAMPEGGIATORE	CLIGNOTANT	BLINKGEBER	FLASHER	RELE DE INTERMITENCIA

IMPIANTO ELETTRICO POSTERIORE

Installation électrique arrière
Elektroanlage - hinten

Rear electric sistem
Sistema eléctrico posterior

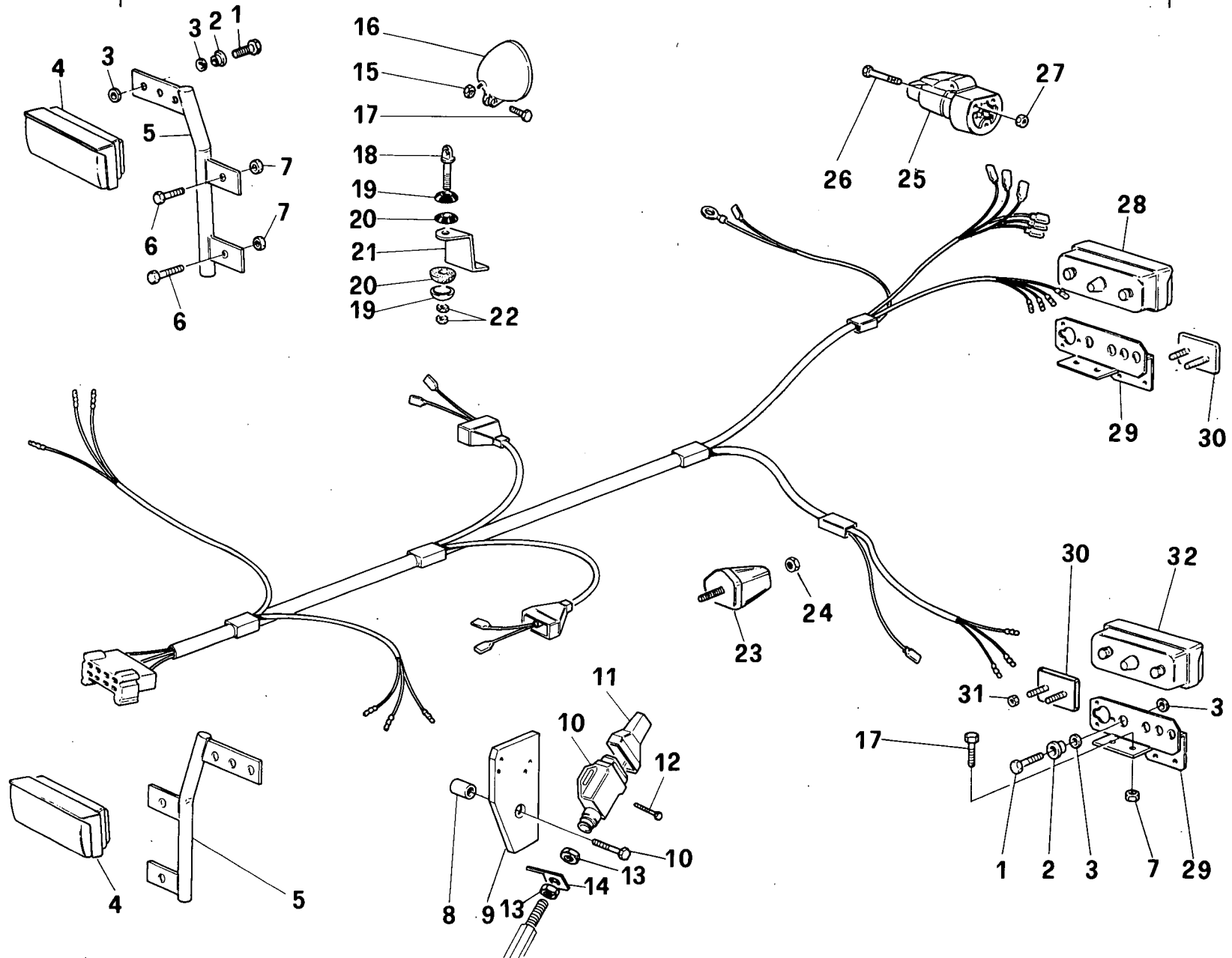

C80/50

IMPIANTO ELETTRICO POSTERIORE

80.05/02

(09-1981)

FIG	N. ORDINAZIONE	QTA	DENOMINAZIONE	DESIGNATION	BENENNUNG	DESCRIPTION	DENOMINACIONES
	5120324	1	IMPIANTO ELETTRICO POSTERIORE	INSTALLATION ELECTRIQUE ARRIERE	ELEKTROANLAGE-HINTEN	REAR ELECTRIC SISTEM	SISTEMA ELECTRICO POSTERIOR
1	13274611	4	VITE	VIS	SCHRAUBE	SCREW	TORNILLO
2	44901784	8	FLANGIA	BRIDE	FLANSCH	FLANGE	BRIDA
3	5119917	16	ANELLO DI GOMMA	BAGUE CAOUTCHOUC	GUMMIRING	RUBBER RING	GUARNICION DE CAUCHO
4	5119843	2	FANALE ANTERIORE	LANTERNE AV.	VORDERE LEUCHTE	FRONT LAMP	LAMPARA ANTERIOR
5	44901513	2	SUPPORTO	SUPPORT	LAGER	SUPPORT	SOPORTE
6	15970921	6	VITE	VIS	SCHRAUBE	SCREW	TORNILLO
7	5120362	2	DISTANZIALE.	ENTRETOISE	ABSTANDSTUECK	SPACER	SEPARADOR
9	44901785	2	PIASTRINA	PLAQUETTE	PLAETTCHEN	PLATE	PLACA
10	44901831	1	INTERRUTTORE STOP	INTERRUPTEUR	SCHALTER	SWITCH	INTERRUPTOR
11	44981083	1	CAPPUCCIO	CAPUCHON	STAUBSCHUTZKAPPE	BOOT	CAPUCHON
12	13272011	4	VITE	VIS	SCHRAUBE	SCREW	TORNILLO
13	13103611	2	DADO	ECROU	MUTTER	NUT	TUERCA
14	44901787	2	PIASTRINA	PLAQUETTE.	PLAETTCHEN	PLATE	PLACA
15	12574511	1	DADO	ECROU	MUTTER	NUT	TUERCA
16	5011696	1	PROIETTORE ORIENTABILE	PHARE-CHERCHEUR	SUCHSCHEINWERFER	SPOTLIGHT	FARO ENFOQUE MOV.
17	15970721	5	VITE	VIS	SCHRAUBE	SCREW	TORNILLO
18	566337	1	PERNO	AXE	BOLZEN	PIN	EJE
19	566340	2	SCODELLINO	CUVETTE	TELLERSCHEIBE	CUP	PLATILLO
20	566339	2	TASSELLO ELASTICO	TAMPON	GUMMISTUECK	PAD	ALMOHADILLA
21	4951135	1	SUPPORTO	SUPPORT	LAGER	SUPPORT	SOPORTE
22	10791011	2	DADO	ECROU	MUTTER	NUT	TUERCA
23	4222234	1	FANALE TARGA	FEU DE PLAQUE	NUMMERNSCHILDLEUC.	NUMBER PLATE LAMP	LAMPARA DE MATRICULA
24	15896211	2	DADO	ECROU	MUTTER	NUT	TUERCA
25	44901803	1	PRESA DI CORRENTE 7 POLI	PRISE DE COURANT	STECKDOSE	RECEPTACLE	ENCHUFE DE CORRIENTE
26	13274911	3	VITE	VIS	SCHRAUBE	SCREW	TORNILLO
27	15896411	3	DADO	ECROU	MUTTER	NUT	TUERCA
28	5119845	1	FANALE POSTERIORE DX	LANTERNE AR.	HINTERE LEUCHTE	TAIL LAMP	LAMPARA POSTERIOR
29	44901783	2	SUPPORTO	SUPPORT	LAGER	SUPPORT	SOPORTE
30	5109513	2	CATADIOTTRO	CATADIOPTRE	RUECKSTRAHLER	REFLEX/REFLECTOR	CATAFAROS
31	15896411	4	DADO	ECROU	MUTTER	NUT	TUERCA

IMPIANTO ELETTRICO POSTERIORE

Installation électrique arrière
Elektroanlage - hinten

Rear electric sistem
Sistema eléctrico posterior

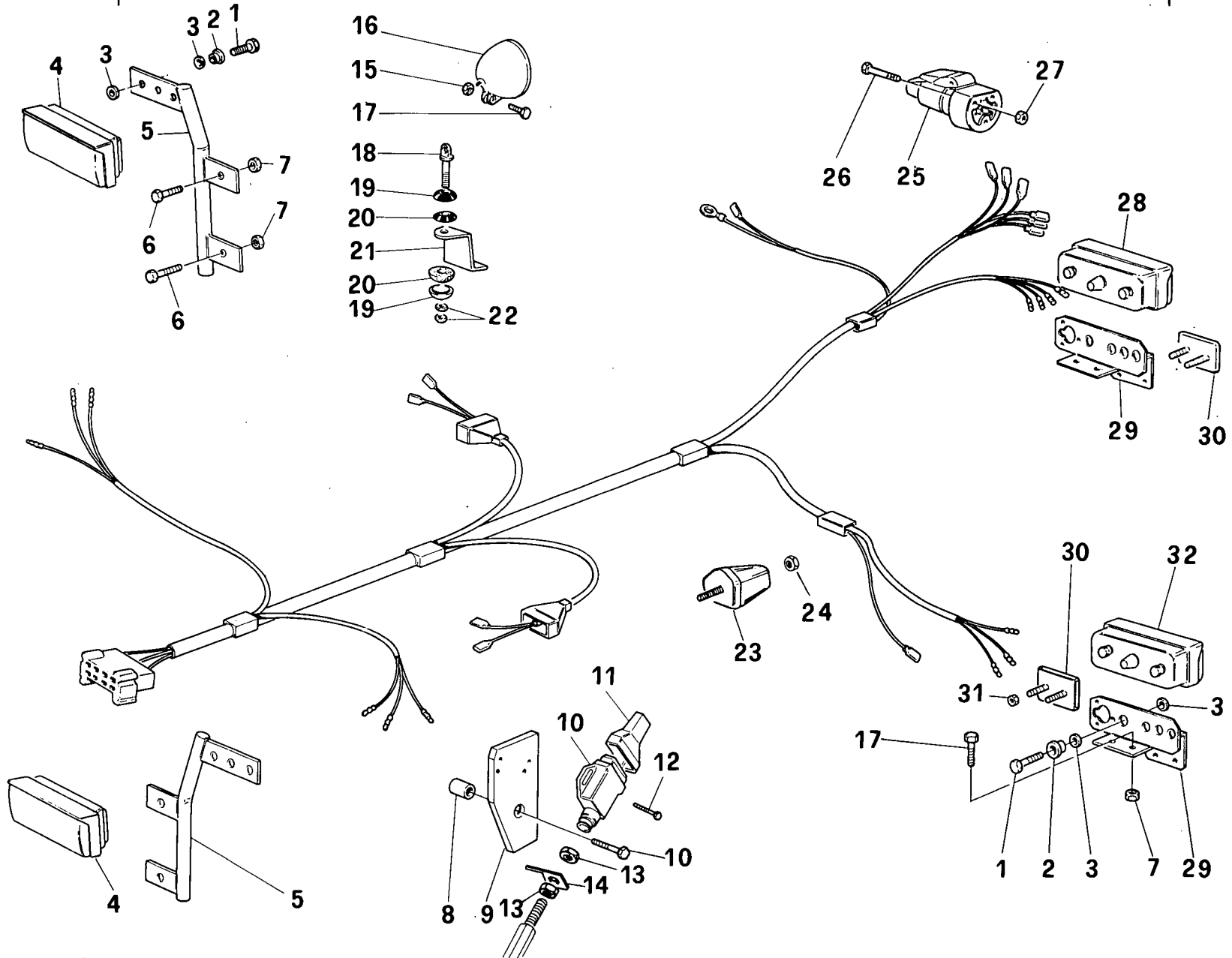

C80/50

IMPIANTO ELETTRICO POSTERIORE

80.05/02

(09-1981)

FIG	N. ORDINAZIONE	QTA	DENOMINAZIONE	DESIGNATION	BENENNUNG	DESCRIPTION	DENOMINACIONES
32	5119847	1	FANALE POSTERIORE SX	LANTERNE AR.	HINTERE LEUCHTE	TAIL LAMP	LAMPARA POSTERIOR

CEB 50

01 02 03

PROIETTORI

Projecteurs
Scheinwerfer

Spot lamps
Proyectoros

80.5/3

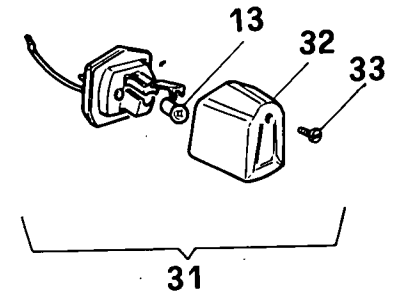
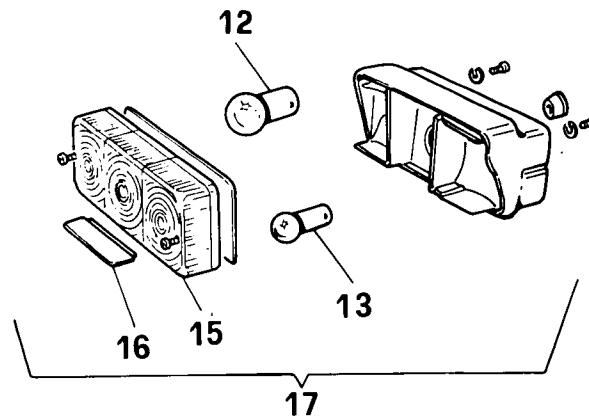
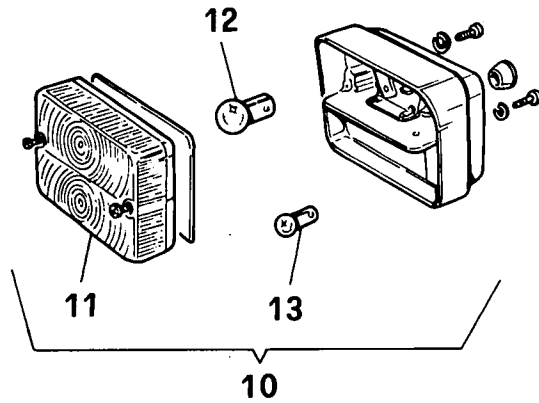
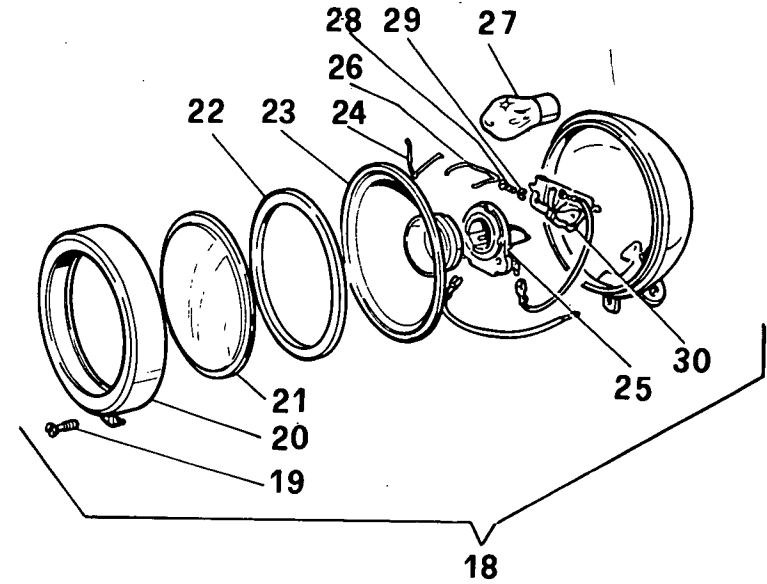
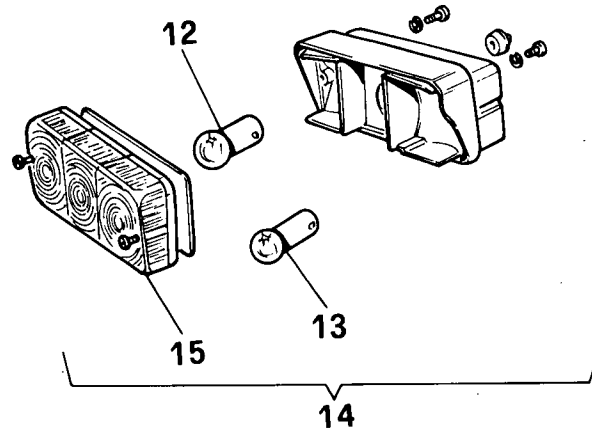
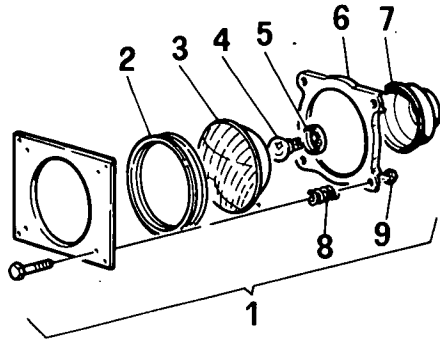

C80/50

PROIETTORI

80.05/03

(09-1981)

FIG	N. ORDINAZIONE	QTA	DENOMINAZIONE	DESIGNATION	BENENNUNG	DESCRIPTION	DENOMINACIONES
1	44901876	2	PROIETTORE ANT.	PROJECTEUR	SCHEINWERFER	HEADLAMP	PROYECTOR
2	9929842	1	GUARNIZIONE	GARNITURE	DICHTUNG	GASKET	JUNTA
3	9929838	1	GRUPPO OTTICO	GROUPE OPTIQUE	EINSATZ	LENS/REFLECTOR UNIT	GRUPO OPTICO
4	14147590	1	LAMPADA	LAMPE	LAMPE	BULB	BOMBILLA
5	9929839	1	SCODELLINO	CUVETTE	TELLERSCHEIBE	CUP	PLATILLO
6	9929843	1	SUPPORTO	SUPPORT	LAGER	SUPPORT	SOPORTE
7	44901385	1	CAPPUCCIO	CAPUCHON	STAUBSCHUTZKAPPE	BOOT	CAPUCHON
8	9929841	4	MOLLA	RESSORT	FEDER	SPRING	RESORTE
9	12574211	4	DADO	ECROU	MUTTER	NUT	TUERCA
10	5119843	2	FANALE ANTERIORE	LANTERNE AV.	VORDERE LEUCHE	FRONT LAMP	LAMPARA ANTERIOR
11	44981085	1	TRASPARENTE	TRANSPARENT	LICHTSCHEIBE	LENS	TAPA TRANSLUCIDA
12	14148190	1	LAMPADA	LAMPE	LAMPE	BULB	BOMBILLA
13	10857790	2	LAMPADA	LAMPE	LAMPE	BULB	BOMBILLA
14	5119845	1	FANALE POSTERIORE DX	LANTERNE AR.	HINTERE LEUCHE	TAIL LAMP	LAMPARA POSTERIOR
15	44981087	1	TRASPARENTE	TRANSPARENT	LICHTSCHEIBE	LENS	TAPA TRANSLUCIDA
16	44981086	1	TRASPARENTE INF.	TRANSPARENT	LICHTSCHEIBE	LENS	TAPA TRANSLUCIDA
17	5119847	1	FANALE POSTERIORE SX	LANTERNE AR.	HINTERE LEUCHE	TAIL LAMP	LAMPARA POSTERIOR
18	5011696	1	PROIETTORE ORIENTABILE	PHARE-CHERCHEUR	SUCHSCHEINWERFER	SPOTLIGHT	FARO ENFOQUE MOV.
19	9907163	1	VITE DI REGISTRO	VIS DE REGLAGE	EINSTELLSCHRAUBE	ADJUSTING SCREW	TORNILLO GRADUACION
20	9927294	1	CALOTTA PROIETTORE	CORPS DE PHARE	SCHEINWERFERTOPF	HEADLAMP CUP	CUBETA FARO
21	9927290	1	TRASPARENTE	TRANSPARENT	LICHTSCHEIBE	LENS	TAPA TRANSLUCIDA
22	9928676	1	PARABOLA PROIETTORE	REFLECTEUR	PARABOLSPIEGEL	REFLECTOR	REFLECTOR
24	9927293	6	MOLLETTA	AGRAFE	KLAMMER	CLIP	PINZA
25	9918431	1	PORTALAMPADA	PORTE-LAMPE	LAMPENFASSUNG	BULB HOLDER	PORTALAMPARA
26	9927292	1	MOLLETTA	AGRAFE	KLAMMER	CLIP	PINZA
27	10861290	1	LAMPADA	LAMPE	LAMPE	BULB	BOMBILLA
28	9918434	2	VITE	VIS	SCHRAUBE	SCREW	TORNILLO
29	11195370	2	ROSETTA DI SICUREZZA	RONDELLE FREIN	SICHERUNGSRING	LOCKWASHER	ARANDELA DE FRENO
30	9918433	1	INTERRUTTORE	INTERRUPTEUR	SCHALTER	SWITCH	INTERRUPTOR
31	4222234	1	FANALE TARGA	FEU DE PLAQUE	NUMMERNSCHILDLEUC.	NUMBER PLATE LAMP	LAMPARA DE MATRICULA
32	9927027	1	TRASPARENTE	TRANSPARENT	LICHTSCHEIBE	LENS	TAPA TRANSLUCIDA
33	13273801	1	VITE	VIS	SCHRAUBE	SCREW	TORNILLO

C80.50

01 02 03

SOLLEVATORE IDRAULICO

Relevage hydraulique
Hydraulischer Kraftheber

Hydraulic Lifter
Elevador hidráulico

90.1/1

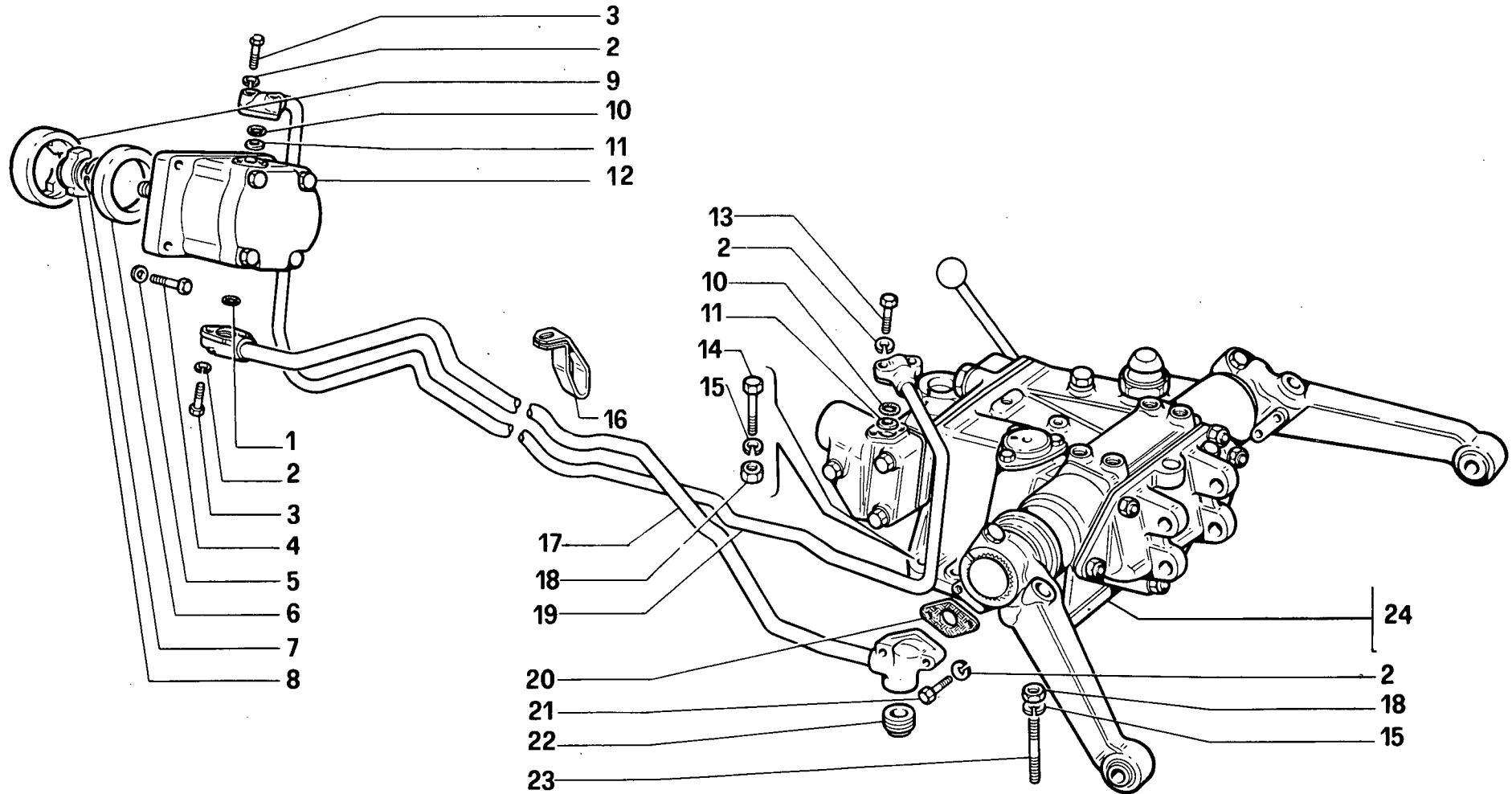

FIG	N. ORDINAZIONE	QTA	DENOMINAZIONE	DESIGNATION	BENENNUNG	DESCRIPTION	DENOMINACIONES
1	14457280	1	ANELLO OR	BAGUE TORIQUE	O-RING	O-SEAL	ANILLO O.
2	10516671	4	ROSETTA DI SICUREZZA	RONDELLE FREIN	SICHERUNGSRING	LOCKWASHER	ARANDELA DE FRENO
3	568292	4	VITE	VIS	SCHRAUBE	SCREW	TORNILLO
4	10903021	4	VITE	VIS	SCHRAUBE	SCREW	TORNILLO
5	10519401	4	ROSETTA DI SICUREZZA	RONDELLE FREIN	SICHERUNGSRING	LOCKWASHER	ARANDELA DE FRENO
6	5118568	1	ANELLO CENTRAGGIO	BAGUE	RING	RING	ANILLO
7	13401476	1	ANELLO DI SICUREZZA	ARRETOIR	SICHERUNGSRING	LOCKRING	ANILLO DE FRENO
8	5118570	1	GIUNTO	ACCOUPLMENT	KUPPLUNG	COUPLING	ARRASTRE
9	5118569	1	MOZZO	MOYEU	NABE	HUB	FUJE
10	14457180	2	ANELLO OR	BAGUE TORIQUE	O-RING	O-SEAL	ANILLO O.
11	44015841	2	ANELLO ANTIESTRUSIONE	BAGUE	RING	RING	ANILLO
12	568162	1	POMPA	POMPE	PUMPE	PUMP	BOMBA
13	16043821	2	VITE	VIS	SCHRAUBE	SCREW	TORNILLO
14	11227021	4	VITE	VIS	SCHRAUBE	SCREW	TORNILLO
15	10517171	6	ROSETTA DI SICUREZZA	RONDELLE FREIN	SICHERUNGSRING	LOCKWASHER	ARANDELA DE FRENO
16	599870	1	STAFFETTA FISSAGGIO	COLLIER	HALTER	RETAINER	ABRAZADERA
17	596654	1	TUBO ASPIRAZIONE	TUYAU ASPIRATION	SAUGROHR	SUCTION PIPE	TUBO ASPIRACION
18	10790411	4	DADO	ECROU	MUTTER	NUT	TUERCA
19	4983317	1	TUBO DI MANDATA	CONDUITE DE REFOUL	DRUCKLEITUNG	DELIVERY LINE	TUBERIA PRESION
20	560057	1	GUARNIZIONE	GARNITURE	DICHTUNG	GASKET	JUNTA
21	16044121	2	VITE	VIS	SCHRAUBE	SCREW	TORNILLO
22	883175	1	TAPPO	BOUCHON	STOPFEN	PLUG	TAPON
23	11798020	2	PRIGIONIERO	GOUJON	STIFTSCHRAUBE	STUD	ESPARRAGO
24	5110247	1	SOLLEVATORE COMPLETO (01-02)	RELEVAGE	KRAFTHEBER	LIFTER	ELEVADOR
24	5121195	1	SOLLEVATORE COMPLETO (03)	RELEVAGE	KRAFTHEBER	LIFTER	ELEVADOR

CEB.50

01 02 03

POMPA

Pompe
Pumpe

Pump
Bomba

90.1/2

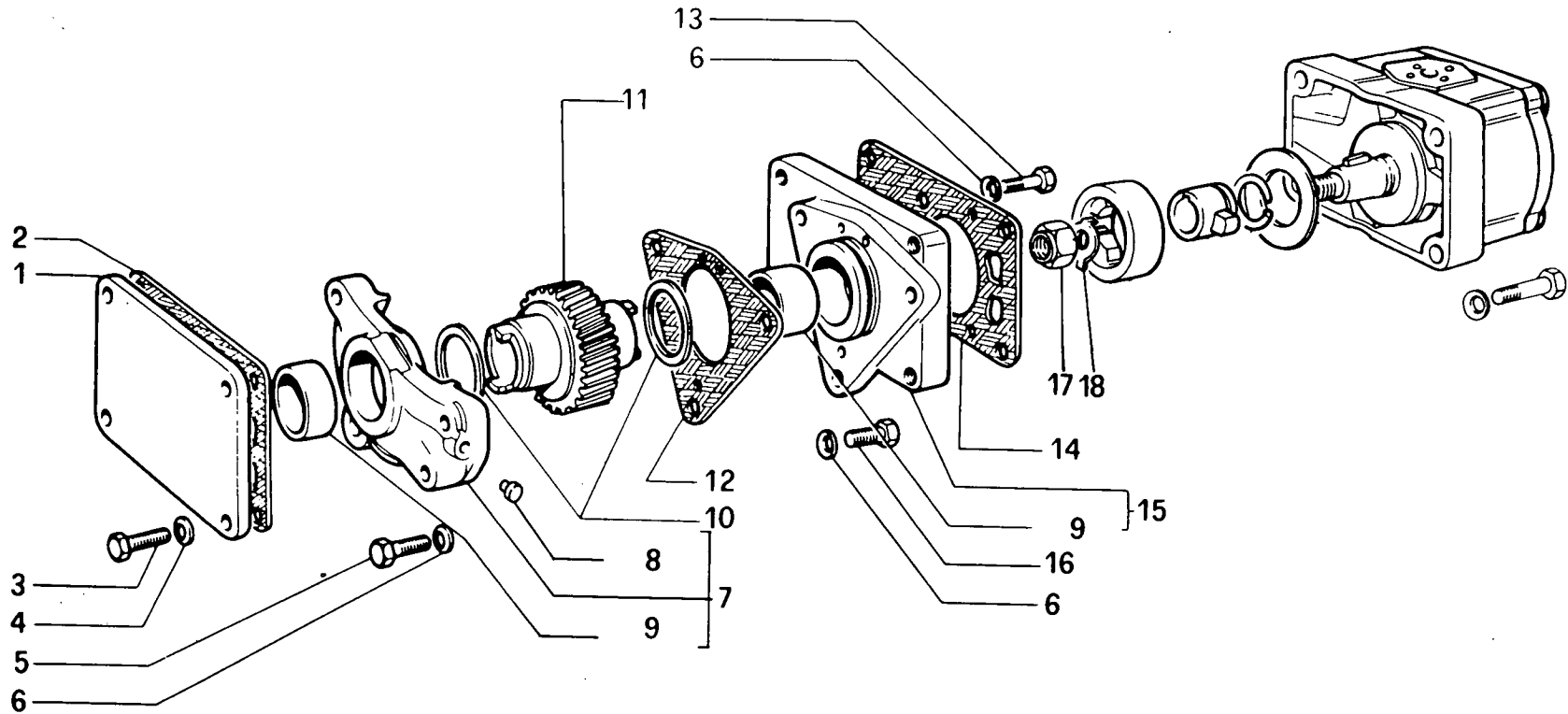

C80/50

COMANDO POMPA

90.01/02

(09-1981)

FIG	N. ORDINAZIONE	QTA	DENOMINAZIONE	DESIGNATION	BENENNUNG	DESCRIPTION	DENOMINACIONES
1	564530	1	COPERCHIO	COUVERCLE	DECKEL	COVER	TAPA
2	4607590	1	GUARNIZIONE	GARNITURE	DICHTUNG	GASKET	JUNTA
3	10902321	4	VITE	VIS	SCHRAUBE	SCREW	TORNILLO
4	11197771	4	ROSETTA DI SICUREZZA	RONDELLE FREIN	SICHERUNGSRING	LOCKWASHER	ARANDELA DE FRENO
5	16043921	3	VITE	VIS	SCHRAUBE	SCREW	TORNILLO
6	11198071	3	ROSETTA DI SICUREZZA	RONDELLE FREIN	SICHERUNGSRING	LOCKWASHER	ARANDELA DE FRENO
7	4607582	1	SUPPORTO ANTERIORE	SUPPORT	LAGER	SUPPORT	SOPORTE
8	14327101	1	TAPPO	BOUCHON	STOPFEN	PLUG	TAPON
9	4607586	1	BOCCOLA	DOUILLE	BUECHSE	BUSH	CASQUILLO
10	4667452	2	ROSETTA PIANA	RONDELLE	SCHEIBE	WASHER	ARANDELA
11	4673811	1	INGRANAGGIO	PIGNON	ZAHNRAD	GEAR	PINON
12	4619405	1	GUARNIZIONE	GARNITURE	DICHTUNG	GASKET	JUNTA
13	16044521	1	VITE	VIS	SCHRAUBE	SCREW	TORNILLO
14	4607590	1	GUARNIZIONE	GARNITURE	DICHTUNG	GASKET	JUNTA
15	4607593	1	SUPPORTO POSTERIORE	SUPPORT	LAGER	SUPPORT	SOPORTE
16	16043821	2	VITE	VIS	SCHRAUBE	SCREW	TORNILLO
17	8273919	1	DADO	ECROU	MUTTER	NUT	TUERCA
18	8273920	1	ROSETTA DI SICUREZZA	RONDELLE FREIN	SICHERUNGSRING	LOCKWASHER	ARANDELA DE FRENO

C80.50

01 02 03

POMPA

Pompe
Pumpe

Pump
Bomba

90.1/3

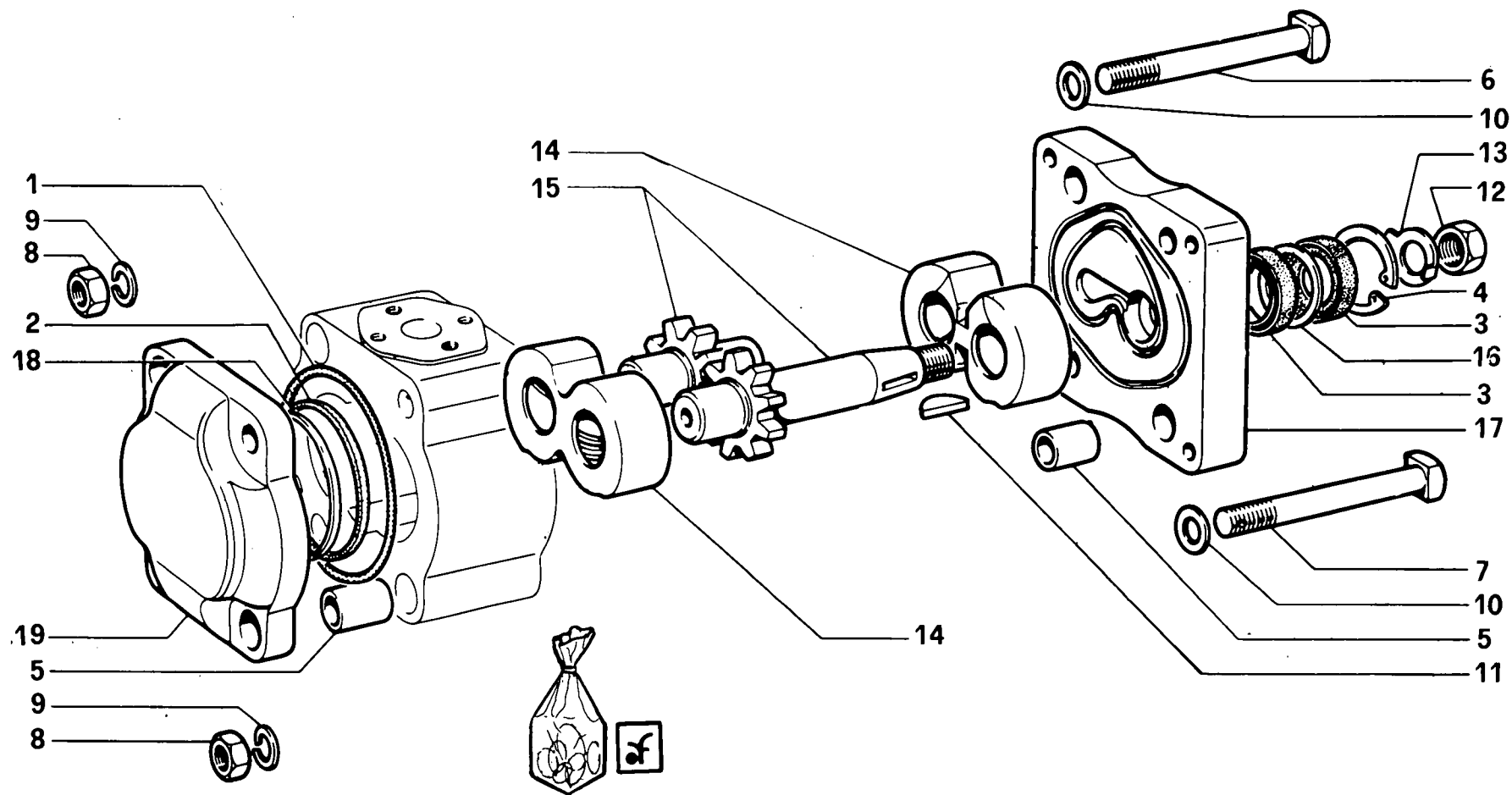

C80/50

POMPA SOLLEVATORE

90.01/03

(09-1981)

FIG	N. ORDINAZIONE	QTA	DENOMINAZIONE	DESIGNATION	BENENNUNG	DESCRIPTION	DENOMINACIONES
	568162	1	POMPA	POMPE	PUMPE	PUMP	BOMBA
	8281576	1	SERIE GUARNIZIONI	JEU DE JOINTS	DICHTUNGSSATZ	SEALING SET	LOTE JUNTAS
1	8273908	2	ANELLO OR	BAGUE TORIQUE	O-RING	O-SEAL	ANILLO O.
2	8273909	2	GUARNIZIONE	GARNITURE	DICHTUNG	GASKET	JUNTA
3	8273910	2	ANELLO DI TENUTA	JOINT D'ETANCHEITE	DICHTUNG	SEAL	JUNTA HERMETICA
4	8273911	1	ANELLO DI SICUREZZA	ARRETOIR	SICHERUNGSRING	LOCKRING	ANILLO DE FRENO
5	8273912	4	BOCCOLA	DOUILLE	BUECHSE	BUSH	CASQUILLO
6	8273913	3	VITE	VIS	SCHRAUBE	SCREW	TORNILLO
7	8273914	1	VITE	VIS	SCHRAUBE	SCREW	TORNILLO
8	8273915	4	DADO	ECROU	MUTTER	NUT	TUERCA
9	8273916	4	ROSETTA DI SICUREZZA	RONDELLE FREIN	SICHERUNGSRING	LOCKWASHER	ARANDELA DE FRENO
10	8273917	4	GUARNIZIONE DI TENUTA	JOINT	DICHTUNG	GASKET	JUNTA
11	8273918	1	LINGUETTA	LINGUET	SCHEIBENFEDER	KEY	CHAVETA
12	8273919	1	DADO	ECROU	MUTTER	NUT	TUERCA
13	8273920	1	ROSETTA DI SICUREZZA	RONDELLE FREIN	SICHERUNGSRING	LOCKWASHER	ARANDELA DE FRENO
14	8273940	2	SUPPORTO	SUPPORT	LAGER	SUPPORT	SOPORTE
15	8274231	1	COPPIA DI INGRANAGGI	COUPLE D'ENGRENAGES	ZAHNRADPAAR	GEAR SET	PAR DE ENGRANAJES
16	8280168	1	DISTANZIALE	ENTRETOISE	ABSTANDSTUECK	SPACER	SEPARADOR
17	8280170	1	FLANGIA	BRIDE	FLANSCH	FLANGE	BRIDA
18	8281201	2	ANELLO	BAGUE	RING	RING	ANILLO
19	8283478	1	COPERCHIO	COUVERCLE	DECKEL	COVER	TAPA

CE0.50

01 02 03

CORPO SOLLEVATORE

Carter de relevage
Krafthebergehäuse

Lifter Body
Cuerpo del elevador

90.1/4

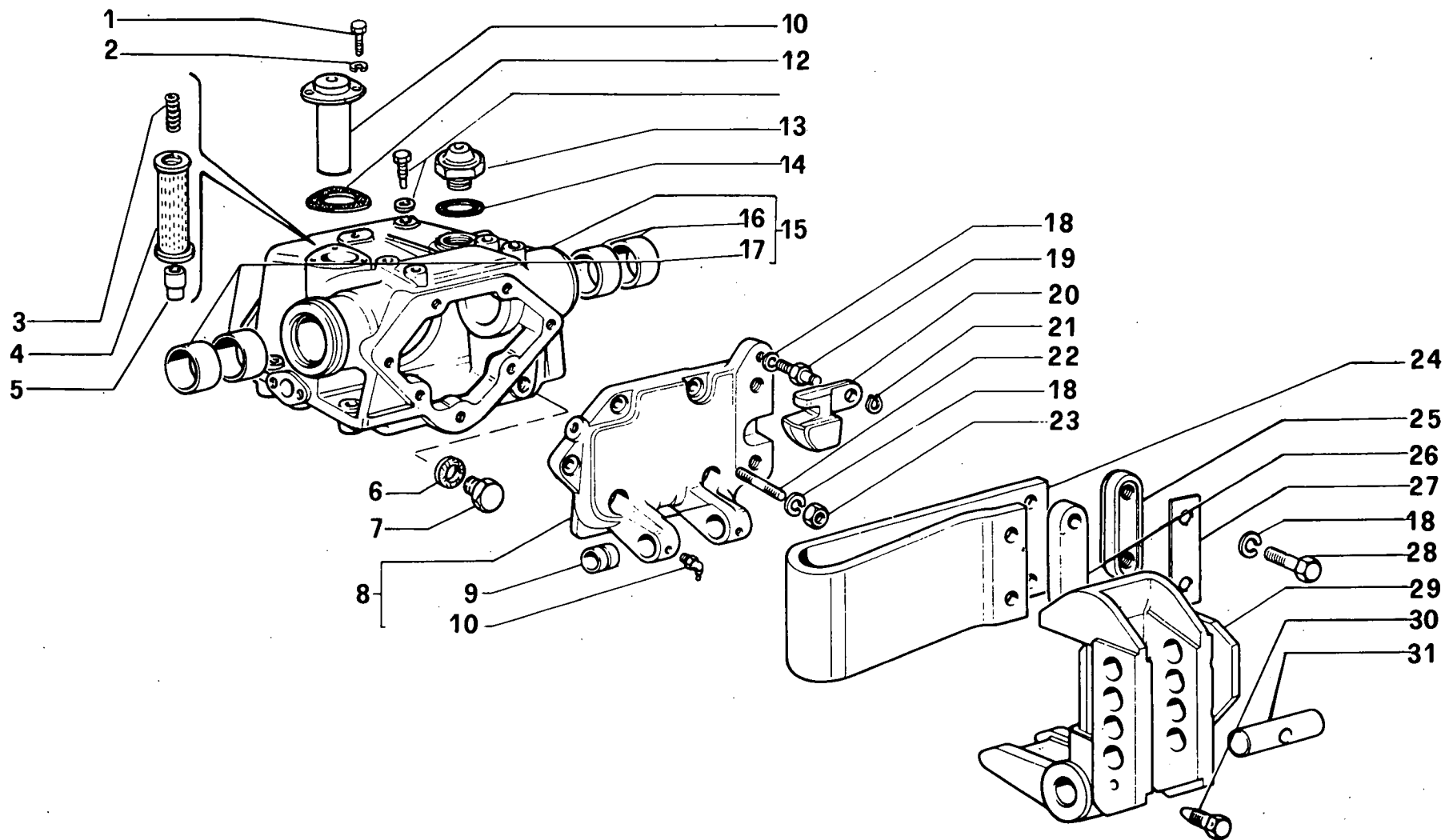

C80/50

CORPO SOLLEVATORE

90.01/04

(09-1981)

FIG	N. ORDINAZIONE	QTA	DENOMINAZIONE	DESIGNATION	BENENNUNG	DESCRIPTION	DENOMINACIONES
1	16043221	3	VITE	VIS	SCHRAUBE	SCREW	TORNILLO
2	10516671	3	ROSETTA DI SICUREZZA	RONDELLE FREIN	SICHERUNGSRING	LOCKWASHER	ARANDELA DE FRENO
3	559958	1	MOLLA	RESSORT	FEDER	SPRING	RESORTE
4	5103028	1	CARTUCCIA	CARTOUCHE	PATRONE	CARTRIDGE	CARTUCHO
5	559930	1	RACCORDO FILTRO	RACCORD	STUTZEN	CONNECTION	RACOR
6	10287385	2	GUARNIZIONE	GARNITURE	DICHTUNG	GASKET	JUNTA
7	10300511	2	TAPPO	BOUCHON	STOPFEN	PLUG	TAPON
8	571616	1	COPERCHIO	COUVERCLE	DECKEL	COVER	TAPA
9	571612	2	BOCCOLA	DOUILLE	BUECHSE	BUSH	CASQUILLO
10	13407811	2	INGRASSATORE	GRAISSER	SCHMIERNIPPEL	FITTING	ENGRASADOR
11	559994	1	COPERCHIO	COUVERCLE	DECKEL	COVER	TAPA
12	4976071	1	GUARNIZIONE DI TENUTA	JOINT	DICHTUNG	GASKET	JUNTA
13	567381	1	VITE DI SFIATO	VIS D'EVENT	ENTLUEFTUNGSSCHRAU- BE	VENT SCREW	TORNILLO DE RESPIRACION
14	10265360	1	GUARNIZIONE DI TENUTA	JOINT	DICHTUNG	GASKET	JUNTA
15	4983391	1	CORPO SOLLEVATORE	CARTER DU RELEVAGE	KRAFTHEBERGEHAUSE	LIFTER BODY	CUERPO DEL ELEVADOR
16	4955420	2	BOCCOLA DX	DOUILLE	BUECHSE	BUSH	CASQUILLO
17	4955421	2	BOCCOLA SX	DOUILLE	BUECHSE	BUSH	CASQUILLO
18	10517071	11	ROSETTA DI SICUREZZA	RONDELLE FREIN	SICHERUNGSRING	LOCKWASHER	ARANDELA DE FRENO
19	576625	1	VITE	VIS	SCHRAUBE	SCREW	TORNILLO
20	597497	1	TASSELLO	TAMPON	BEILAGE	PAD	TACO
21	11066076	1	ANELLO DI SICUREZZA	ARRETOIR	SICHERUNGSRING	LOCKRING	ANILLO DE FRENO
22	11794530	6	PRIGIONIERO	GOUJON	STIFTSCHRAUBE	STUD	ESPARRAGO
23	10790321	6	DADO	ECROU	MUTTER	NUT	TUERCA
24	596421	1	MOLLA	RESSORT	FEDER	SPRING	RESORTE
25	571609	1	PIASTRA	PLAQUE	PLATTE	PLATE	PLACA
26	571610	1	PIASTRA	PLAQUE	PLATTE	PLATE	PLACA
27	572402	SN	SPESSORE DI REGISTRO	CALE D'EPAISSEUR	DISTANZSCHEIBE	SHIM	SUPLEMENTO
28	11363021	4	VITE	VIS	SCHRAUBE	SCREW	TORNILLO
29	582092	1	SUPPORTO	SUPPORT	LAGER	SUPPORT	SOPORTE
30	4968813	1	VITE	VIS	SCHRAUBE	SCREW	TORNILLO
31	566604	1	ALBERO	ARBRE	WELLE	SHAFT	ARBOL

STANTUFFO E BRACCI SOLLEVATORE

Piston et bras de relevage
Kolben und Arme des Krafthebers

Lifter Ram and Links
Émbolo y brazos del elevador

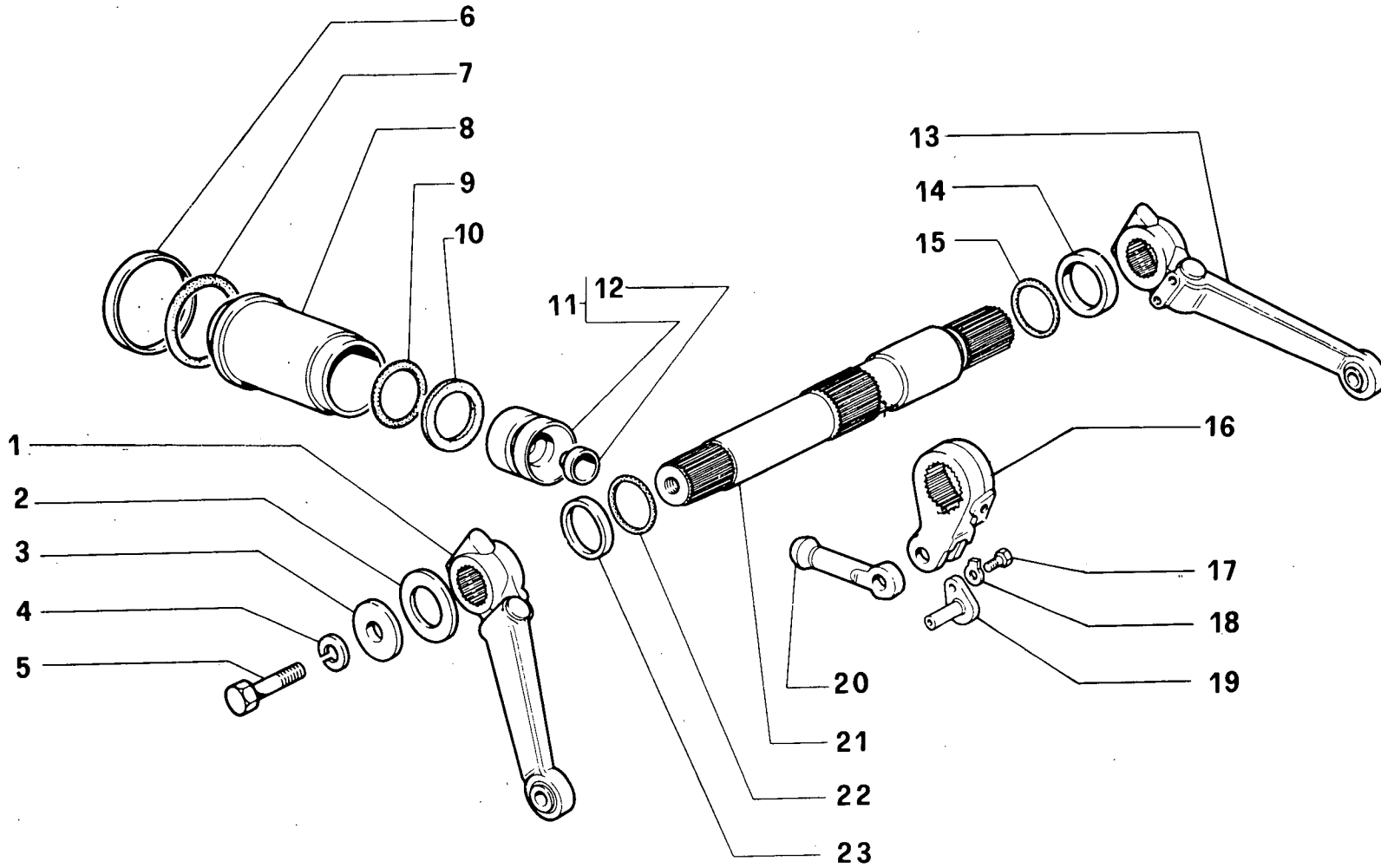

FIG	N. ORDINAZIONE	QTA	DENOMINAZIONE	DESIGNATION	BENENNUNG	DESCRIPTION	DENOMINACIONES
1	4981481	1	BRACCIO DI SOLLEVAMENTO SX (01-02)	BRAS DE LEVAGE	HUBARM	LIFT ARM	BRAZO DE ELEVACION
1	4982463	1	BRACCIO DI SOLLEVAMENTO (03)	BRAS DE LEVAGE	HUBARM	LIFT ARM	BRAZO DE ELEVACION
2	4998868	2	ROSETTA PIANA	RONDELLE	SCHEIBE	WASHER	ARANDELA
3	4981485	2	RALLA	CRAPAUDINE	DRUCKSCHEIBE	THRUST PLATE	CHUMACERA
4	10517171	2	ROSETTA DI SICUREZZA	RONDELLE FREIN	SICHERUNGSRING	LOCKWASHER	ARANDELA DE FRENO
5	11408321	2	VITE	VIS	SCHRAUBE	SCREW	TORNILLO
6	5105664	1	ANELLO DI TENUTA	JOINT D'ETANCHEITE	DICHTRING	SEAL	JUNTA HERMETICA
7	14472680	1	ANELLO OR	BAGUE TORIQUE	O-RING	O-SEAL	ANILLO O.
8	5105663	1	CILINDRO	CYLINDRE	ZYLINDER	CYLINDER	CILINDRO
9	576819	1	GUARNIZIONE	GARNITURE	DICHTUNG	GASKET	JUNTA
10	599890	1	DISCO	DISQUE	SCHEIBE	PLATE	DISCO
11	4982383	1	STANTUFFO	PISTON	KOLBEN	PISTON	EMBOLO
12	573148	1	SEDE SFERICA	SIEGE SPHERIQUE	KUGELPFANNE	BALL SOCKET	COJINETE ESFERICO
13	4981483	1	BRACCIO DI SOLLEVAMENTO DX (01-02)	BRAS DE LEVAGE	HUBARM	LIFT ARM	BRAZO DE ELEVACION
13	4982465	1	BRACCIO DI SOLLEVAMENTO (03)	BRAS DE LEVAGE	HUBARM	LIFT ARM	BRAZO DE ELEVACION
14	4981488	1	DISTANZIALE DX	ENTRETOISE	ABSTANDSTUECK	SPACER	SEPARADOR
15	14471280	1	ANELLO OR	BAGUE TORIQUE	O-RING	O-SEAL	ANILLO O.
16	4982388	1	BRACCIO INT.	BRAS	ARM	ARM	BRAZO
17	15970321	1	VITE	VIS	SCHRAUBE	SCREW	TORNILLO
18	10053610	1	PIASTRINA DI SICUREZZA	PLAQUETTE FREIN	SICHERUNGSBLECH	LOCKPLATE	PLACA DE FRENO
19	594787	1	PERNO	AXE	BOLZEN	PIN	EJE
20	4981484	1	PUNTONE	ETAI	STREBE	STRUT	TORNAPUNTA
21	4998815	1	ALBERO	ARBRE	WELLE	SHAFT	ARBOL
22	14471180	1	ANELLO OR	BAGUE TORIQUE	O-RING	O-SEAL	ANILLO O.
23	4981489	1	DISTANZIALE SX	ENTRETOISE	ABSTANDSTUECK	SPACER	SEPARADOR

C80.50

01 02 03

DISTRIBUTORE

Distributeur
Steuergerät

Distributor Valve
Válvula distribuidora

90.1/6

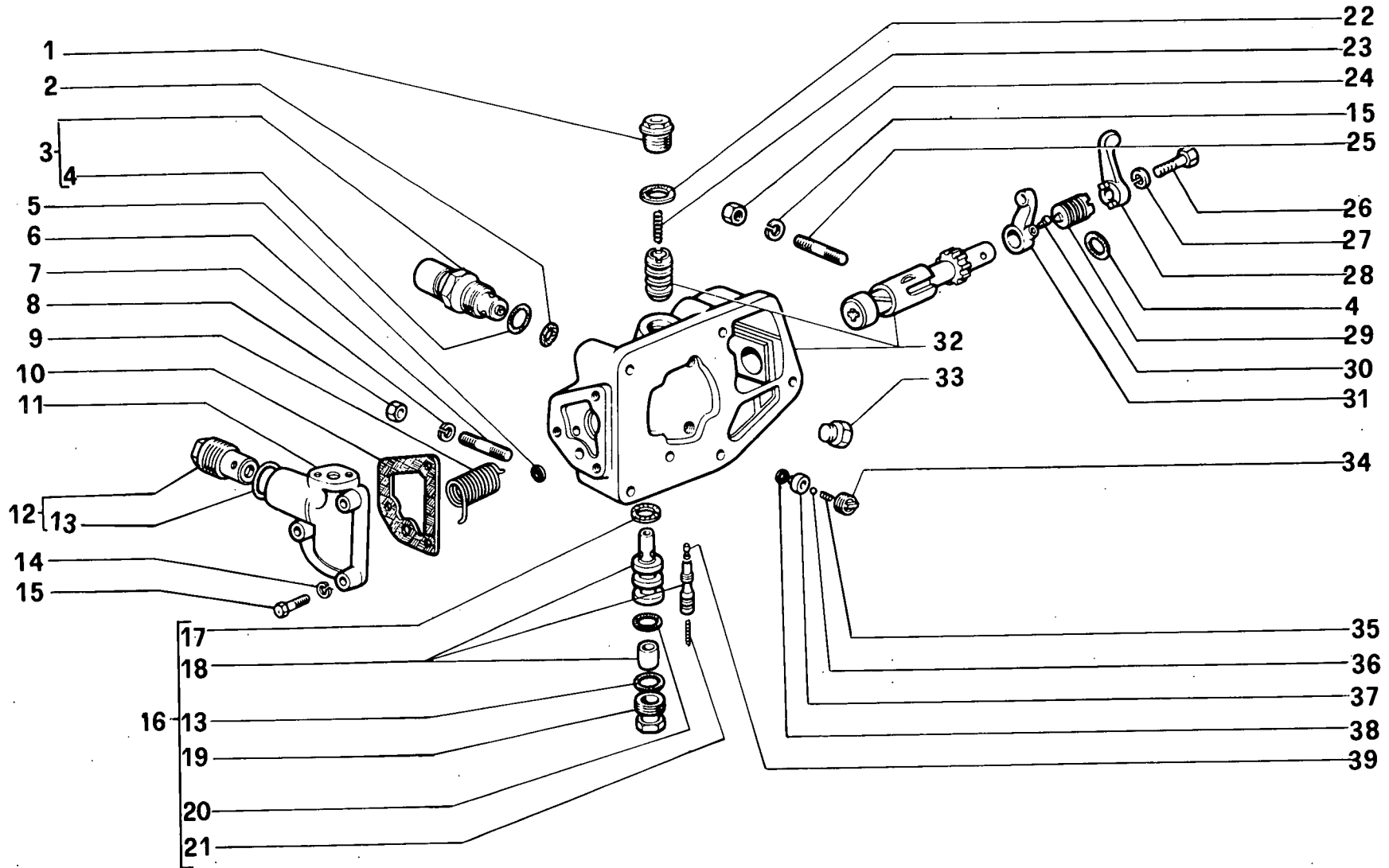

C80/50

DISTRIBUTORE

90.01/06

(09-1981)

FIG	N. ORDINAZIONE	QTA	DENOMINAZIONE	DESIGNATION	BENENNUNG	DESCRIPTION	DENOMINACIONES
1	559952	1	TAPPO VALVOLA	BOUCHON	STOPFEN	PLUG	TAPON
2	586892	1	GUARNIZIONE	GARNITURE	DICHTUNG	GASKET	JUNTA
3	4996420	1	VALVOLA LIMITAT. PRESS.	LIMITEUR DE PRESS	DRUCKBEGR. VENTIL	RELIEF VALVE	VAL. LIMIT. PRESION
4	14457480	2	ANELLO OR	BAGUE TORIQUE	O-RING	O-SEAL	ANILLO O.
5	14457080	1	ANELLO OR	BAGUE TORIQUE	O-RING	O-SEAL	ANILLO O.
6	11798120	4	PRIGIONIERO	GOUJON	STIFTSCHRAUBE	STUD	ESPARRAGO
7	10517171	4	ROSETTA DI SICUREZZA	RONDELLE FREIN	SICHERUNGSRING	LOCKWASHER	ARANDELA DE FRENO
8	10790411	4	DADO	ECROU	MUTTER	NUT	TUERCA
9	559948	1	MOLLA	RESSORT	FEDER	SPRING	RESORTE
10	598643	1	GUARNIZIONE DI TENUTA	JOINT	DICHTUNG	GASKET	JUNTA
11	564170	1	COPERCHIO	COUVERCLE	DECKEL	COVER	TAPA
12	5116211	1	VALVOLA PRESSIONE	SOUPAPE	VENTIL	VALVE	VALVULA
13	14463080	1	ANELLO OR	BAGUE TORIQUE	O-RING	O-SEAL	ANILLO O.
14	10516871	3	ROSETTA DI SICUREZZA	RONDELLE FREIN	SICHERUNGSRING	LOCKWASHER	ARANDELA DE FRENO
15	15888721	3	VITE	VIS	SCHRAUBE	SCREW	TORNILLO
16	5101910	1	VALVOLA DI SCARICO	SOUPAPE D'ECHAPPEMENT	AUSLASSVENTIL	EXHAUST VALVE	VALVULA DE ESCAPE
17	571601	1	GUARNIZIONE DI TENUTA	JOINT	DICHTUNG	GASKET	JUNTA
18	5100807	1	OTTURATORE	OBTURATEUR	VERSCHLUSSSTUECK	PLUG/LOCK	PIEZA DE CIERRE
19	5100804	1	TAPPO	BOUCHON	STOPFEN	PLUG	TAPON
20	14457180	1	ANELLO OR	BAGUE TORIQUE	O-RING	O-SEAL	ANILLO O.
21	5100806	1	MOLLA	RESSORT	FEDER	SPRING	RESORTE
22	10296260	1	GUARNIZIONE DI TENUTA	JOINT	DICHTUNG	GASKET	JUNTA
23	559958	1	MOLLA	RESSORT	FEDER	SPRING	RESORTE
24	10790111	1	DADO	ECROU	MUTTER	NUT	TUERCA
25	13450320	1	PRIGIONIERO	GOUJON	STIFTSCHRAUBE	STUD	ESPARRAGO
26	16043621	1	VITE	VIS	SCHRAUBE	SCREW	TORNILLO
27	10516671	1	ROSETTA DI SICUREZZA	RONDELLE FREIN	SICHERUNGSRING	LOCKWASHER	ARANDELA DE FRENO
28	590241	1	LEVA	LEVIER	HEBEL	LEVER	PALANCA
29	590240	1	TAPPO	BOUCHON	STOPFEN	PLUG	TAPON
30	4968815	1	VITE	VIS	SCHRAUBE	SCREW	TORNILLO
31	559950	1	LEVA	LEVIER	HEBEL	LEVER	PALANCA
32	4987809	1	CORPO DISTRIBUTORE	CORPS	GEHAUSE	BODY	CUERPO
33	14324901	1	TAPPO	BOUCHON	STOPFEN	PLUG	TAPON
34	4999664	1	TAPPO	BOUCHON	STOPFEN	PLUG	TAPON

DISTRIBUTORE

Distributeur
Steuergerät

Distributor Valve
Válvula distribuidora

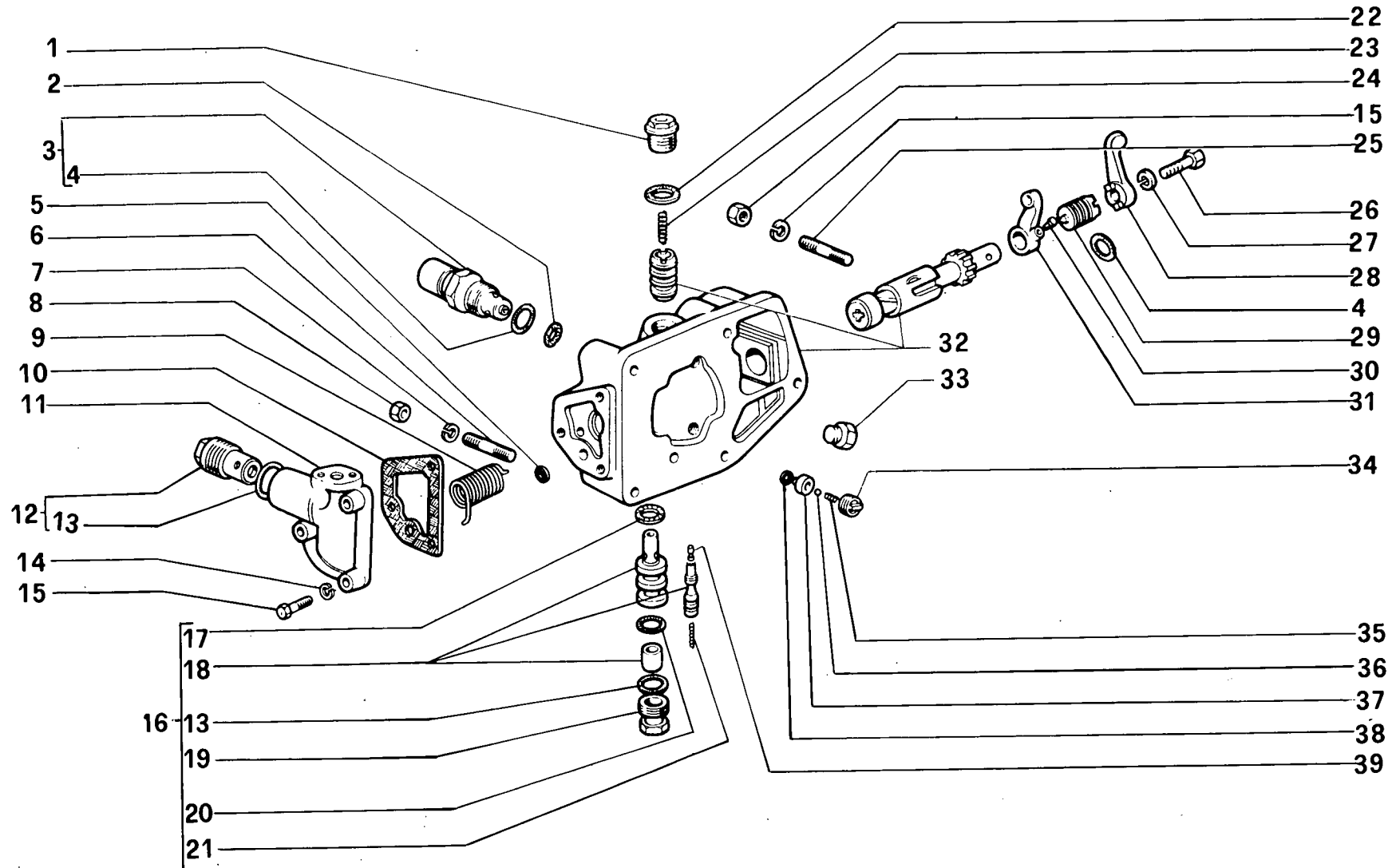

C80/50

DISTRIBUTORE

90.01/06

(09-1981)

FIG	N. ORDINAZIONE	QTA	DENOMINAZIONE	DESIGNATION	BENENNUNG	DESCRIPTION	DENOMINACIONES
35	596854	1	MOLLA	RESSORT	FEDER	SPRING	RESORTE
36	20063490	1	SFERA	BILLE	KUGEL	BALL	BOLA
37	592118	1	SEDE VALVOLA	SIEGE DE SOUPAPE	VENTILSITZ	VALVE SEAT	ASIEN TO DE VALVOLA
38	14459280	1	ANELLO OR	BAGUE TORIQUE	O-RING	O-SEAL	ANILLO O.
39	571600	1	PUNTALE	TIGE	DRUCKSTANGE	ROD	VASTAGO

C80.50

01 02 03

COMANDI INTERNI SOLLEVATORE

Commandes intérieures de relevage
Innere Betätigung des Krafthebers

Lifter Inner Controls
Mandos interiores del elevador

90.1/7

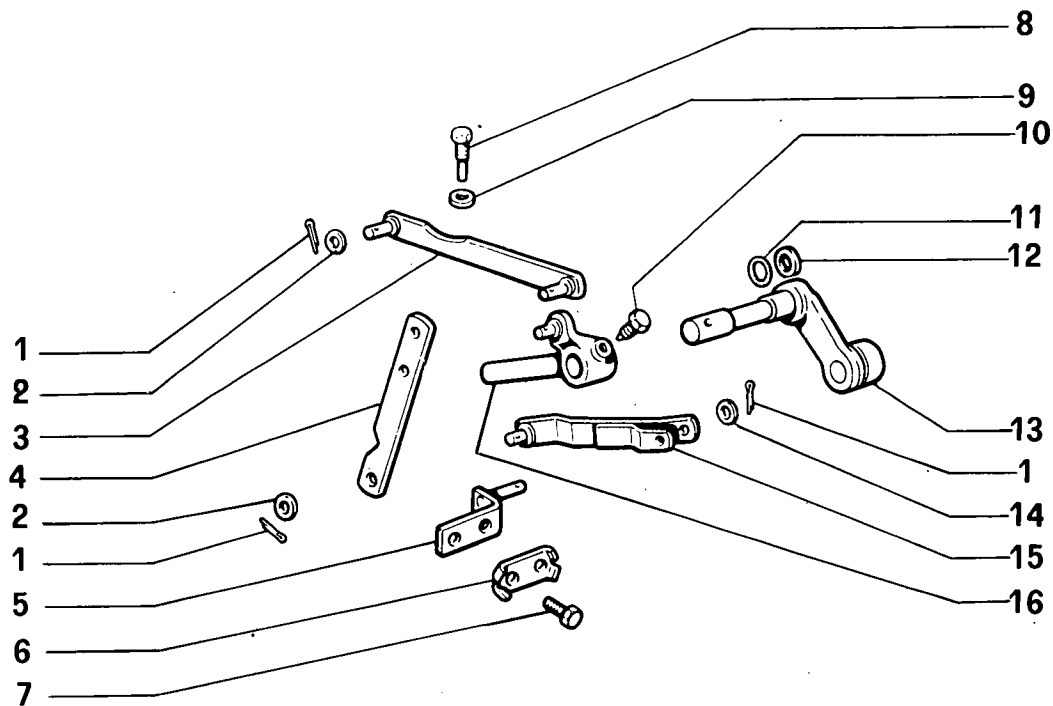

C80/50

COMANDI INTERNI SOLLEVATORE

90.01/07

(09-1981)

FIG	N. ORDINAZIONE	QTA	DENOMINAZIONE	DESIGNATION	BENENNUNG	DESCRIPTION	DENOMINACIONES
1	10734201	5	COPIGLIA	GOUPILLE	SPLINT	SPLIT PIN	PASADOR ABIERTO
2	10519601	4	ROSETTA DI SICUREZZA	RONDELLE FREIN	SICHERUNGSRING	LOCKWASHER	ARANDELA DE FRENO
3	5111551	1	TIRANTE	TIRANT	STANGE	ROD	VARILLA
4	4983949	1	BILANCIERE	CULBUTEUR	KIPPHEBEL	ROCKER	BALANCIN
5	5110185	1	SUPPORTO	SUPPORT	LAGER	SUPPORT	SOPORTE
6	569857	2	PIASTRINA DI SICUREZZA	PLAQUETTE FREIN	SICHERUNGSBLECH	LOCKPLATE	PLACA DE FRENO
7	15970521	2	VITE	VIS	SCHRAUBE	SCREW	TORNILLO
8	576493	1	VITE DI REGISTRO L 58mm	VIS DE REGLAGE	EINSTELLSCHRAUBE	ADJUSTING SCREW	TORNILLO GRADUACION
8	4982242	-	VITE DI REGISTRO L 63mm	VIS DE REGLAGE	EINSTELLSCHRAUBE	ADJUSTING SCREW	TORNILLO GRADUACION
9	559955	SN	PIASTRINA	PLAQUETTE	PLAETTCHEN	PLATE	PLACA
10	4968815	1	VITE	VIS	SCHRAUBE	SCREW	TORNILLO
11	559983	1	GUARNIZIONE	GARNITURE	DICHTUNG	GASKET	JUNTA
12	596377	1	ANELLO	BAGUE	RING	RING	ANILLO
13	566576	1	LEVA	LEVIER	HEBEL	LEVER	PALANCA
14	12638601	1	ROSETTA PIANA	RONDELLE	SCHEIBE	WASHER	ARANDELA
15	5111552	1	TIRANTE	TIRANT	STANGE	ROD	VARILLA
16	573180	1	LEVA	LEVIER	HEBEL	LEVER	PALANCA

COMANDI ESTERNI SOLLEVATORE

Commandes extérieures de relevage
Äussere Betätigung des Krafthebers

Lifter Outer Controls
Mandos exteriores del elevador

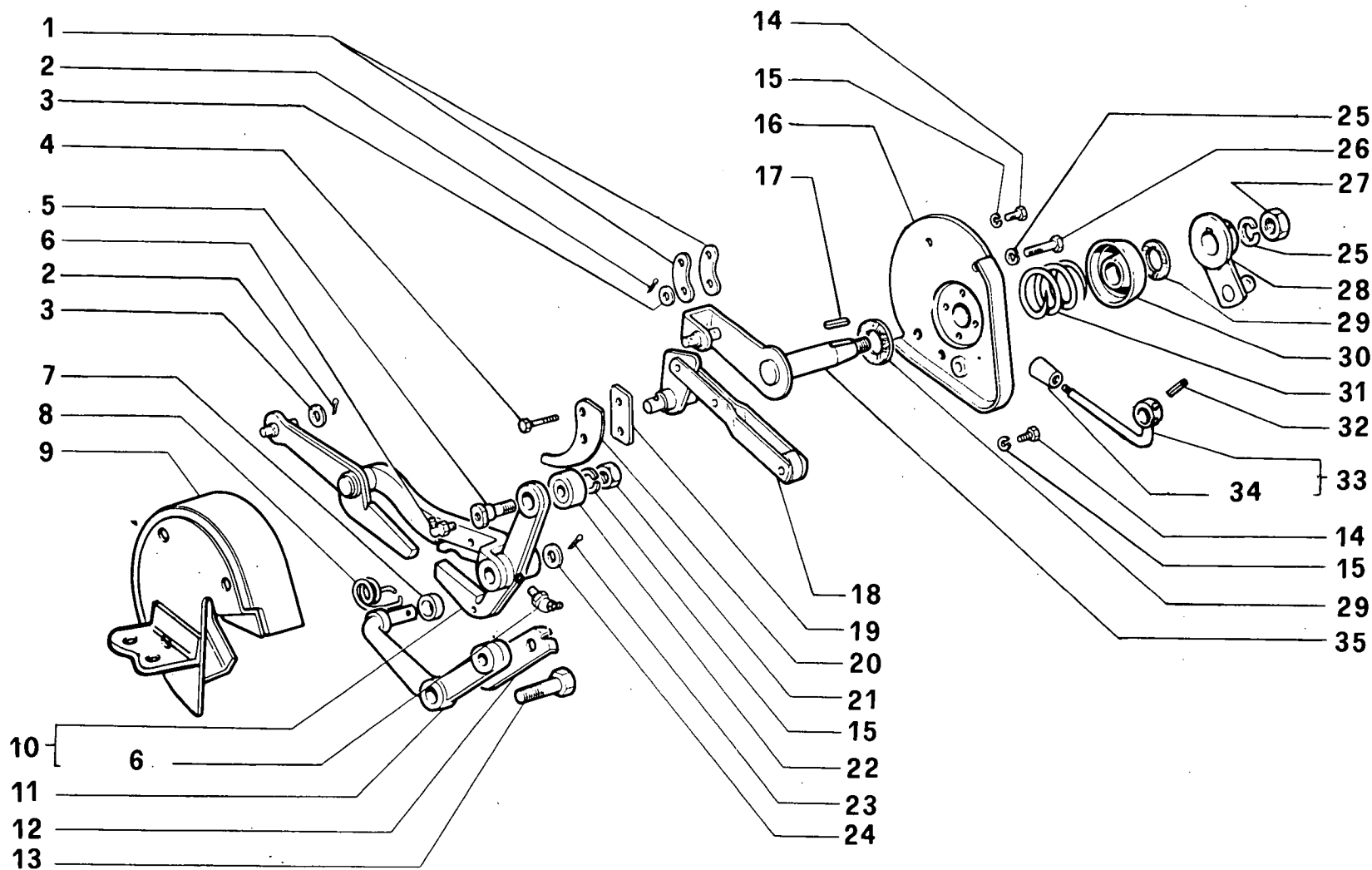
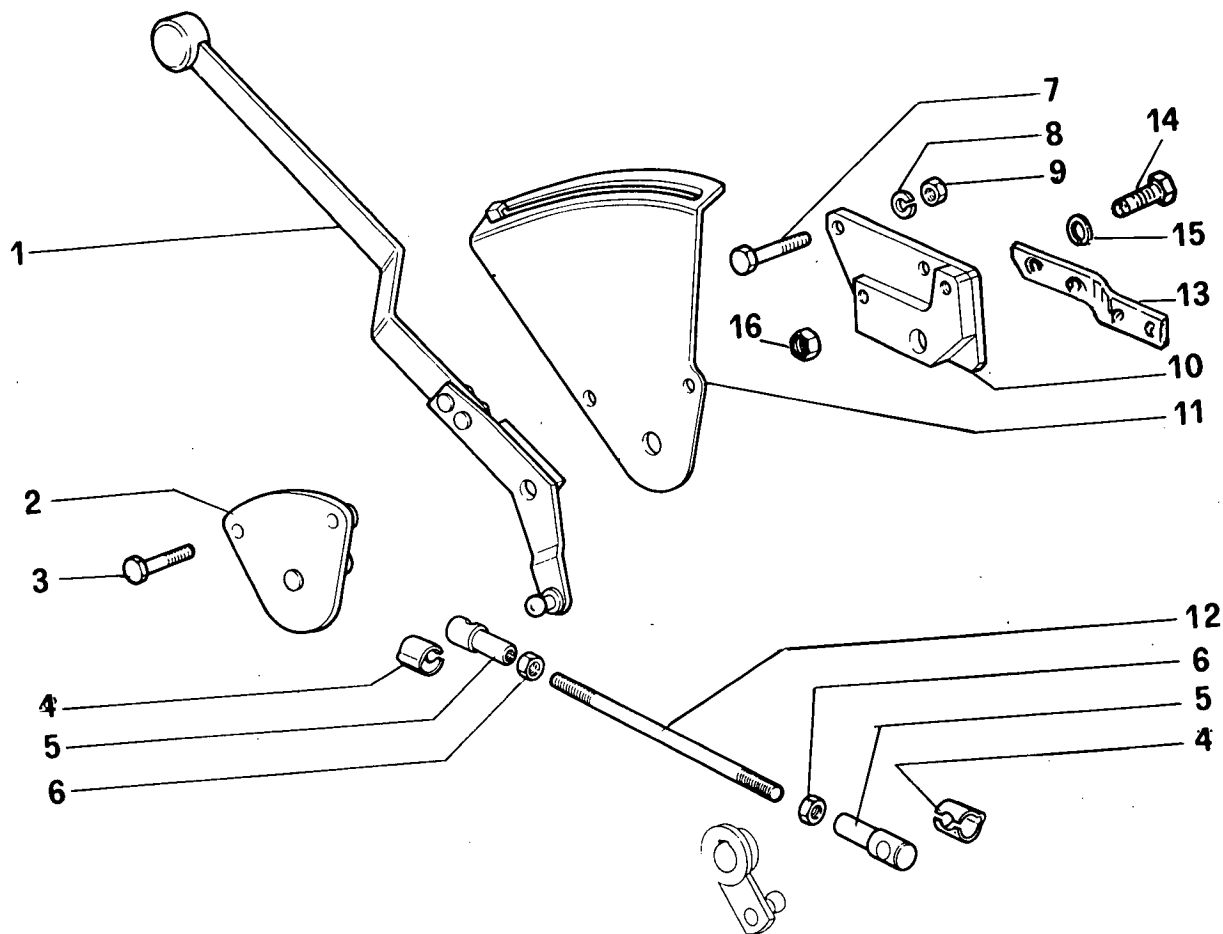

FIG	N. ORDINAZIONE	QTA	DENOMINAZIONE	DESIGNATION	BENENNUNG	DESCRIPTION	DENOMINACIONES
1	589774	2	BIELLETTA	BIELLE CONNEXION	ANLENKPLEUELSTANGE	CONNECTING ROD	BIELA ATAQUE
2	10734201	4	COPIGLIA	GOUPILLE	SPLINT	SPLIT PIN	PASADOR ABIERTO
3	12642701	4	ROSETTA DI SICUREZZA	RONDELLE FREIN	SICHERUNGSRING	LOCKWASHER	ARANDELA DE FRENO
4	11306921	2	VITE	VIS	SCHRAUBE	SCREW	TORNILLO
5	596671	1	PERNO	AXE	BOLZEN	PIN	EJE
6	13406711	1	INGRASSATORE	GRAISSER	SCHMIERNIPPEL	FITTING	ENGRASADOR
7	14543170	2	BOCCOLA	DOUILLE	BUECHSE	BUSH	CASQUILLO
8	567861	1	MOLLA	RESSORT	FEDER	SPRING	RESORTE
9	4983094	1	RIPARO	PROTECTION	ABDECKUNG	PROTECTION	DEFENSA
10	566594	1	LEVA	LEVIER	HEBEL	LEVER	PALANCA
11	4982404	1	LEVA COMANDO	LEVIER	HEBEL	LEVER	PALANCA
12	553209	1	PIASTRINA DI SICUREZZA	PLAQUETTE FREIN	SICHERUNGSBLECH	LOCKPLATE	PLACA DE FRENO
13	15970921	2	VITE	VIS	SCHRAUBE	SCREW	TORNILLO
14	16043221	2	VITE	VIS	SCHRAUBE	SCREW	TORNILLO
15	10516671	2	ROSETTA DI SICUREZZA	RONDELLE FREIN	SICHERUNGSRING	LOCKWASHER	ARANDELA DE FRENO
16	4983101	1	COPERCHIO	COUVERCLE	DECKEL	COVER	TAPA
17	10617010	1	LINGUETTA	LINGUET	SCHEIBENFEDER	KEY	CHAVETA
18	4987044	1	LEVA INTERNA	LEVIER	HEBEL	LEVER	PALANCA
19	4998867	1	DISTANZIALE	ENTRETOISE	ABSTANDSTUECK	SPACER	SEPARADOR
20	4982381	1	SETTORE	TIRANT	SPREIZTANGE	STRUT	BIELA
21	16102311	2	DADO	ECROU	MUTTER	NUT	TUERCA
22	596673	1	RULLO	GALET	ROLLE	ROLLER	RODILLO
23	10733601	1	COPIGLIA	GOUPILLE	SPLINT	SPLIT PIN	PASADOR ABIERTO
24	10520001	1	ROSETTA PIANA	RONDELLE	SCHEIBE	WASHER	ARANDELA
25	10516871	2	ROSETTA DI SICUREZZA	RONDELLE FREIN	SICHERUNGSRING	LOCKWASHER	ARANDELA DE FRENO
26	15971321	1	VITE	VIS	SCHRAUBE	SCREW	TORNILLO
27	12164711	1	DADO	ECROU	MUTTER	NUT	TUERCA
28	5110167	1	LEVA	LEVIER	HEBEL	LEVER	PALANCA
29	566864	1	DISCO DI FRIZIONE	DISQUE DE FRICTION	REIBSCHEIBE	FRICTION DISC	PLATO FRICCION
30	566559	1	SCODELLINO	CUVETTE	TELLERSCHEIBE	CUP	PLATILLO
31	559970	1	MOLLA	RESSORT	FEDER	SPRING	RESORTE
32	14166170	1	SPINA	GOUPILLE	STIFT	PIN	PASADOR
33	5110213	1	LEVA	LEVIER	HEBEL	LEVER	PALANCA
34	561880	1	IMPUGNATURA	POIGNEE	GRIF	KNOB	BOTON
35	587762	1	PERNO	AXE	BOLZEN	PIN	EJE

COMANDI ESTERNI SOLLEVATORE

Commandes extérieures de relevage
Äussere Betätigung des Krafthebers

Lifter Outer Controls
Mandos exteriores del elevador



C80/50

COMANDI ESTERNI

90.01/09 (09-1981)

FIG	N. ORDINAZIONE	QTA	DENOMINAZIONE	DESIGNATION	BENENNUNG	DESCRIPTION	DENOMINACIONES
1	5110170	1	LEVA COMPL.	LEVIER	HEBEL	LEVER	PALANCA
2	5110190	1	RIPARO LEVA	PROTECTION	ABDECKUNG	PROTECTION	DEFENSA
3	16043221	2	VITE	VIS	SCHRAUBE	SCREW	TORNILLO
4	10125576	2	MOLLA	RESSORT	FEDER	SPRING	RESORTE
5	10124511	2	TESTA GIUNTO	JOINT A ROTULE	STANGENKOPF	HEAD	ARTICULACION
6	16102311	2	DADO	ECROU	MUTTER	NUT	TUERCA
7	11422321	2	VITE	VIS	SCHRAUBE	SCREW	TORNILLO
8	10517171	2	ROSETTA DI SICUREZZA	RONDELLE FREIN	SICHERUNGSRING	LOCKWASHER	ARANDELA DE FRENO
9	12164011	2	DADO	ECROU	MUTTER	NUT	TUERCA
10	5110164	1	SUPPORO SETTORE	SUPPORT	LAGER	SUPPORT	SOPORTE
11	5110179	1	SETTORE	TIRANT	SPREIZTANGE	STRUT	BIELA
12	5110186	1	TIRANTE (01-02)	TIRANT	STANGE	ROD	VARILLA
12	5121196	1	TIRANTE (03)	TIRANT	STANGE	ROD	VARILLA
13	5118070	1	STAFFA (03)	ETRIER	HALTER	BRACKET	SOPORTE
14	15970721	2	VITE (03)	VIS	SCHRAUBE	SCREW	TORNILLO
15	10581871	2	ROSETTA DI SICUREZZA (03)	RONDELLE FREIN	SICHERUNGSRING	LOCKWASHER	ARANDELA DE FRENO
16	12164711	2	DADO (03)	ECROU	MUTTER	NUT	TUERCA

C80.50

01 02 03

SOLLEVATORE A MARTINETTI - 821 -

Relevage a cilindres ydrauliques
Hydraulikzylinderkraftheber

Ydraulic cylinder lifter
Elevador cilindros idraulicos

90.2/1

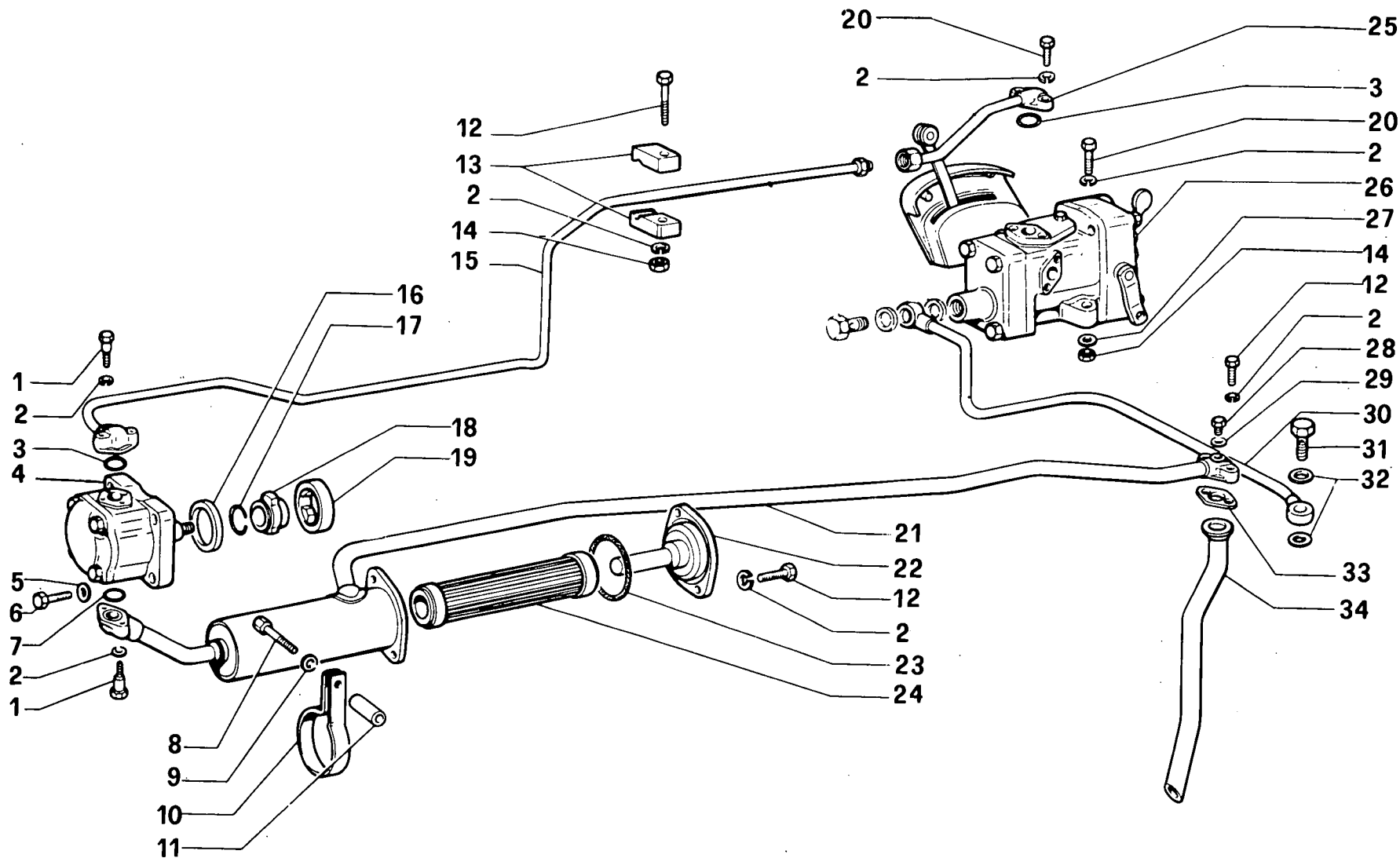

FIG	N. ORDINAZIONE	QTA	DENOMINAZIONE	DESIGNATION	BENENNUNG	DESCRIPTION	DENOMINACIONES
1	568292	4	VITE	VIS	SCHRAUBE	SCREW	TORNILLO
2	10516671	5	ROSETTA DI SICUREZZA	RONDELLE FREIN	SICHERUNGSRING	LOCKWASHER	ARANDELA DE FRENO
3	14457180	2	ANELLO OR	BAGUE TORIQUE	O-RING	O-SEAL	ANILLO O.
4	568182	1	POMPA	POMPE	PUMPE	PUMP	BOMBA
5	10519401	4	ROSETTA DI SICUREZZA	RONDELLE FREIN	SICHERUNGSRING	LOCKWASHER	ARANDELA DE FRENO
6	10903021	4	VITE	VIS	SCHRAUBE	SCREW	TORNILLO
7	14457280	1	ANELLO OR	BAGUE TORIQUE	O-RING	O-SEAL	ANILLO O.
8	15888821	1	VITE	VIS	SCHRAUBE	SCREW	TORNILLO
9	10516871	1	ROSETTA DI SICUREZZA	RONDELLE FREIN	SICHERUNGSRING	LOCKWASHER	ARANDELA DE FRENO
10	4953882	1	STAFFA	ETRIER	HALTER	BRACKET	SOPORTE
11	4953883	1	DISTANZIALE	ENTRETOISE	ABSTANDSTUECK	SPACER	SEPARADOR
12	16044321	3	VITE	VIS	SCHRAUBE	SCREW	TORNILLO
13	4953881	2	BLOCCHETTO DI FISSAGGIO	TAQUET DI FIXATION	SPANNSTUECK	PAD	MULETILLA DE FIJACION
14	16100821	1	DADO	ECROU	MUTTER	NUT	TUERCA
15	4975657	1	TUBO DI MANDATA ANT.	CONDUITE DE REFOUL	DRUCKLEITUNG	DELIVERY LINE	TUBERIA PRESION
16	5118568	1	ANELLO DI CENTRAGGIO	BAGUE	RING	RING	ANILLO
17	13401476	1	ANELLO DI SICUREZZA	ARRETOIR	SICHERUNGSRING	LOCKRING	ANILLO DE FRENO
18	5118570	1	GIUNTO	ACCOUPLMENT	KUPPLUNG	COUPLING	ARRASTRE
19	5118569	1	MOZZO	MOYEU	NABE	HUB	FUJE
20	16044021	2	VITE	VIS	SCHRAUBE	SCREW	TORNILLO
21	4956592	1	TUBO ASPIRAZIONE ANT.	TUYAU ASPIRATION	SAUGROHR	SUCTION PIPE	TUBO ASPIRACION
22	595926	1	COPERCHIO	COUVERCLE	DECKEL	COVER	TAPA
23	14464580	1	ANELLO OR	BAGUE TORIQUE	O-RING	O-SEAL	ANILLO O.
24	5103031	1	CARTUCCIA	CARTOUCHE	PATRONE	CARTRIDGE	CARTUCHO
25	4975658	1	TUBO DI MANDATA POST.	CONDUITE DE REFOUL	DRUCKLEITUNG	DELIVERY LINE	TUBERIA PRESION
25	4956604	1	TUBO DI MANDATA POST. (812)	CONDUITE DE REFOUL	DRUCKLEITUNG	DELIVERY LINE	TUBERIA PRESION
26	4956626	1	DISTRIBUTORE COMPLETO	DISTRIBUTEUR	STEUERGERAET	DISTRIBUTOR VALVE	VALVULA
27	10519601	3	ROSETTA DI SICUREZZA	RONDELLE FREIN	SICHERUNGSRING	LOCKWASHER	ARANDELA DE FRENO
28	581658	1	TAPPO	BOUCHON	STOPFEN	PLUG	TAPON
29	10260060	1	GUARNIZIONE	GARNITURE	DICHTUNG	GASKET	JUNTA
30	4953880	1	TUBO	TUBE/TUYAU	ROHR	PIPE/TUBE	TUBO
31	10184411	1	BOCCHETTONE	VIS-RACCORD	HOLHLSCHRAUBE	UNION	BOQUILLA
32	10257060	2	GUARNIZIONE	GARNITURE	DICHTUNG	GASKET	JUNTA
33	4953797	1	GUARNIZIONE	GARNITURE	DICHTUNG	GASKET	JUNTA

CEB 50

01 02 03

SOLLEVATORE A MARTINETTI - 821 -

Relevage a cilindres ydrauliques
Hydraulikzylinderkraftheber

Ydraulic cylinder lifter
Elevador cilindros idraulicos

90.2/1

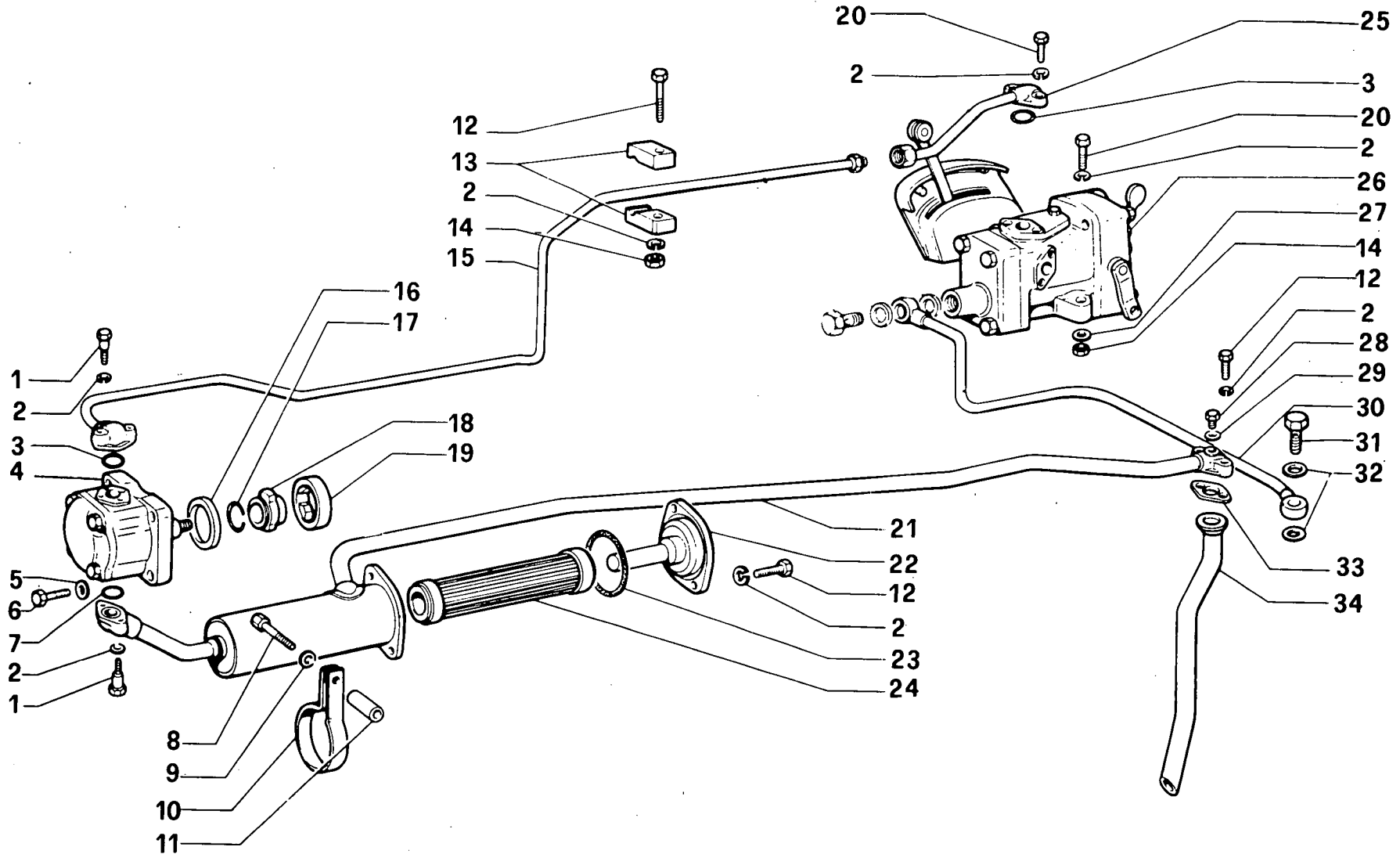

C80/50

SOLLEVATORE A MARTINETTI - 821 -

90.02/01

(09-1981)

FIG	N. ORDINAZIONE	QTA	DENOMINAZIONE	DÉSIGNATION	BENENNUNG	DESCRIPTION	DENOMINACIONES
34	4953805	1	TUBO	TUBE/TUYAU	ROHR	PIPE/TUBE	TUBO

Pompe
Pumpe

Pump
Bomba

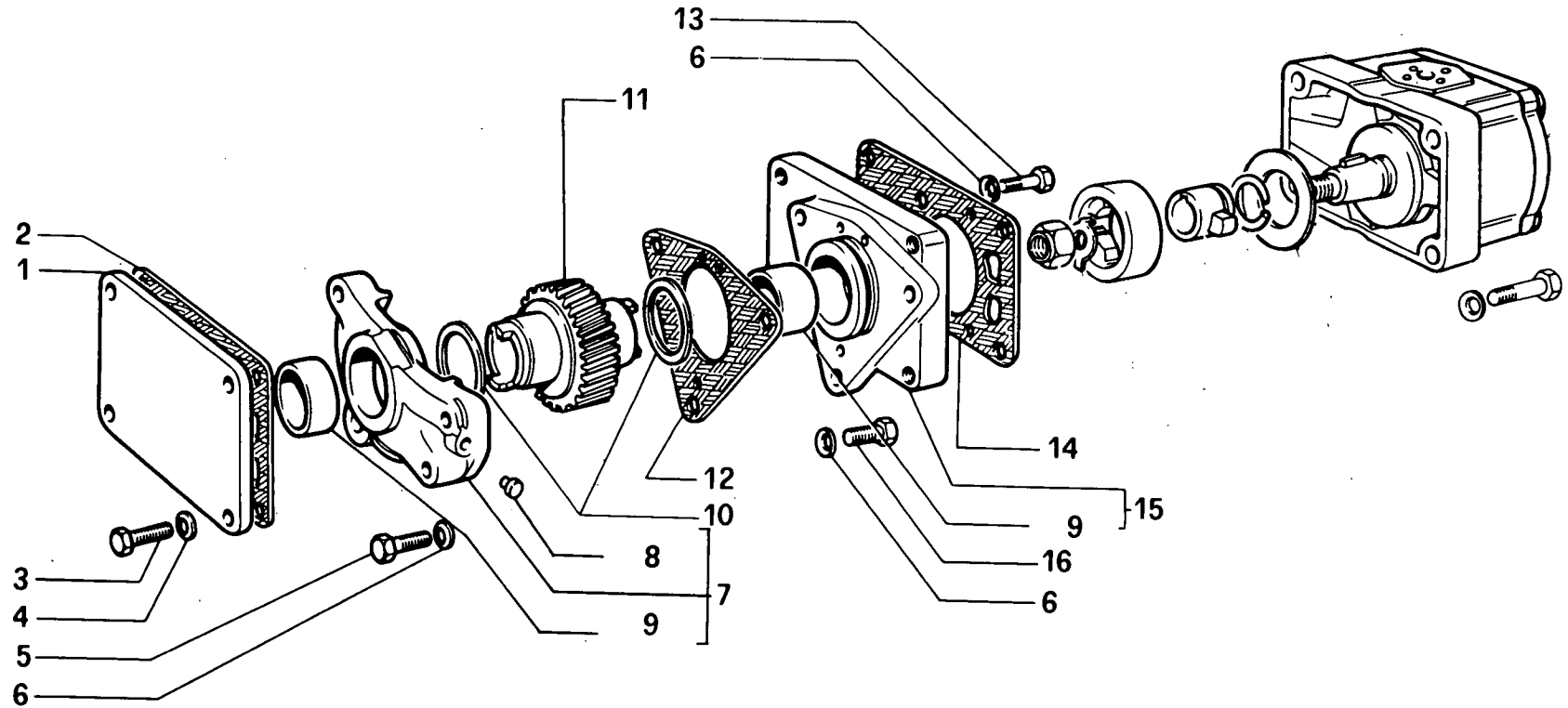

C80/50

COMANDO POMPA - 821 -

90.02/02

(09-1981)

FIG	N. ORDINAZIONE	QTA	DENOMINAZIONE	DESIGNATION	BENENNUNG	DESCRIPTION	DENOMINACIONES
1	564530	1	COPERCHIO	COUVERCLE	DECKEL	COVER	TAPA
2	4607590	1	GUARNIZIONE	GARNITURE	DICHTUNG	GASKET	JUNTA
3	10902321	4	VITE	VIS	SCHRAUBE	SCREW	TORNILLO
4	11197771	4	ROSETTA DI SICUREZZA	RONDELLE FREIN	SICHERUNGSRING	LOCKWASHER	ARANDELA DE FRENO
5	16043921	3	VITE	VIS	SCHRAUBE	SCREW	TORNILLO
6	11198071	3	ROSETTA DI SICUREZZA	RONDELLE FREIN	SICHERUNGSRING	LOCKWASHER	ARANDELA DE FRENO
7	4607582	1	SUPPORTO ANTERIORE	SUPPORT	LAGER	SUPPORT	SOPORTE
8	14327101	1	TAPPO	BOUCHON	STOPFEN	PLUG	TAPON
9	4607586	1	BOCCOLA	DOUILLE	BUECHSE	BUSH	CASQUILLO
10	4667452	2	ROSETTA PIANA	RONDELLE	SCHEIBE	WASHER	ARANDELA
11	4621357	1	INGRANAGGIO	PIGNON	ZAHNRAD	GEAR	PINON
12	4619405	1	GUARNIZIONE	GARNITURE	DICHTUNG	GASKET	JUNTA
13	16044521	1	VITE	VIS	SCHRAUBE	SCREW	TORNILLO
14	4607590	1	GUARNIZIONE	GARNITURE	DICHTUNG	GASKET	JUNTA
15	4607593	1	SUPPORTO POSTERIORE	SUPPORT	LAGER	SUPPORT	SOPORTE
16	16043821	2	VITE	VIS	SCHRAUBE	SCREW	TORNILLO

Pompe
Pumpe

Pump
Bomba

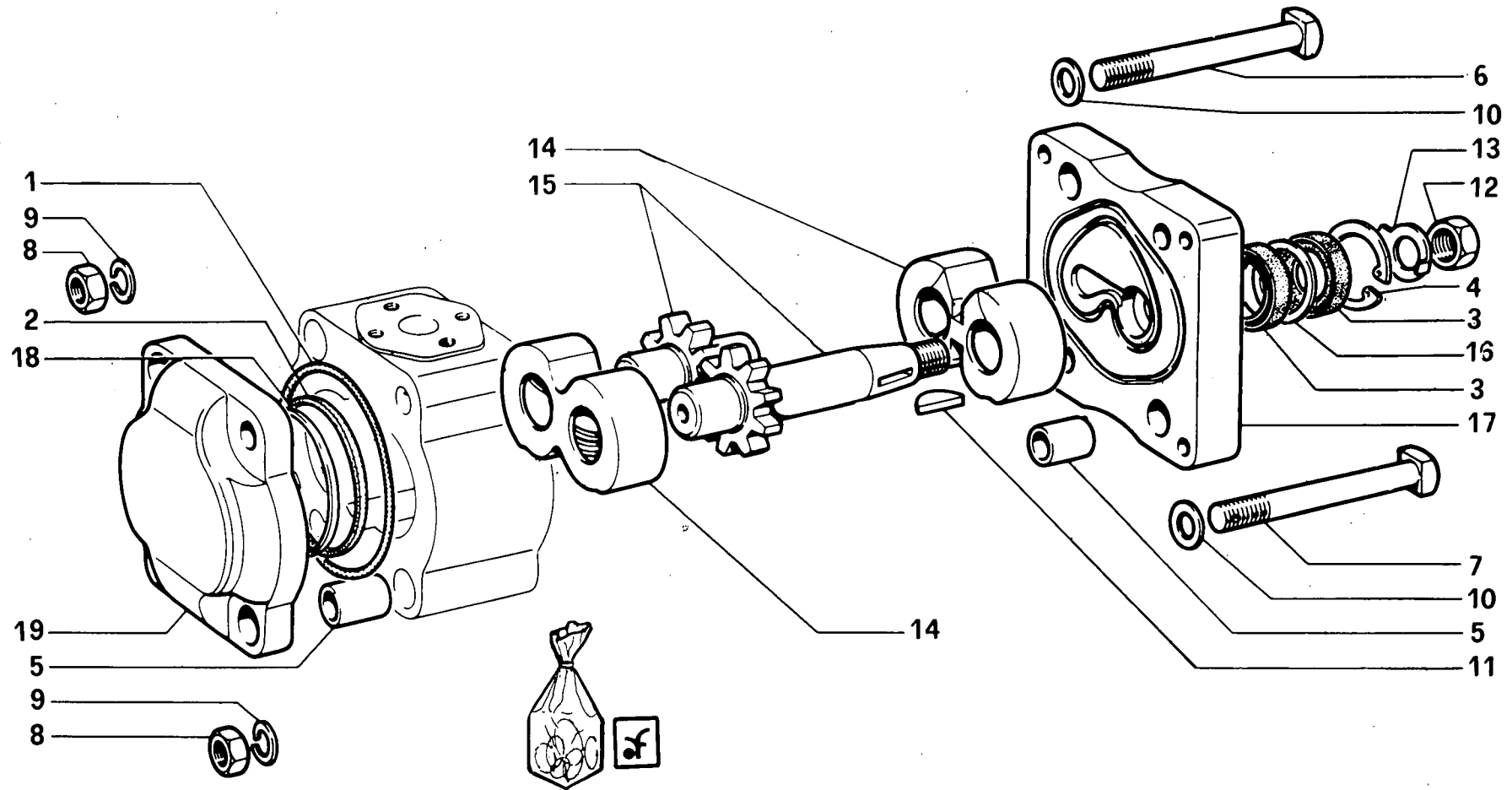
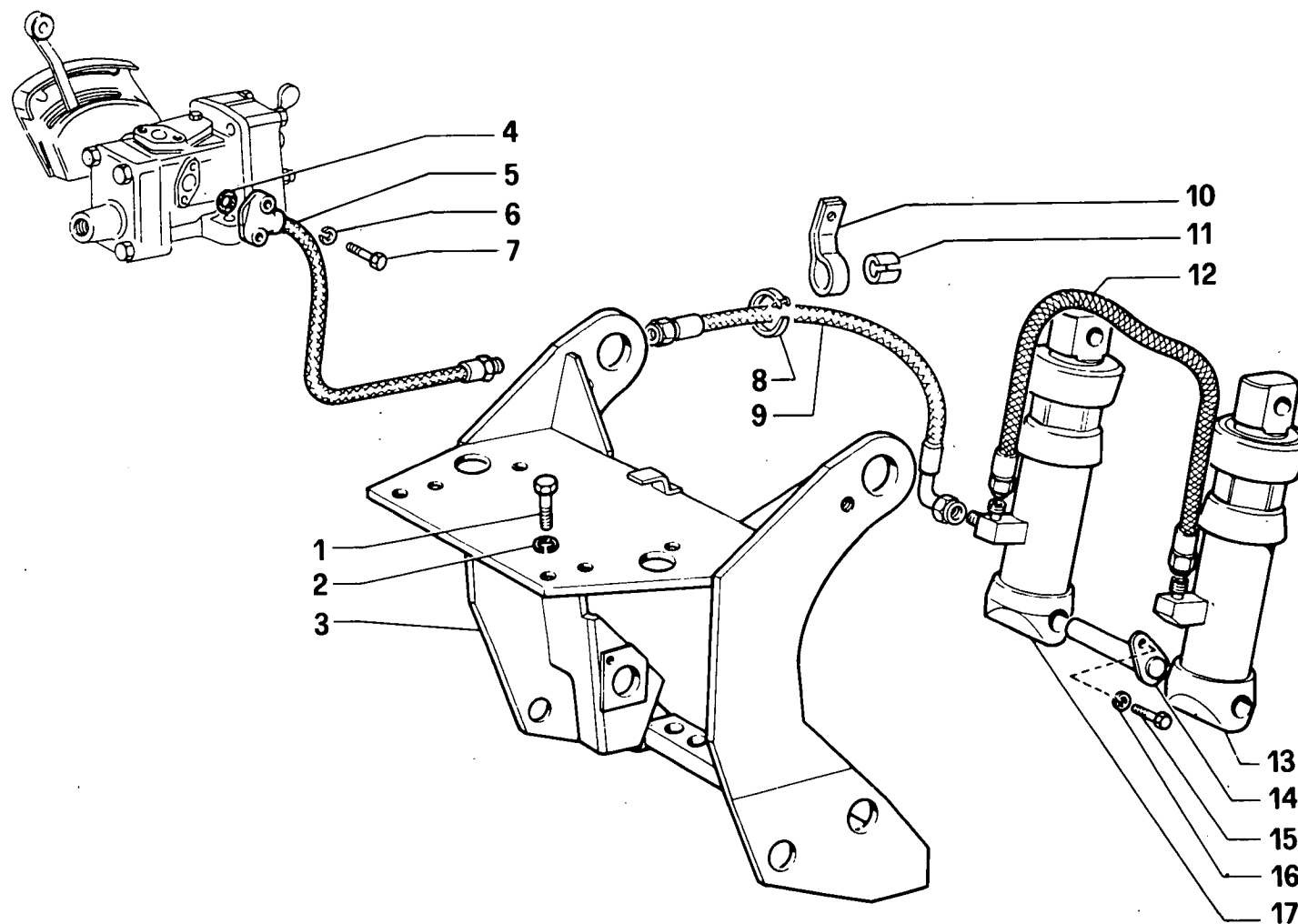

FIG	N. ORDINAZIONE	QTA	DENOMINAZIONE	DESIGNATION	BENENNUNG	DESCRIPTION	DENOMINACIONES
	568162	1	POMPA	POMPE	PUMPE	PUMP	BOMBA
	8281576	1	SERIE GUARNIZIONI	JEU DE JOINTS	DICHTUNGSSATZ	SEALING SET	LOTE JUNTAS
1	8273908	2	ANELLO OR	BAGUE TORIQUE	O-RING	O-SEAL	ANILLO O.
2	8273909	2	GUARNIZIONE	GARNITURE	DICHTUNG	GASKET	JUNTA
3	8273910	2	ANELLO DI TENUTA	JOINT D'ETANCHEITE	DICHTRING	SEAL	JUNTA HERMETICA
4	8273911	1	ANELLO DI SICUREZZA	ARRETOIR	SICHERUNGSRING	LOCKRING	ANILLO DE FRENO
5	8273912	4	BOCCOLA	DOUILLE	BUECHSE	BUSH	CASQUILLO
6	8273913	3	VITE	VIS	SCHRAUBE	SCREW	TORNILLO
7	8273914	1	VITE	VIS	SCHRAUBE	SCREW	TORNILLO
8	8273915	4	DADO	ECROU	MUTTER	NUT	TUERCA
9	8273916	4	ROSETTA DI SICUREZZA	RONDELLE FREIN	SICHERUNGSRING	LOCKWASHER	ARANDELA DE FRENO
10	8273917	4	GUARNIZIONE DI TENUTA	JOINT	DICHTUNG	GASKET	JUNTA
11	8273918	1	LINGUETTA	LINGUET	SCHEIBENFEDER	KEY	CHAVETA
12	8273919	1	DADO	ECROU	MUTTER	NUT	TUERCA
13	8273920	1	ROSETTA DI SICUREZZA	RONDELLE FREIN	SICHERUNGSRING	LOCKWASHER	ARANDELA DE FRENO
14	8273940	2	SUPPORTO	SUPPORT	LAGER	SUPPORT	SOPORTE
15	8274231	1	COPPIA DI INGRANAGGI	COUPLE D'ENGRENAGES	ZAHNRADPAAR	GEAR SET	PAR DE ENGRANAJES
16	8280168	1	DISTANZIALE	ENTRETOISE	ABSTANDSTUECK	SPACER	SEPARADOR
17	8280170	1	FLANGIA	BRIDE	FLANSCH	FLANGE	BRIDA
18	8281201	2	ANELLO	BAGUE	RING	RING	ANILLO
19	8283478	1	COPERCHIO	COUVERCLE	DECKEL	COVER	TAPA

Relevage a cilindres ydrauliques
Hydraulikzylinderkraftheber

Ydraulic cylinder lifter
Elevador cilindros idraulicos



C80/50

SOLLEVATORE A MARTINETTI - 821 -

90.02/04

(09-1981)

FIG	N. ORDINAZIONE	QTA	DENOMINAZIONE	DESIGNATION	BENENNUNG	DESCRIPTION	DENOMINACIONES
1	11408321	6	VITE	VIS	SCHRAUBE	SCREW	TORNILLO
2	10517171	6	ROSETTA DI SICUREZZA	RONDELLE FREIN	SICHERUNGSRING	LOCKWASHER	ARANDELA DE FRENO
3	4956614	1	PIASTRA	PLAQUE	PLATTE	PLATE	PLACA
4	14452980	1	ANELLO OR	BAGUE TORIQUE	O-RING	O-SEAL	ANILLO O.
5	4964332	1	TUBO	TUBE/TUYAU	ROHR	PIPE/TUBE	TUBO
6	10516671	2	ROSETTA DI SICUREZZA	RONDELLE FREIN	SICHERUNGSRING	LOCKWASHER	ARANDELA DE FRENO
7	16043621	2	VITE	VIS	SCHRAUBE	SCREW	TORNILLO
8	10291290	1	ANELLO	BAGUE	RING	RING	ANILLO
9	4953759	1	TUBO FLESSIBILE	TUYAU FLEXIBLE	SCHLAUCH	HOSE	MANGA FLEXIBLE
10	4964330	1	STAFFETTA FISSAGGIO	COLLIER	HALTER	RETAINER	ABRAZADERA
11	4964331	1	DISTANZIALE	ENTRETOISE	ABSTANDSTUECK	SPACER	SEPARADOR
12	4953760	1	TUBO FLESSIBILE	TUYAU FLEXIBLE	SCHLAUCH	HOSE	MANGA FLEXIBLE
13	4956581	1	MARTINETTO SX COMPL.	CYLINDRE A PISTON	KOLBENZYLINDER	CYLINDER	CILINDRO PISTON
14	4956583	2	PERNO	AXE	BULZEN	PIN	EJE
15	15970721	2	VITE	VIS	SCHRAUBE	SCREW	TORNILLO
16	10516871	2	ROSETTA DI SICUREZZA	RONDELLE FREIN	SICHERUNGSRING	LOCKWASHER	ARANDELA DE FRENO
17	4956580	1	MARTINETTO DX COMPL.	CYLINDRE A PISTON	KOLBENZYLINDER	CYLINDER	CILINDRO PISTON

Bras de relevage
Hubarme

Lifter links
Brazos del elevador

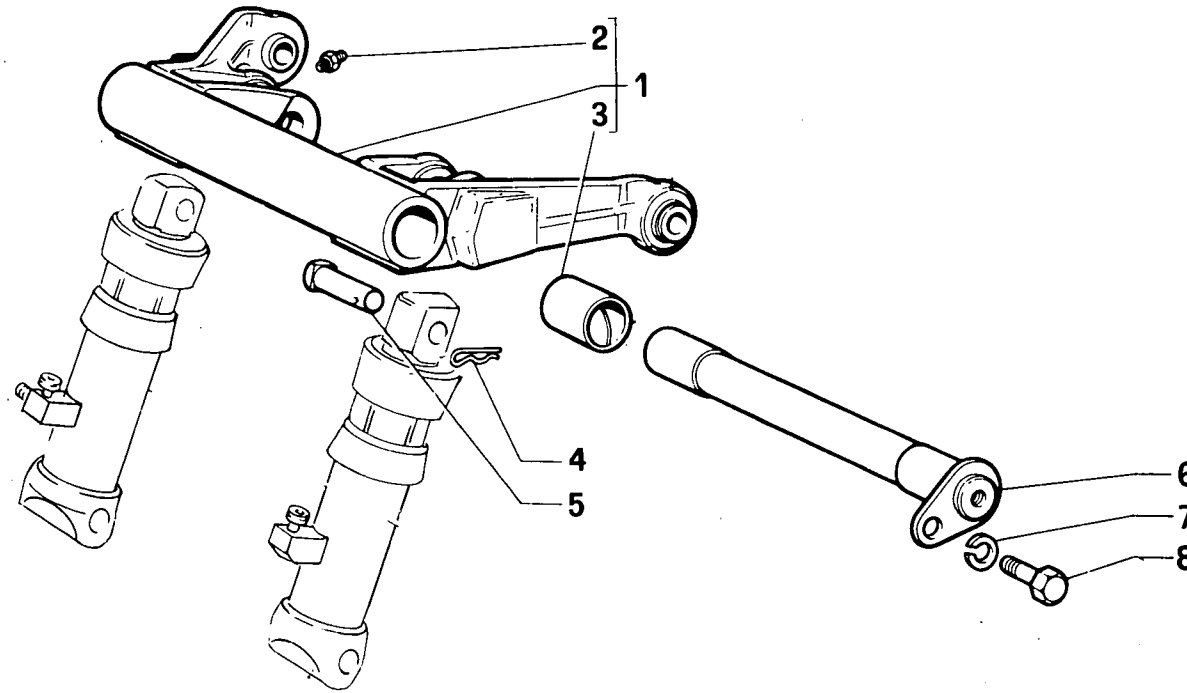

C80/50

BRACCI SOLLEVATORE - 821 -

90.02/05

(09-1981)

FIG	N. ORDINAZIONE	QTA	DENOMINAZIONE	DESIGNATION	BENENNUNG	DESCRIPTION	DENOMINACIONES
1	4956599	1	ALBERO BRACCI	ARBRE	WELLE	SHAFT	ARBOL
2	13407211	1	INGRASSATORE	GRAISSER	SCHMIERNIPPEL	FITTING	ENGRASADOR
3	4953803	2	BOCCOLA	DOUILLE	BUECHSE	BUSH	CASQUILLO
4	567406	2	SPINA	GOUPILLE	STIFT	PIN	PASADOR
5	4956716	2	PERNO	AXE	BOLZEN	PIN	EJE
6	4953766	1	PERNO	AXE	BOLZEN	PIN	EJE
7	10517171	1	ROSETTA DI SICUREZZA	RONDELLE FREIN	SICHERUNGSRING	LOCKWASHER	ARANDELA DE FRENO
8	15836421	1	VITE	VIS	SCHRAUBE	SCREW	TORNILLO

CEB.50

03

MARTINETTO - 821 -

90.2/6

*Cylindre a piston
Kolbenzylinder*

*Cylinder
Cilindro piston*

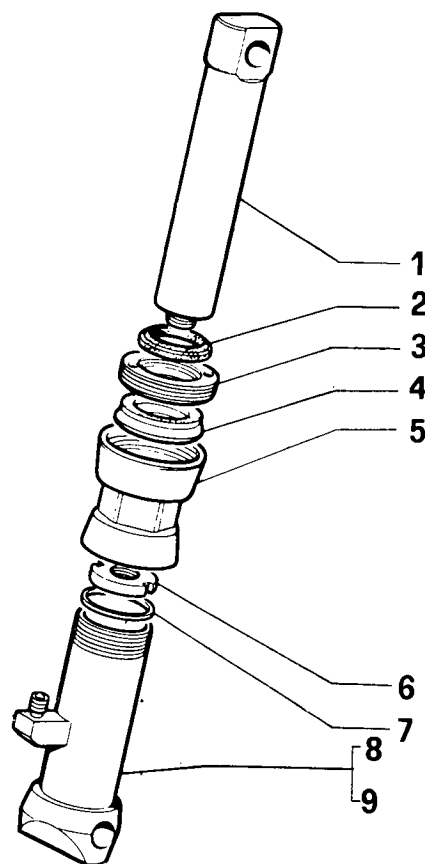

C80/50

MARTINETTO - 821 -

90.02/06

(09-1981)

FIG	N. ORDINAZIONE	QTA	DENOMINAZIONE	DESIGNATION	BENENNUNG	DESCRIPTION	DENOMINACIONES
1	4956589	1	STANTUFFO	PISTON	KOLBEN	PISTON	EMBOLO
2	4956597	1	ANELLO PARAPOLVERE	ANNEAU PARE-POUSS	STAUBRING	DUST RING	ANILLO GUARDAPOLVO
3	4956606	1	GHIERA	VIROLE	GEWINDERING	PLUG	VIROLA
4	4959075	1	GUARNIZIONE	GARNITURE	DICHTUNG	GASKET	JUNTA
5	4956608	1	TESTA CILINDRO	JOINT A ROTULE	STANGENKOPF	HEAD	ARTICULACION
6	4956591	1	GHIERA	VIROLE	GEWINDERING	PLUG	VIROLA
7	4956585	1	GUARNIZIONE	GARNITURE	DICHTUNG	GASKET	JUNTA
8	4956587	1	CORPO MARTINETTO DX	CORPS	GEHAUSE	BODY	CUERPO
9	4956588	1	CORPO MARTINETTO SX	CORPS	GEHAUSE	BODY	CUERPO

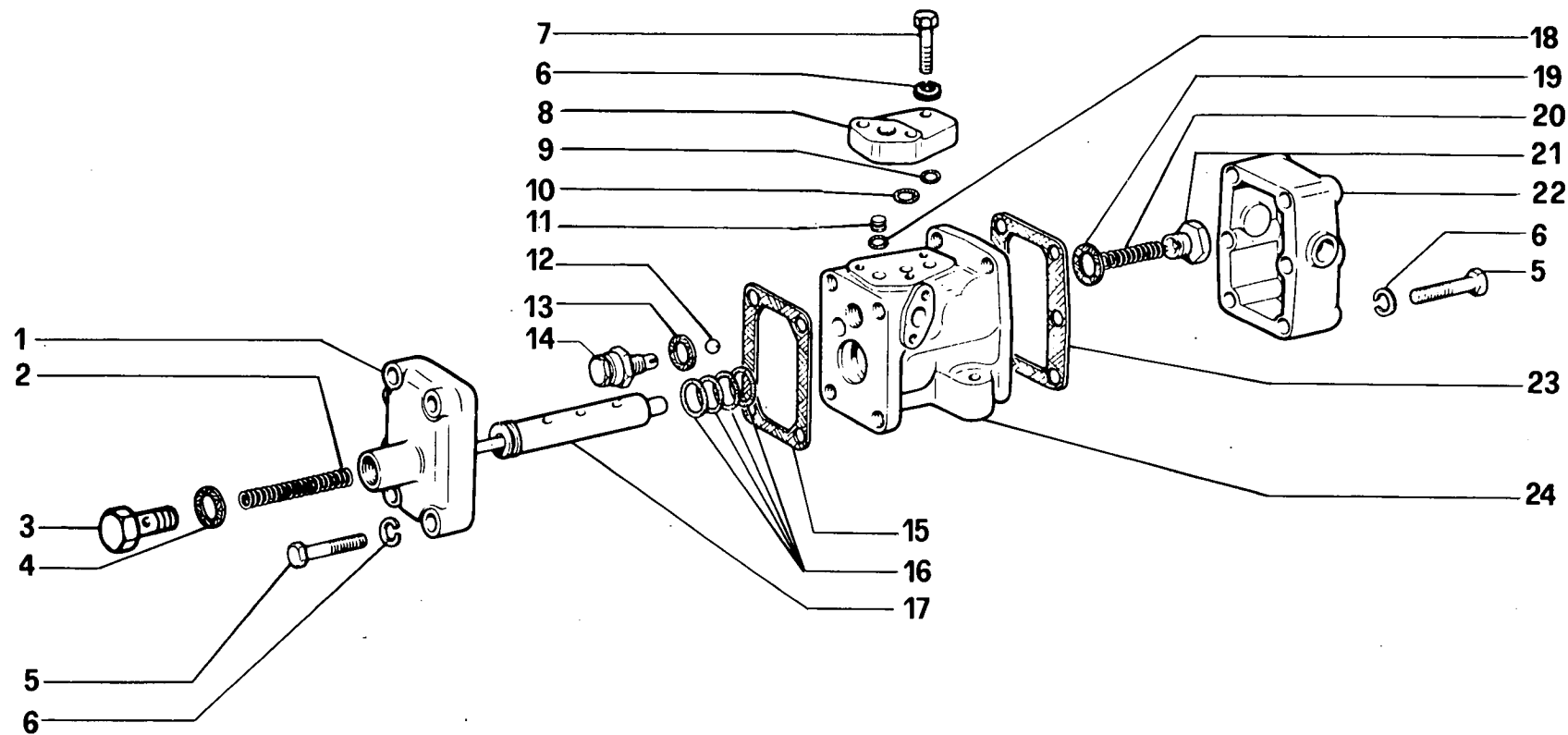

C80/50

DISTRIBUTORE - 821 -

90.02/07

(09-1981)

FIG	N. ORDINAZIONE	QTA	DENOMINAZIONE	DESIGNATION	BENENNUNG	DESCRIPTION	DENOMINACIONES
	4956626	1	DISTRIBUTORE COMPL.	DISTRIBUTEUR	STEUERGERAET	DISTRIBUTOR VALVE	VALVOLA
1	581167	1	COPERCHIO ANT.	COUVERCLE	DECKEL	COVER	TAPA
2	581173	1	MOLLA	RESSORT	FEDER	SPRING	RESORTE
3	4953823	1	RACCORDO	RACCORD	STUTZEN	CONNECTION	RACOR
4	10257060	2	GUARNIZIONE	GARNITURE	DICHTUNG	GASKET	JUNTA
5	16044421	6	VITE	VIS	SCHRAUBE	SCREW	TORNILLO
6	10516671	7	ROSETTA DI SICUREZZA	RONDELLE FREIN	SICHERUNGSRING	LOCKWASHER	ARANDELA DE FRENO
7	16043621	1	VITE	VIS	SCHRAUBE	SCREW	TORNILLO
8	581174	1	FLANGIA	BRIDE	FLANSCH	FLANGE	BRIDA
9	14452980	1	ANELLO OR	BAGUE TORIQUE	O-RING	O-SEAL	ANILLO O.
10	14457280	1	ANELLO OR	BAGUE TORIQUE	O-RING	O-SEAL	ANILLO O.
11	585932	1	TAPPO	BOUCHON	STOPFEN	PLUG	TAPON
12	20063500	1	SFERA	BILLE	KUGEL	BALL	BOLA
13	10263160	1	GUARNIZIONE DI TENUTA	JOINT	DICHTUNG	GASKET	JUNTA
14	4953858	1	VALVOLA LIMITAT. PRESS.	LIMITEUR DE PRESS	DRUCKBEGR. VENTIL	RELIEF VALVE	VAL. LIMIT. PRESION
15	581166	1	GUARNIZIONE	GARNITURE	DICHTUNG	GASKET	JUNTA
16	583198	4	ANELLO OR	BAGUE TORIQUE	O-RING	O-SEAL	ANILLO O.
17	4971982	1	PERNO	AXE	BOLZEN	PIN	EJE
18	14452780	1	GUARNIZIONE	GARNITURE	DICHTUNG	GASKET	JUNTA
19	10278660	1	GUARNIZIONE	GARNITURE	DICHTUNG	GASKET	JUNTA
20	4967333	2	MOLLA	RESSORT	FEDER	SPRING	RESORTE
21	580724	1	TAPPO	BOUCHON	STOPFEN	PLUG	TAPON
22	4953792	1	COPERCHIO	COUVERCLE	DECKEL	COVER	TAPA
23	581168	1	GUARNIZIONE	GARNITURE	DICHTUNG	GASKET	JUNTA
24	585929	1	CORPO DISTRIBUTORE	CORPS	GEHAUSE	BODY	CUERPO

CEO 50

03

COMANDI ESTERNI SOLLEVATORE-821-

*Commandes extérieures de relevage
Äussere Betätigung des Krafthebers*

*Lifter Outer Controls
Mandos exteriores del elevador*

90.2/8

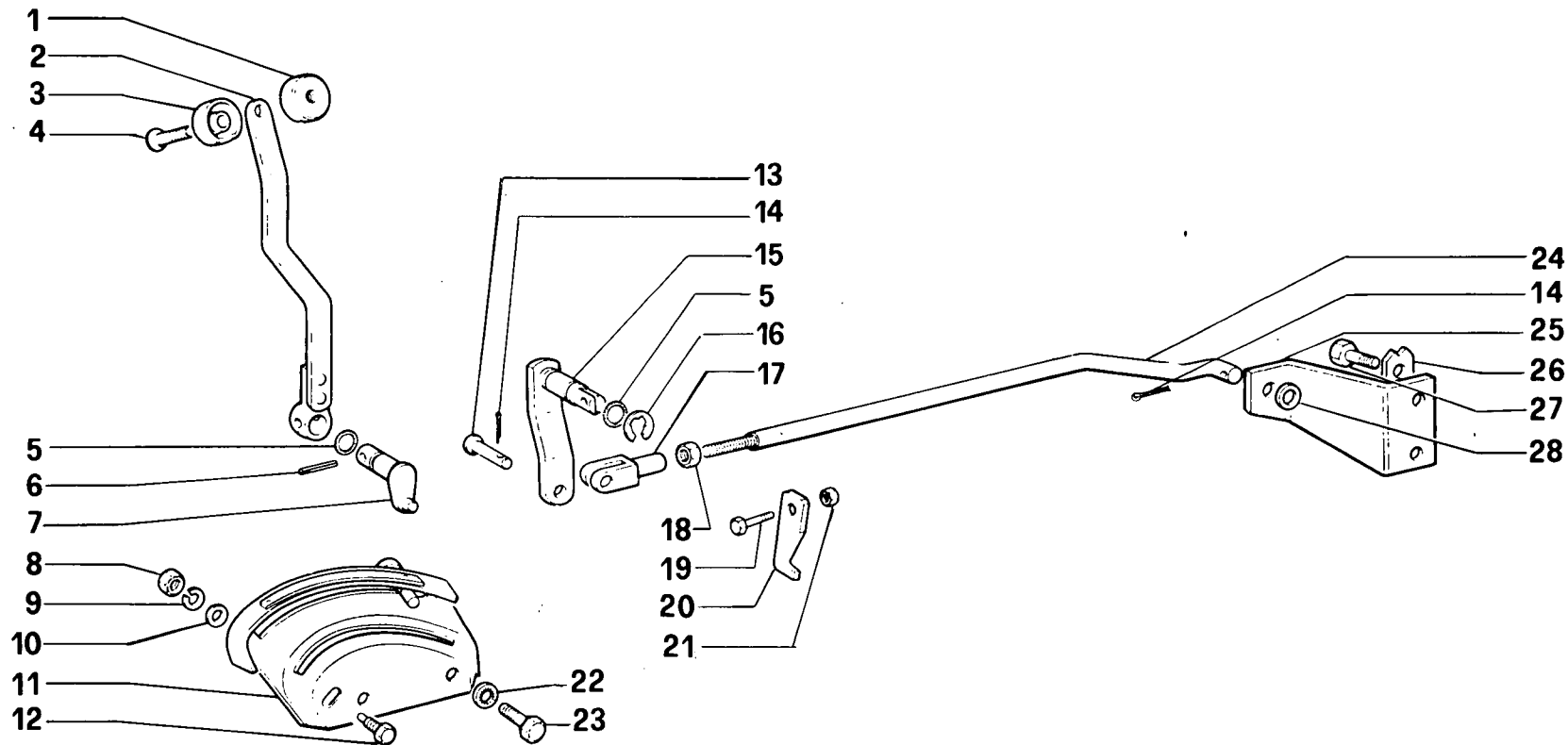
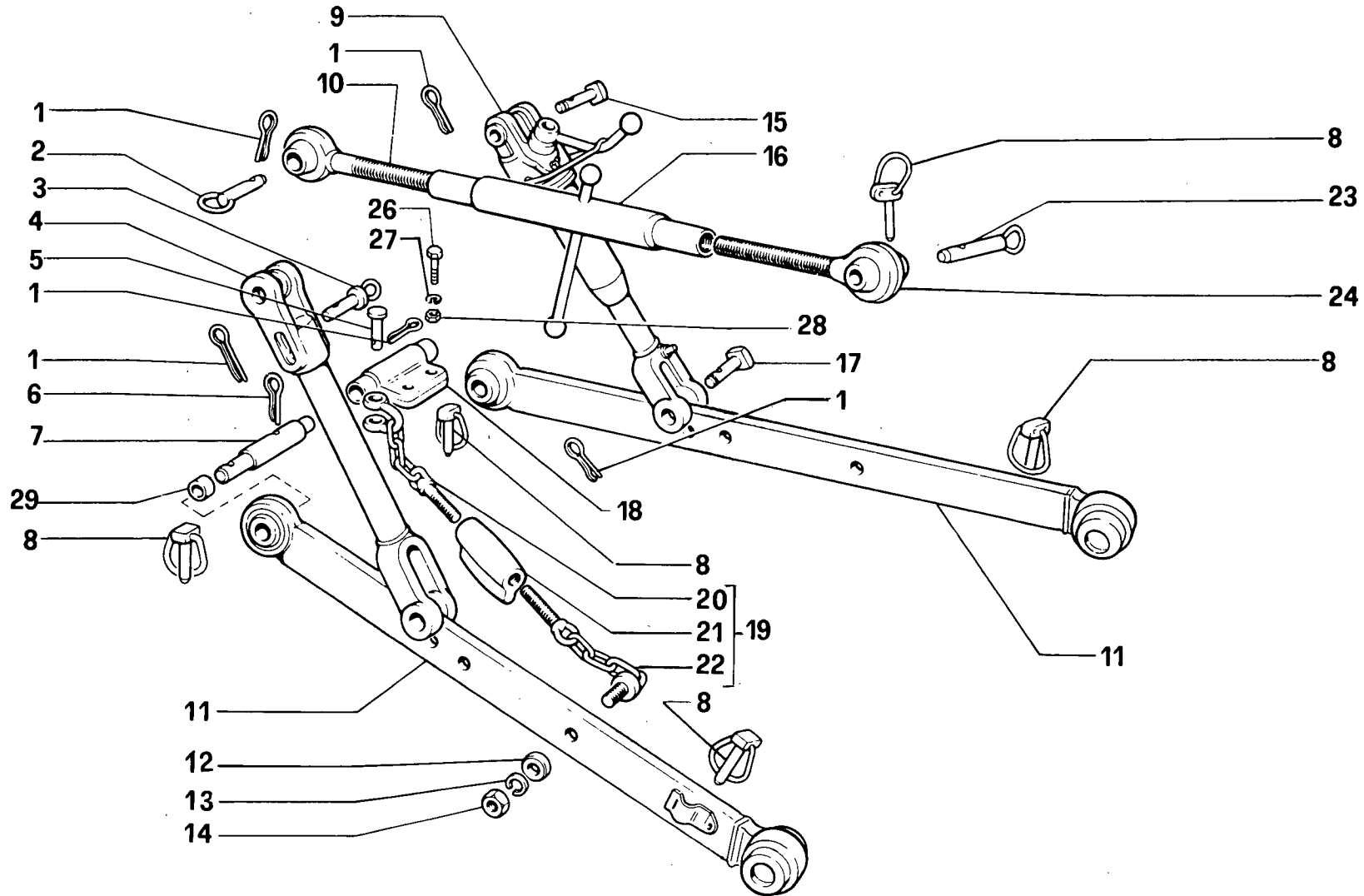

FIG	N. ORDINAZIONE	QTA	DENOMINAZIONE	DESIGNATION	BENENNUNG	DESCRIPTION	DENOMINACIONES
1	581181	1	ESTREMITA° SX	EXTREMITÉ	ENDE	END	EXTREMO
2	581179	1	LEVA	LEVIER	HEBEL	LEVER	PALANCA
3	580284	1	ESTREMITA° DX	EXTREMITÉ	ENDE	END	EXTREMO
4	13301301	1	VITE	VIS	SCHRAUBE	SCREW	TORNILLO
5	14452980	1	ANELLO OR	BAGUE TORIQUE	O-RING	O-SEAL	ANILLO O.
6	14164170	1	SPINA ELASTICA	FICHE A RESSORT	FEDERSTECKER	CLIP PIN	CLAVIJA RESORTE
7	583835	1	PERNO	AXE	BOLZEN	PIN	EJE
8	15896211	1	DADO	ECROU	MUTTER	NUT	TUERCA
9	10516471	1	ROSETTA DI SICUREZZA	RONDELLE FREIN	SICHERUNGSRING	LOCKWASHER	ARANDELA DE FRENO
10	12644401	1	ROSETTA PIANA	RONDELLE	SCHEIBE	WASHER	ARANDELA
11	4956794	1	SETTORE	TIRANT	SPREIZTANGE	STRUT	BIELA
12	581193	1	VITE DI REGISTRO	VIS DE REGLAGE	EINSTELLSCHRAUBE	ADJUSTING SCREW	TORNILLO GRADUACION
13	581197	1	PERNO	AXE	BOLZEN	PIN	EJE
14	10734301	1	COPIGLIA	GOUPILLE	SPLINT	SPLIT PIN	PASADOR ABIERTO
15	581185	1	LEVA	LEVIER	HEBEL	LEVER	PALANCA
16	11088075	1	ANELLO DI SICUREZZA	ARRETOIR	SICHERUNGSRING	LOCKRING	ANILLO DE FRENO
17	581198	1	FORCELLINO	FOURCHE	GABEL	FORK	HORQUILLA
18	10725911	1	DADO	ECROU	MUTTER	NUT	TUERCA
19	581194	1	VITE	VIS	SCHRAUBE	SCREW	TORNILLO
20	4953794	1	LEVA	LEVIER	HEBEL	LEVER	PALANCA
21	12574111	1	DADO	ECROU	MUTTER	NUT	TUERCA
22	12605571	2	ROSETTA DI SICUREZZA	RONDELLE FREIN	SICHERUNGSRING	LOCKWASHER	ARANDELA DE FRENO
23	16043021	2	VITE	VIS	SCHRAUBE	SCREW	TORNILLO
24	4953793	1	PUNTONE	ETA1	STREBE	STRUT	TORNAPUNTA
25	4953677	1	LEVA	LEVIER	HEBEL	LEVER	PALANCA
26	14198810	2	PIASTRINA DI SICUREZZA	PLAQUETTE FREIN	SICHERUNGSBLECH	LOCKPLATE	PLACA DE FRENO
27	15970521	2	VITE	VIS	SCHRAUBE	SCREW	TORNILLO
28	12642701	1	ROSETTA DI SICUREZZA	RONDELLE FREIN	SICHERUNGSRING	LOCKWASHER	ARANDELA DE FRENO

ATTACCO 3 PUNTI

Attacage trois p.ts
Dreipunkt Kupplung

3 point linkage
Acoplam 3 plinktos



C80/50

ATTACCO A 3 PUNTI

90.03/01

(09-1981)

FIG	N. ORDINAZIONE	QTA	DENOMINAZIONE	DESIGNATION	BENENNUNG	DESCRIPTION	DENOMINAZIONES
1	567406	6	SPINA	GOUPILLE	STIFT	PIN	PASADOR
2	579877	1	PERNO (01-02)	AXE	BOLZEN	PIN	EJE
3	822977	1	PERNO	AXE	BOLZEN	PIN	EJE
4	4983311	1	TIRANTE SX	TIRANT	STANGE	ROD	VARILLA
5	568910	2	PERNO	AXE	BOLZEN	PIN	EJE
6	578668	2	COPIGLIA	GOUPILLE	SPLINT	SPLIT PIN	PASADOR ABIERTO
7	5102993	2	PERNO (01-02)	AXE	BOLZEN	PIN	EJE
7	5103002	1	PERNO (03)	AXE	BOLZEN	PIN	EJE
8	4967704	5	SPINA DI SICUREZZA	GOUPILLE	STIFT	PIN	PASADOR
9	4983307	1	TIRANTE REGISTRABILE DX	TIRANT REGLABLE	VERSTELLB. HUBSTREBE	ADJUSTABLE TIEROD	MONTANTE REGULABLE
10	579558	1	PUNTONE ANTERIORE	ETAI	STREBE	STRUT	TORNAPUNTA
11	5103005	2	BRACCIO COMPL.	BRAS	ARM	ARM	BRAZO
12	595050	2	ROSETTA DI SICUREZZA	RONDELLE FREIN	SICHERUNGSRING	LOCKWASHER	ARANDELA DE FRENO
13	10517371	2	ROSETTA DI SICUREZZA	RONDELLE FREIN	SICHERUNGSRING	LOCKWASHER	ARANDELA DE FRENO
14	12164211	2	DADO	ECROU	MUTTER	NUT	TUERCA
15	4989141	2	PERNO SUPERIORE	AXE	BOLZEN	PIN	EJE
16	579562	1	MANICOTTO	MANCHON	MUFFE	SLEEVE	MANGUITO
17	568721	2	PERNO INFERIORE	AXE	BOLZEN	PIN	EJE
18	4951032	1	STAFFA (01-02)	ETRIER	HALTER	BRACKET	SOPORTE
18	4951113	1	STAFFA (03)	ETRIER	HALTER	BRACKET	SOPORTE
19	595174	2	CATENA COMPL.	CHAINE	KETTE	CHIAN	CADENA
20	571441	1	CATENA ANTERIORE	CHAINE	KETTE	CHIAN	CADENA
21	584731	1	MANICOTTO	MANCHON	MUFFE	SLEEVE	MANGUITO
22	595165	1	CATENA POSTERIORE	CHAINE	KETTE	CHIAN	CADENA
23	561831	1	PERNO PUNTONE	AXE	BOLZEN	PIN	EJE
23	822483	1	PERNO	AXE	BOLZEN	PIN	EJE
			PUNTONE - II CATEG.-				
24	579560	1	PUNTONE	ETAI	STREBE	STRUT	TORNAPUNTA
24	4983650	1	PUNTONE	ETAI	STREBE	STRUT	TORNAPUNTA
			POST. - II CATEG. -				
26	11306921	2	VITE (03)	VIS	SCHRAUBE	SCREW	TORNILLO
27	10516871	2	ROSETTA DI SICUREZZA (03)	RONDELLE FREIN	SICHERUNGSRING	LOCKWASHER	ARANDELA DE FRENO
28	12164721	2	DADO (03)	ECROU	MUTTER	NUT	TUERCA
29	570555	2	DISTANZIALE	ENTRETOISE	ABSTANDSTUECK	SPACER	SEPARADOR

CEC.50

01 02 03

TIRANTE REGISTRABILE

Tirant réglable
Verstellbare Hubstrebe

Adjustable Tierod
Montante regulable

90.3/2

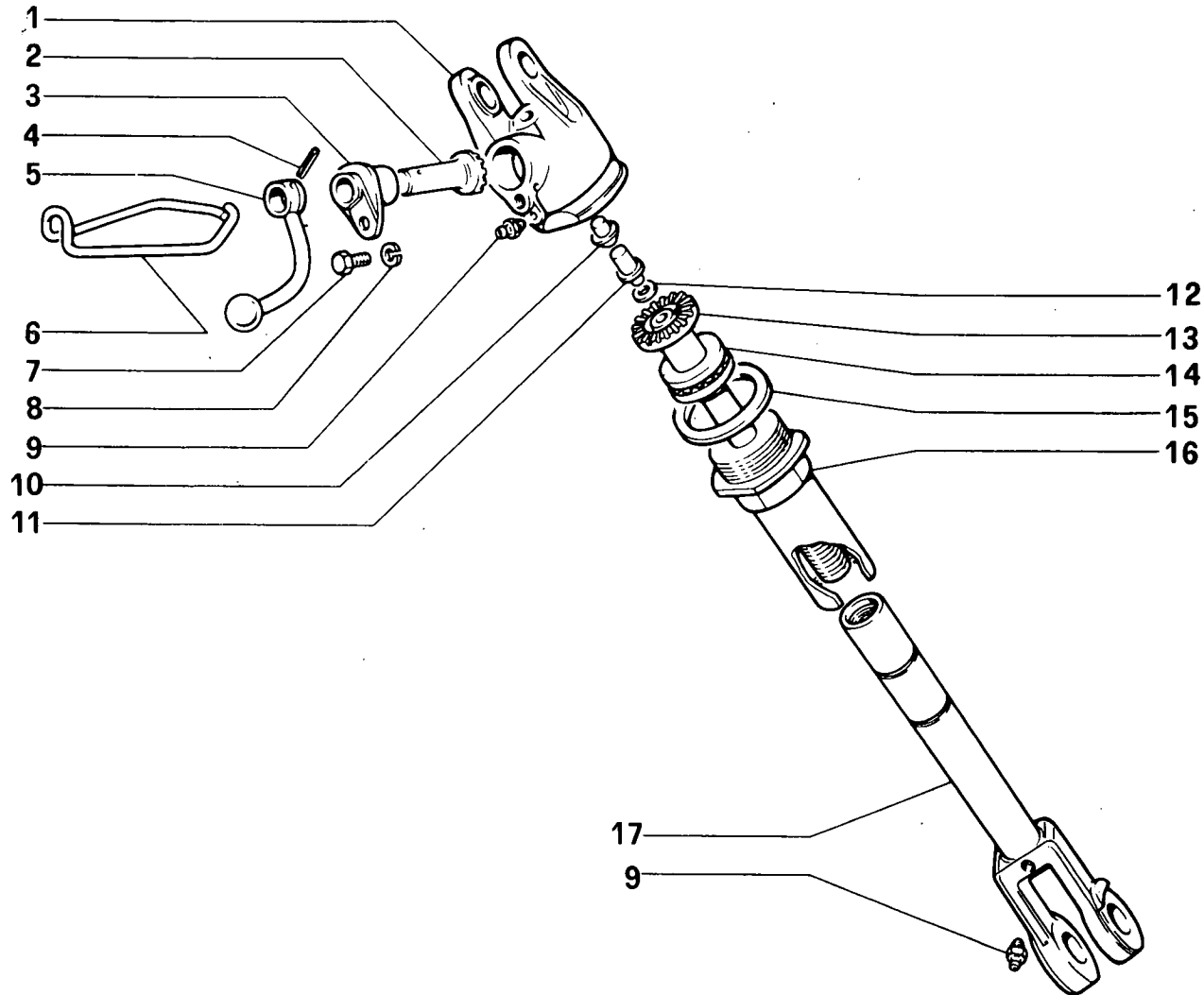

C80/50

TIRANTE REGISTRABILE

90.03/02

(09-1981)

FIG	N. ORDINAZIONE	QTA	DENOMINAZIONE	DESIGNATION	BENENNUNG	DESCRIPTION	DENOMINACIONES
	4983307	1	TIRANTE REGISTRABILE	TIRANT REGLABLE	VERSTELLB. HUBSTREBE	ADJUSTABLE TIEROD	MONTANTE REGULABLE
1	4989136	1	TESTA	JOINT A ROTULE	STANGENKOPF	HEAD	ARTICULACION
2	568716	1	INGRANAGGIO CONDUTTORE	PIGNON CONDUCTEUR	TREIBENDES ZAHNRAD	DRIVING GEAR	PINON CONDUCTOR
3	568719	1	MOZZO	MOYEU	NABE	HUB	FUJE
4	14166170	1	SPINA	GOUPILLE	STIFT	PIN	PASADOR
5	581640	1	MANOVELLA	MANIVELLE	HANDKURBEL	CRANK HANDLE	MANUBRIO/MANIVELA
6	4950756	1	MOLLA	RESSORT	FEDER	SPRING	RESORTE
7	16043421	1	VITE	VIS	SCHRAUBE	SCREW	TORNILLO
8	10516671	1	ROSETTA DI SICUREZZA	RONDELLE FREIN	SICHERUNGSRING	LOCKWASHER	ARANDELA DE FRENO
9	13407211	2	INGRASSATORE	GRAISSER	SCHMIERNIPPEL	FITTING	ENGRASADOR
10	568722	1	PUNTALE	TIGE	DRUCKSTANGE	ROD	VASTAGO
11	568723	1	PUNTALE	TIGE	DRUCKSTANGE	ROD	VASTAGO
12	568725	SN	SPESSORE DI REGISTRO	CALE D'EPaisseur	DISTANZSCHEIBE	SHIM	SUPLEMENTO
13	4964349	1	INGRANAGGIO CONDOTTO	PIGNON CONDUIT	ANGETRIEBENES ZAHNRAD	DRIVEN GEAR	PINON CONDUcido
14	26801280	1	CUSCINETTO REGGISPINTA	PALIER DE BUTEE	DRUCKLAGER	THRUST BEARING	COJ. PRESION/EMPUJE
15	582026	1	ROSETTA DI SICUREZZA	RONDELLE FREIN	SICHERUNGSRING	LOCKWASHER	ARANDELA DE FRENO
16	4964348	1	PROTEZIONE	PROTECTION	ABDECKUNG	SHIELD	DEFENSA
17	4983308	1	TIRANTE INFERIORE	TIRANT	STANGE	ROD	VARILLA

C80.50

01 02

BARRA DI TRAINO

Organe d'attelage
Gerätekupplung

Towing Device
Barra de arrastre

90.4/1

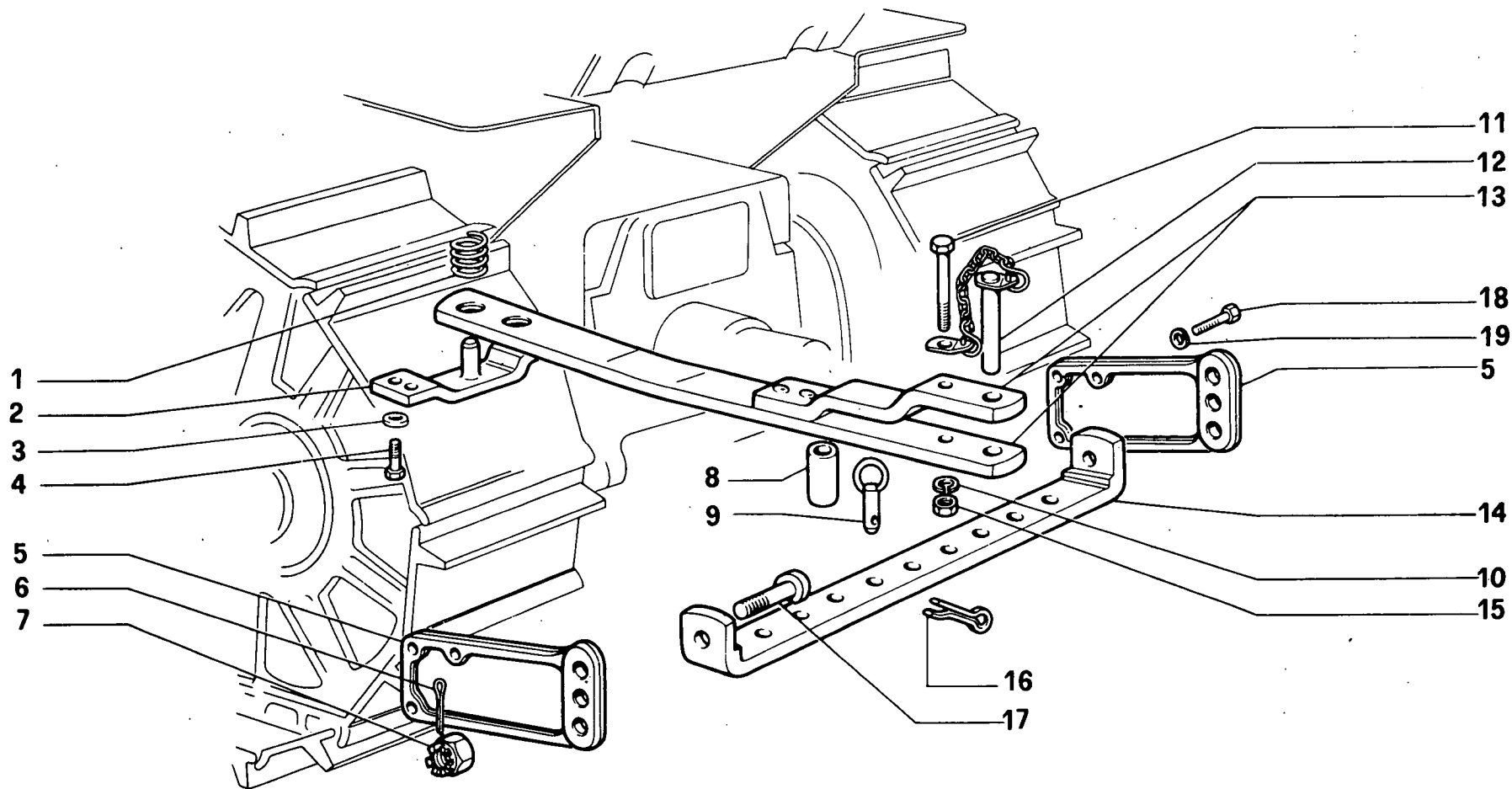

C80/50

BARRA DI TRAINO

90.04/01

(09-1981)

FIG	N. ORDINAZIONE	QTA	DENOMINAZIONE	DESIGNATION	BENENNUNG	DESCRIPTION	DENOMINACIONES
1	4951027	1	MOLLA	RESSORT	FEDER	SPRING	RESORTE
2	4951024	1	STAFFA	ETRIER	HALTER	BRACKET	SOPORTE
3	10517071	4	ROSETTA DI SICUREZZA	RONDELLE FREIN	SICHERUNGSRING	LOCKWASHER	ARANDELA DE FRENO
4	11363021	4	VITE	VIS	SCHRAUBE	SCREW	TORNILLO
5	572372	2	SUPPORTO TRAVERSA	SUPPORT	LAGER	SUPPORT	SOPORTE
6	10733801	2	COPIGLIA	GOUPILLE	SPLINT	SPLIT PIN	PASADOR ABIERTO
7	10724711	2	DADO	ECROU	MUTTER	NUT	TUERCA
8	573209	1	DISTANZIALE	ENTRETOISE	ABSTANDSTUECK	SPACER	SEPARADOR
9	571914	2	PERNO	AXE	BOLZEN	PIN	EJE
10	10517471	3	ROSETTA DI SICUREZZA	RONDELLE FREIN	SICHERUNGSRING	LOCKWASHER	ARANDELA DE FRENO
11	15990121	1	VITE	VIS	SCHRAUBE	SCREW	TORNILLO
12	4951022	1	PERNO	AXE	BOLZEN	PIN	EJE
13	4951021	1	BARRA DI TRAINO	BARRE D'ATTELAGE	ZUGPENDEL	DRAWBAR	LANZA DE REMOLQUE
14	572371	1	TRAVERSA -01-	TRAVERSE	TRAVERSE	CROSSRAIL	TRAVESANO
14	573281	1	TRAVERSA -02-	TRAVERSE	TRAVERSE	CROSSRAIL	TRAVESANO
15	12164311	1	DADO	ECROU	MUTTER	NUT	TUERCA
16	567406	3	SPINA	GOUPILLE	STIFT	PIN	PASADOR
17	573279	2	VITE	VIS	SCHRAUBE	SCREW	TORNILLO
18	4958977	6	VITE	VIS	SCHRAUBE	SCREW	TORNILLO
19	11200171	6	ROSETTA DI SICUREZZA	RONDELLE FREIN	SICHERUNGSRING	LOCKWASHER	ARANDELA DE FRENO

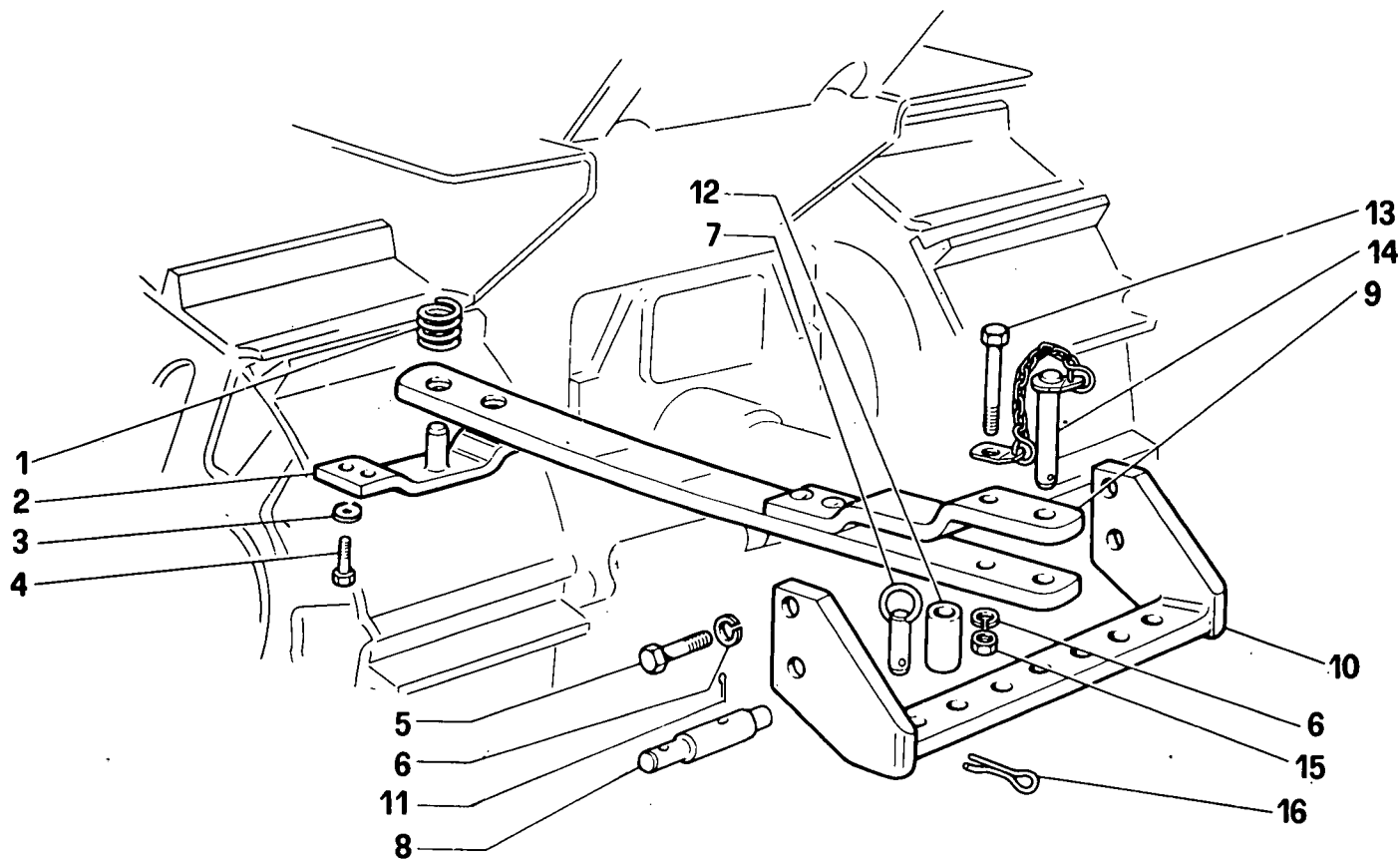

C80/50

BARRA DI TRAINO

90.04/02

(09-1981)

FIG	N. ORDINAZIONE	QTA	DENOMINAZIONE	DESIGNATION	BENENNUNG	DESCRIPTION	DENOMINACIONES
1	4951027	1	MOLLA	RESSORT	FEDER	SPRING	RESORTE
2	4951024	1	STAFFA	ETRIER	HALTER	BRACKET	SOPORTE
3	10517071	4	ROSETTA DI SICUREZZA	RONDELLE FREIN	SICHERUNGSRING	LOCKWASHER	ARANDELA DE FRENO
4	11363021	4	VITE	VIS	SCHRAUBE	SCREW	TORNILLO
5	11408621	4	VITE	VIS	SCHRAUBE	SCREW	TORNILLO
6	10517471	5	ROSETTA DI SICUREZZA	RONDELLE FREIN	SICHERUNGSRING	LOCKWASHER	ARANDELA DE FRENO
7	559917	2	PERNO RITEGNO	AXE	BOLZEN	PIN	EJE
8	4956141	2	PERNO	AXE	BOLZEN	PIN	EJE
9	4951021	1	BARRA DI TRAINO	BARRE D'ATTELAGE	ZUGPENDEL	DRAWBAR	LANZA DE REMOLQUE
10	4951034	1	TRAVERSA	TRAVERSE	TRAVERSE	CROSSRAIL	TRAVESANO
11	578668	2	COPIGLIA	GOUPILLE	SPLINT	SPLIT PIN	PASADOR ABIERTO
12	573209	1	DISTANZIALE	ENTRETOISE	ABSTANDSTUECK	SPACER	SEPARADOR
13	15900121	1	VITE	VIS	SCHRAUBE	SCREW	TORNILLO
14	4951022	1	PERNO COMPL.	AXE	BOLZEN	PIN	EJE
15	12164311	1	DADO	ECROU	MUTTER	NUT	TUERCA
16	567406	1	SPINA	GOUPILLE	STIFT	PIN	PASADOR

CEB 50

01 02 03

DISTRIBUTORE DOPPIO EFFETTO

Distributeur a double effet
Doppeltwirkenden steuerschieber

Double effect distributor valve
Distribudor de doble efecto

90.5/1

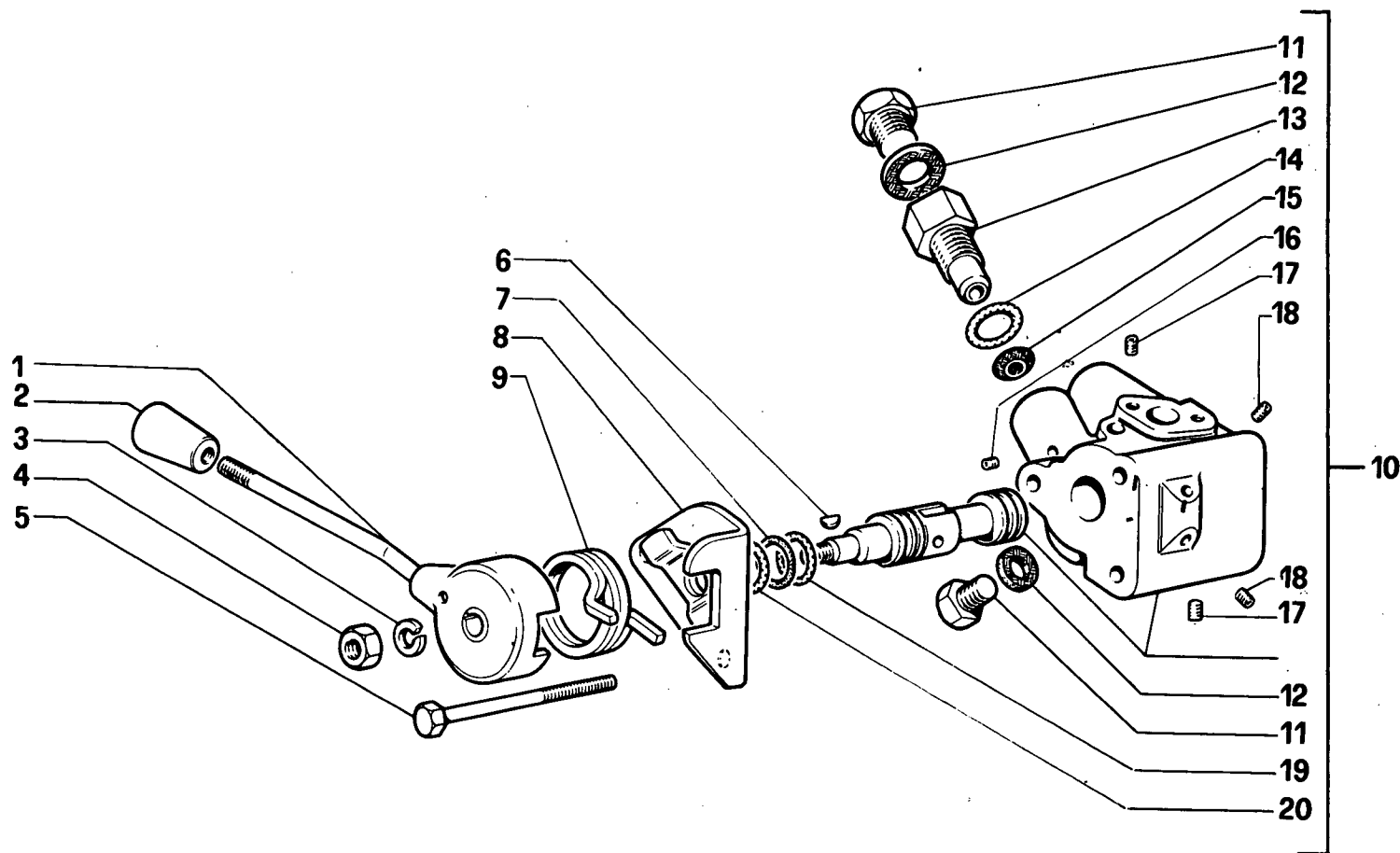

C80/50

DISTRIBUTORE DOPPIO EFFETTO

90.05/01

(09-1981)

FIG	N. ORDINAZIONE	QTA	DENOMINAZIONE	DESIGNATION	BENENNUNG	DESCRIPTION	DENOMINACIONES
	588769	1	DISTRIBUTORE COMPL.	DISTRIBUTEUR	STEUERGERAET	DISTRIBUTOR VALVE	VALVULA
1	594632	1	LEVA COMPL.	LEVIER	HEBEL	LEVER	PALANCA
2	561880	1	IMPUGNATURA	POIGNEE	GRIF	KNOB	BOTON
3	10516871	1	ROSETTA DI SICUREZZA	RONDELLE FREIN	.SICHERUNGSRING	LOCKWASHER	ARANDELA DE FRENO
4	10791011	1	DADO	ECROU	MUTTER	NUT	TUERCA
5	15971721	3	VITE	VIS	SCHRAUBE	SCREW	TORNILLO
6	10205710	1	LINGUETTA	LINGUET	SCHEIBENFEDER	KEY	CHAVETA
7	14463880	1	ANELLO OR	BAGUE TORIQUE	O-RING	O-SEAL	ANILLO O.
8	588773	1	COPERCHIO	COUVERCLE	DECKEL	COVER	TAPA
9	588779	1	MOLLA	RESSORT	FEDER	SPRING	RESORTE
10	4998886	1	CORPO COMPL.	CORPS	GEHAUSE	BODY	CUERPO
11	10300711	2	TAPPO	BOUCHON	STOPFEN	PLUG	TAPON
12	10278660	2	GUARNIZIONE	GARNITURE	DICHTUNG	GASKET	JUNTA
13	576233	1	RACCORDO	RACCORD	STUTZEN	CONNECTION	RACOR
14	14457080	1	ANELLO OR	BAGUE TORIQUE	O-RING	O-SEAL	ANILLO O.
15	10260060	1	GUARNIZIONE	GARNITURE	DICHTUNG	GASKET	JUNTA
16	4998655	1	TAPPO	BOUCHON	STOPFEN	PLUG	TAPON
17	14324901	2	TAPPO	BOUCHON	STOPFEN	PLUG	TAPON
18	4998656	2	TAPPO	BOUCHON	STOPFEN	PLUG	TAPON
19	14462880	1	ANELLO OR	BAGUE TORIQUE	O-RING	O-SEAL	ANILLO O.
20	4998888	1	ANELLO ANTIESTRUSIONE	BAGUE ANTI EXTRUSION	ANTIEXSTRUSIONSRING	ANTIEXSTRUSION RING	ANILLO ANTE EXSTRUSION

C80.50

01 02 03

DISTRIBUTORE DOPPIO EFFETTO

Distributeur a double effet
Doppeltwirkenden steuerschieber

Double effect distributor valve
Distribudor de doble efecto

90.5/2

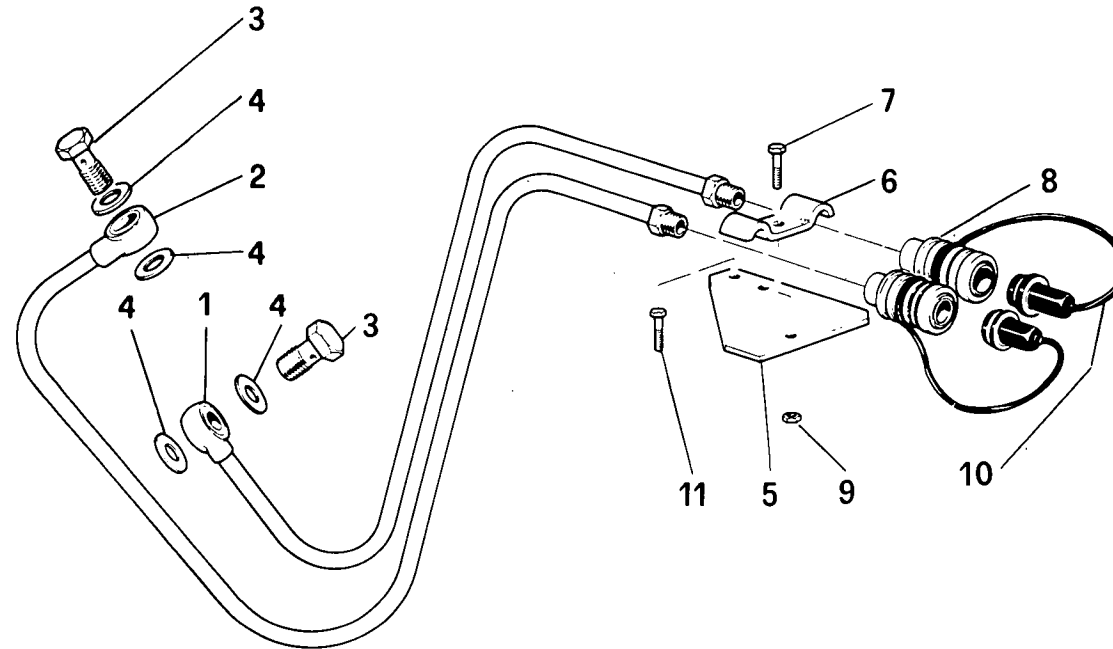

C80/50

DISTRIBUTORE DOPPIO EFFETTO

90.05/02

(09-1981)

FIG	N. ORDINAZIONE	QTA	DENOMINAZIONE	DESIGNATION	BENENNUNG	DESCRIPTION	DENOMINACIONES
1	4991597	1	TUBO SUPERIORE	TUBE/TUYAU	ROHR	PIPE/TUBE	TUBO
2	4991598	1	TUBO INFERIORE	TUBE/TUYAU	ROHR	PIPE/TUBE	TUBO
3	10184417	2	BOCCHETTONE	VIS-RACCORD	HOLHLSCHRAUBE	UNION	BOQUILLA
4	10257060	2	GUARNIZIONE	GARNITURE	DICHTUNG	GASKET	JUNTA
5	4991599	1	PIASTRA	PLAQUE	PLATTE	PLATE	PLACA
6	587898	1	STAFFA	ETRIER	HALTER	BRACKET	SOPORTE
7	15970721	1	VITE	VIS	SCHRAUBE	SCREW	TORNILLO
8	5104083	2	GIUNTO RAPIDO	ACCOUPLMENT	KUPPLUNG	COUPLING	ARRASTRE
9	12164711	1	DADO	ECROU	MUTTER	NUT	TUERCA
10	44981005	2	TAPPO	BOUCHON	STOPFEN	PLUG	TAPON
11	15973821	2	VITE	VIS	SCHRAUBE	SCREW	TORNILLO

CEO.50

01 02 03

CASSETTA

*Coffres
Ablegefächer*

*Boxes and Receptacles
Cajones*

91.1/1

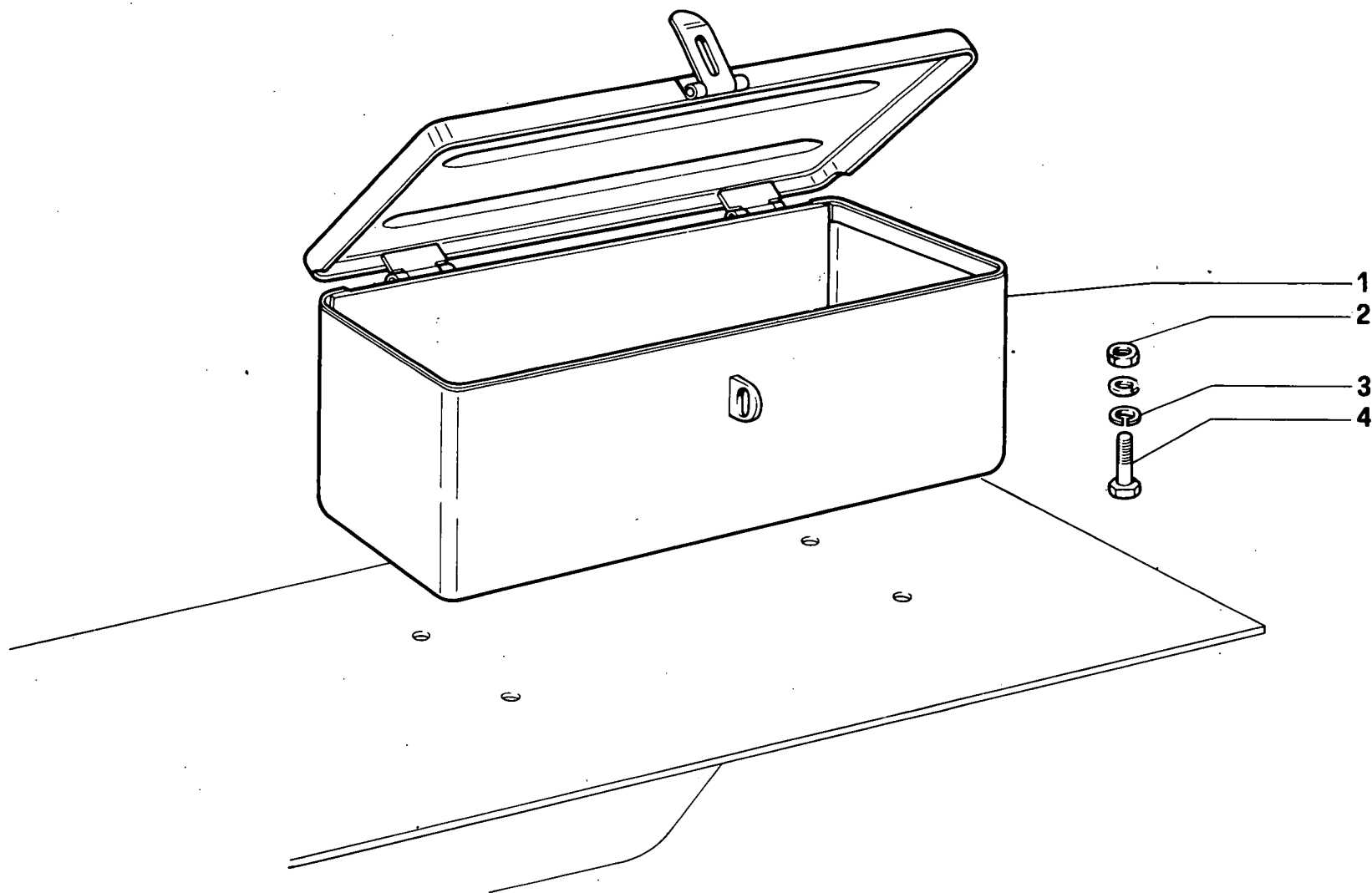

C80/50

CASSETTA PER ATTREZZI

91.01/01

(09-1981)

FIG	N. ORDINAZIONE	QTA	DENOMINAZIONE	DESIGNATION	BENENNUNG	DESCRIPTION	DENOMINACIONES
1	4989839	1	CASSETTA PER ATTREZZI	COFFRE A OUTILS	KASTEN FUER WERKZEUGE	TOOL BOX	CAJA DE HERRAMIENTAS
2	12164711	4	DADO	ECROU	MUTTER	NUT	TUERCA
3	10516871	4	ROSETTA DI SICUREZZA	RONDELLE FREIN	SICHERUNGSRING	LOCKWASHER	ARANDELA DE FRENO
4	11306921	4	VITE	VIS	SCHRAUBE	SCREW	TORNILLO

C80.50

01 02 03

Outillage
Werkzeugausrüstung

DOTAZIONE ATTREZZI

Toolkit
Equipo herramientas

91.1/2

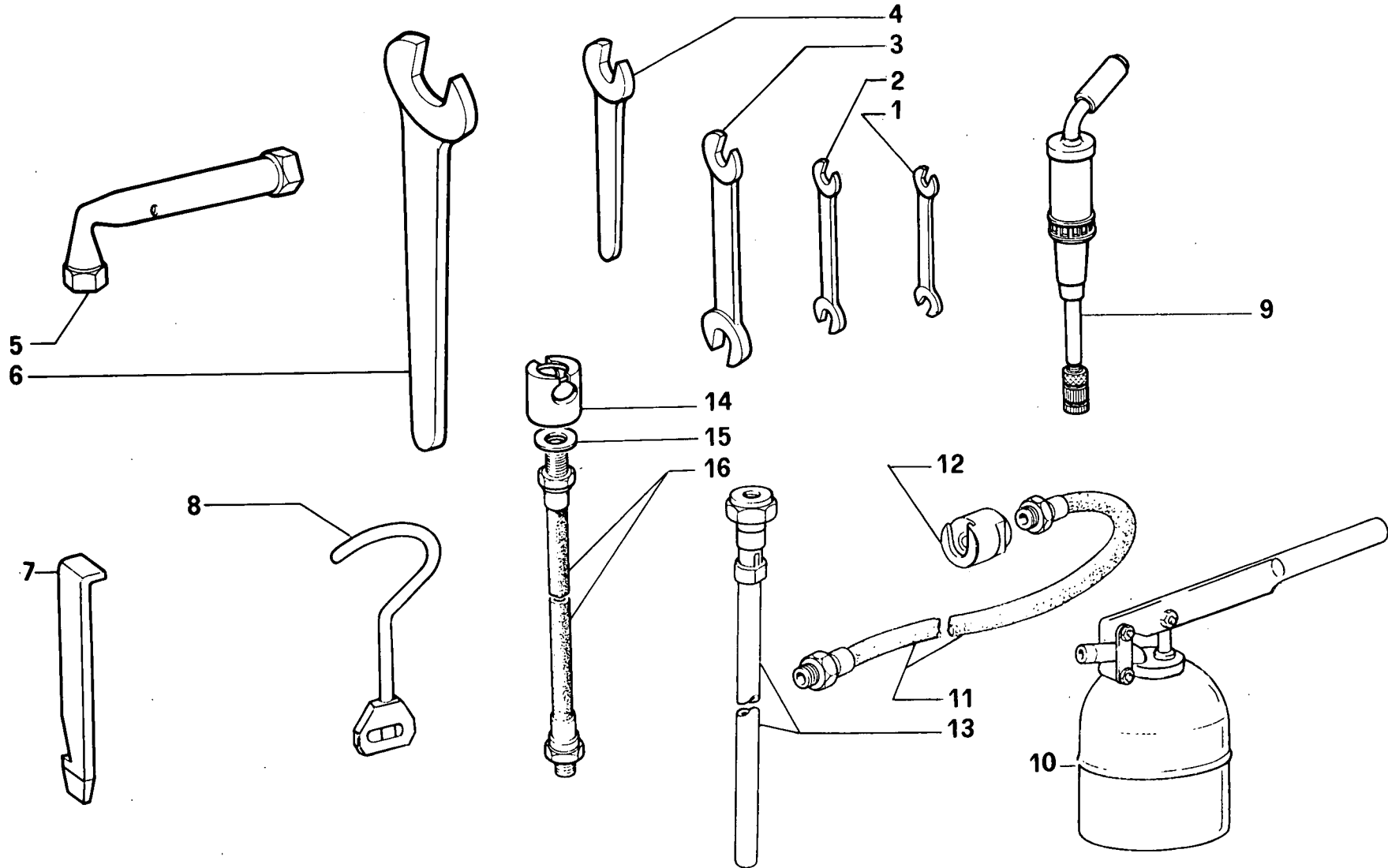

C80/50

DOTAZIONE ATTREZZI

91.01/02

(09-1981)

FIG	N. ORDINAZIONE	QTA	DENOMINAZIONE	DESIGNATION	BENENNUNG	DESCRIPTION	DENOMINACIONES
	4960158	1	BORSA PER UTENSILI	TROUSSE PORTE-OUTILS	TASCHE F.WERKZEUGE	TOOL BAG	BOLSA PARA UTILES
1	14583371	1	CHIAVE 10-13	CLE	SCHLUESSEL	WRENCH	LLAVE
2	14583471	1	CHIAVE 11-14	CLE	SCHLUESSEL	WRENCH	LLAVE
3	14580771	1	CHIAVE 17-19	CLE	SCHLUESSEL	WRENCH	LLAVE
4	14585471	1	CHIAVE 22	CLE	SCHLUESSEL	WRENCH	LLAVE
5	14584431	1	CHIAVE 22 A TUBO	CLE	SCHLUESSEL	WRENCH	LLAVE
6	14586071	1	CHIAVE 50	CLE	SCHLUESSEL	WRENCH	LLAVE
7	569842	1	LEVA	LEVIER	HEBEL	LEVER	PALANCA
			REGISTRO FRIZIONE				
8	539062	1	MANIGLIA	POIGNEE	GRIFF	HANDLE	MANECILLA
9	4967255	1	POMPA	POMPE	PUMPE	PUMP	BOMBA
10	4981746	1	POMPA	POMPE	PUMPE	PUMP	BOMBA
11	4983237	1	TUBO FLESSIBILE	TUYAU FLEXIBLE	SCHLAUCH	HOSE	MANGA FLEXIBLE
12	4980622	1	TESTA COMPL.	JOINT A ROTULE	STANGENKOPF	HEAD	ARTICULACION
13	5103446	1	TUBO LUBRIFICAZIONE	TUBE/TUYAU	ROHR	PIPE/TUBE	TUBO
14	549537	1	TESTA COMPL.	JOINT A ROTULE	STANGENKOPF	HEAD	ARTICULACION
15	10287380	2	GUARNIZIONE	GARNITURE	DICHTUNG	GASKET	JUNTA
16	555486	1	TUBO FLESSIBILE	TUYAU FLEXIBLE	SCHLAUCH	HOSE	MANGA FLEXIBLE

C80.50

01 02 03

COMANDO FRENO RIMORCHIO

Commande de frein de remorque
Anhängerbremse

Trailer Brake Control
Freno del remolque

91.1/3

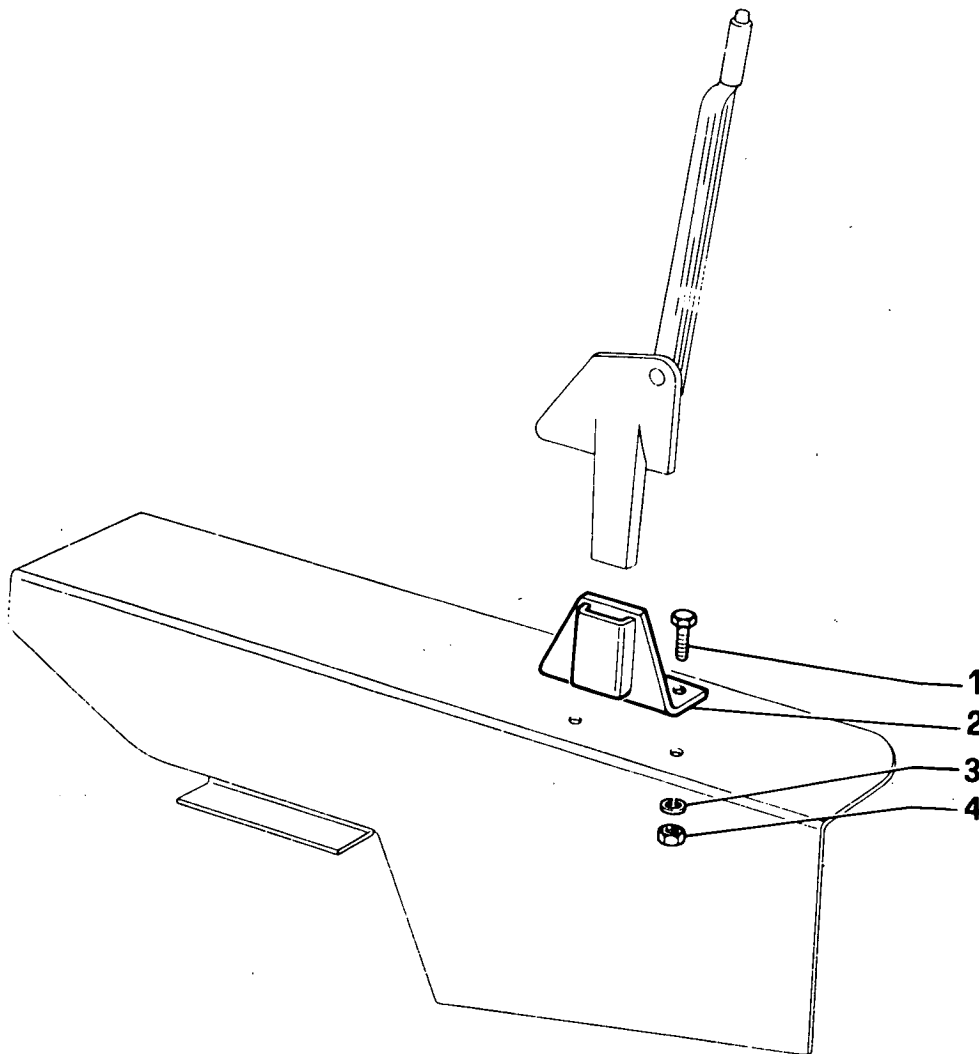

C80/50

SUPPORTO LEVA FRENO RIMORCHIO

91.01/03

(09-1981)

FIG	N. ORDINAZIONE	QTA	DENOMINAZIONE	DESIGNATION	BENENNUNG	DESCRIPTION	DENOMINACIONES
1	11306921	2	VITE	VIS	SCHRAUBE	SCREW	TORNILLO
2	5110181	1	SUPPORTO LEVA	SUPPORT	LAGER	SUPPORT	SOPORTE
3	10516870	2	ROSETTA DI SICUREZZA	RONDELLE FREIN	SICHERUNGSRING	LOCKWASHER	ARANDELA DE FRENO
4	12164711	2	DADO	ECROU	MUTTER	NUT	TUERCA

MODIFICHE

**MODIFICATIONS
ÄNDERUNGEN**

**MODIFICATIONS
MODIFICACIONES**

	M o d i f i c a	Sgr. Interessati e Norme di Ricambio